

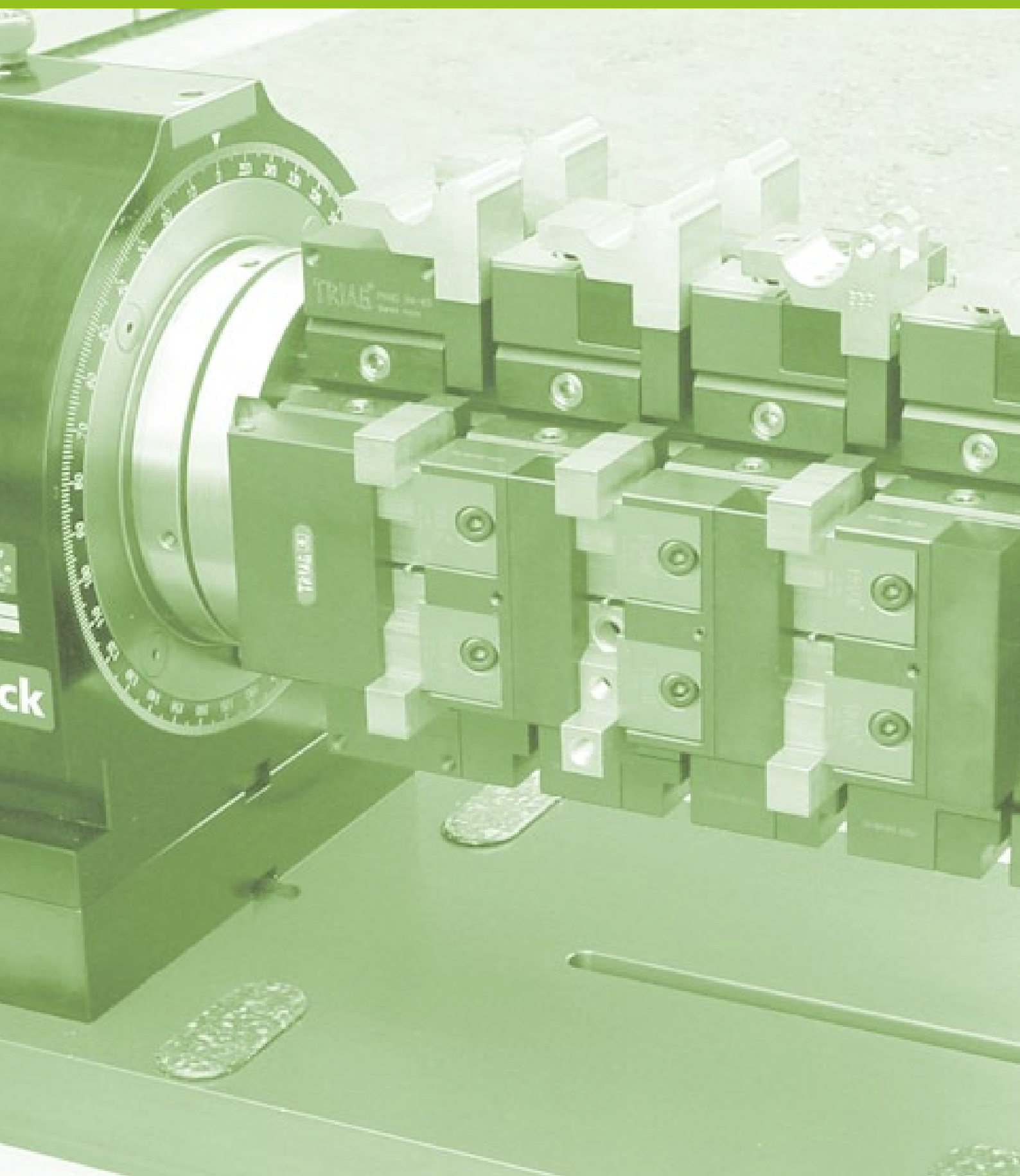

*power*CLAMP & *5axes power*CLAMP





1 tripoxyMINERAL mit unterschiedlichen Werkstücken bestückt
 tripoxyMINERAL tombstones holding a variety of workpieces
 tripoxyMINERAL garni avec des pièces différentes à usiner

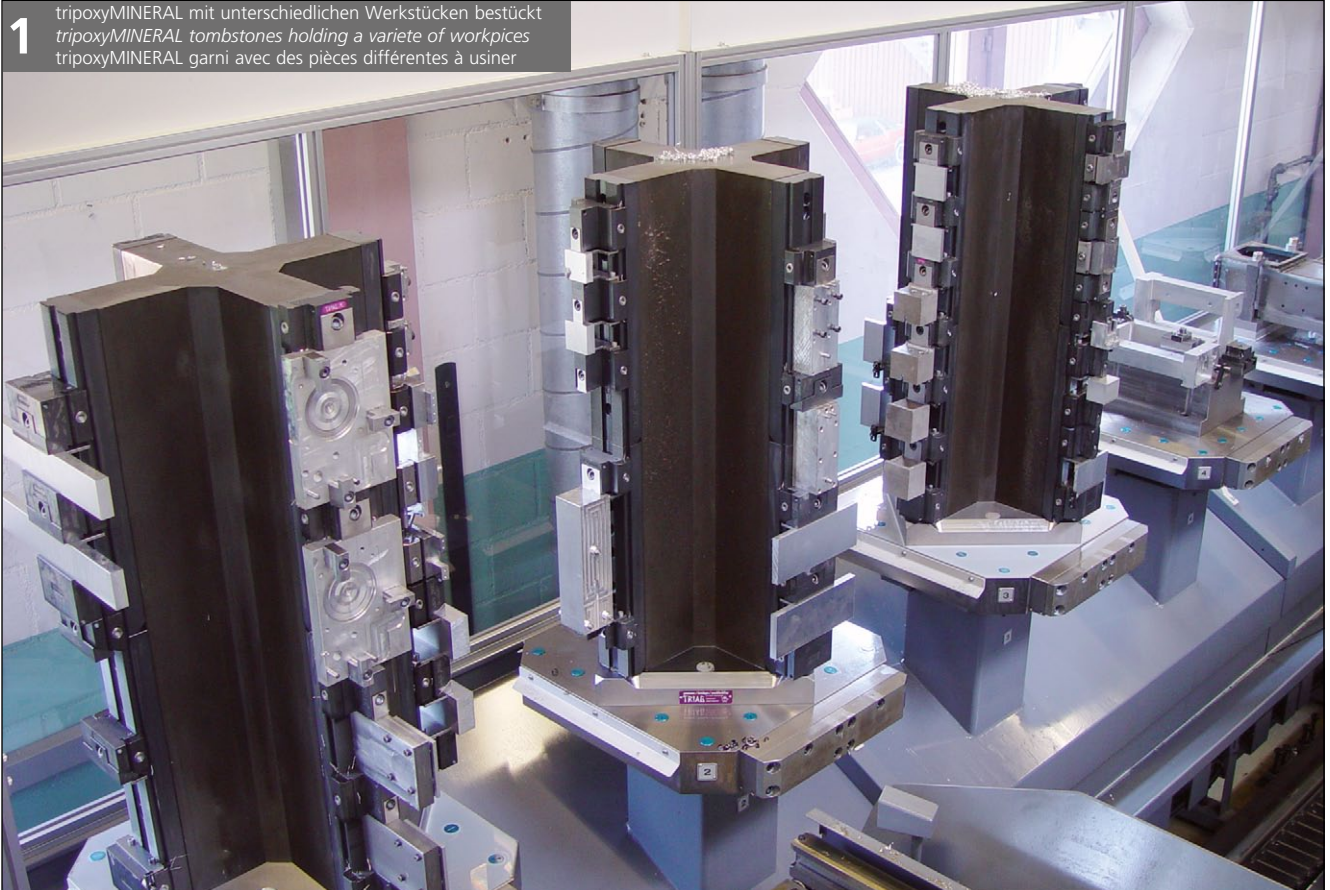

3 Zentrischspanner auf einem Spezialturm
 Centric vices installed on a special tombstone
 Module de serrage à centrer sur une tourelle spéciale

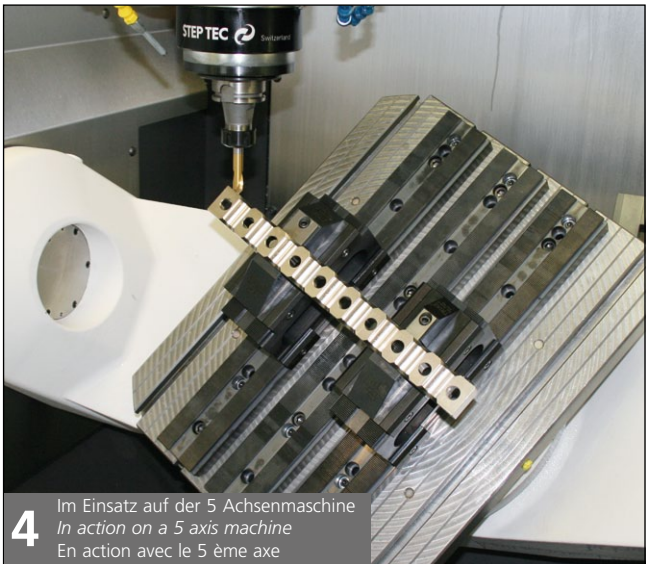
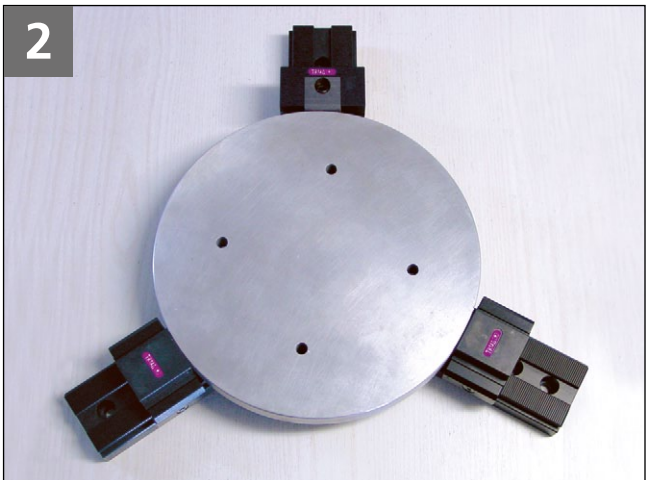

Im Einsatz auf der 5 Achsenmaschine
 In action on a 5 axis machine
 En action avec le 5^{ème} axe

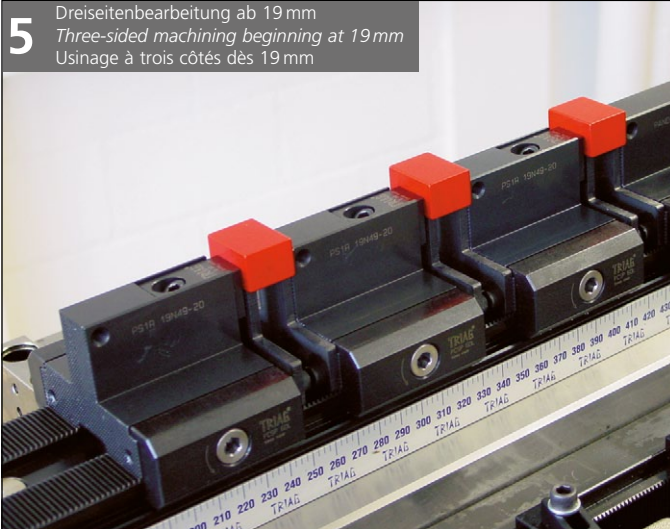

5 Dreiseitenbearbeitung ab 19 mm
 Three-sided machining beginning at 19 mm
 Usinage à trois côtés dès 19 mm



6 Das Triag Power Clamp im Einsatz als Spannstock (Starterset)
 Triag Power Clamp in action as machine vise (starter set)
 Le Triag Power Clamp en action comme étau (starter set)



7 Aufspannung mit Power Clamp auf einem „Triproxy“ Mineralgussturm
 Set up with Power Clamp on a tombstone made of composite concrete
 Serrage Power Clamp sur une tourelle à minérale coulée



8 Toolclick mit Power Clamp
 Toolclick with Power Clamp
 Toolclick avec Power Clamp



9 ...im Einsatz auf der 4. Achse
 ...in action on the 4th axis
 ...en action avec le 4ème axe



10 ...im Einsatz auf der 5 Achsenmaschine
 ...in action on a 5 axis machine
 ...en action avec le 5 ème axe

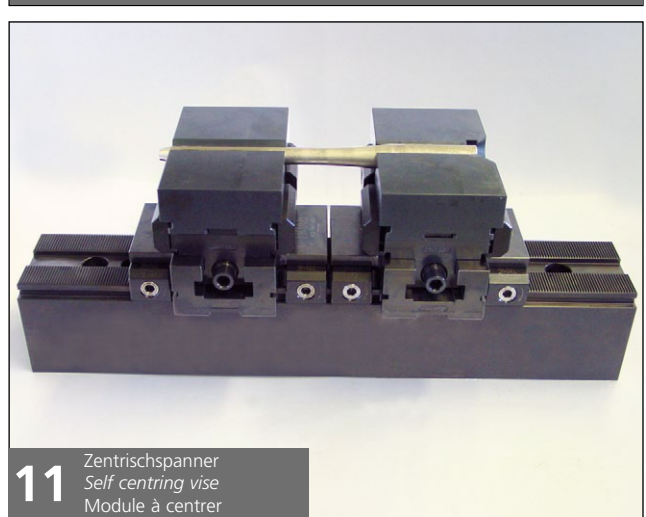

11 Zentrischspanner
 Self centring vise
 Module à centrer

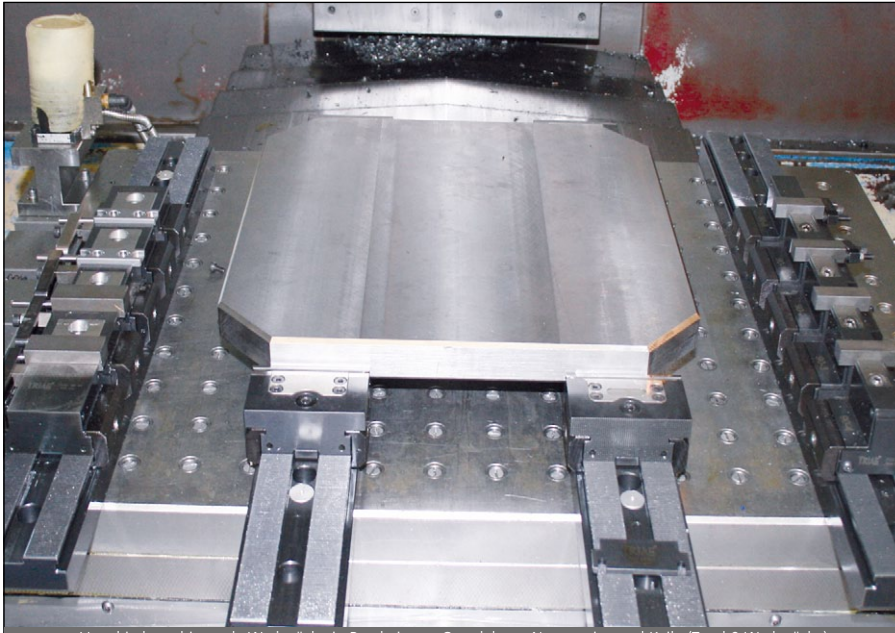

12 Verschiedene dringende Werkstücke in Bearbeitung, Grundplatte, Nutensteine und Keile (Total 9 Werkstücke)
Various urgent work pieces in progress, base plate, nuts and wedges (totally 9 pieces)
 Diverses pièces de travaux urgents en cours, la plaque de base, les noix et les cales (total 9 pièces)

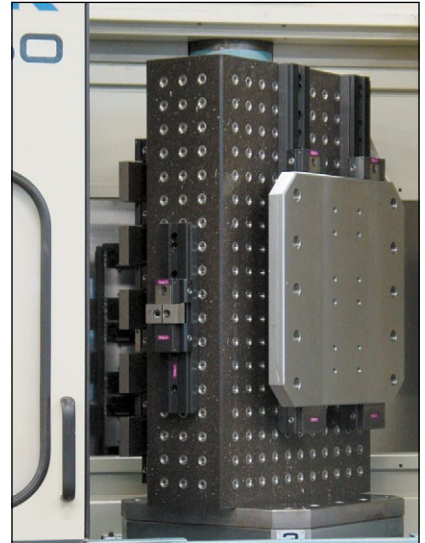

13 Einzelspannung einer grossen Platte auf «tripoxy» Mineralgussturm
Single set up of a large plate on tombstone made of composite concrete
 Serrage simple d'une grande plaquette sur une tourelle à minérale coulée

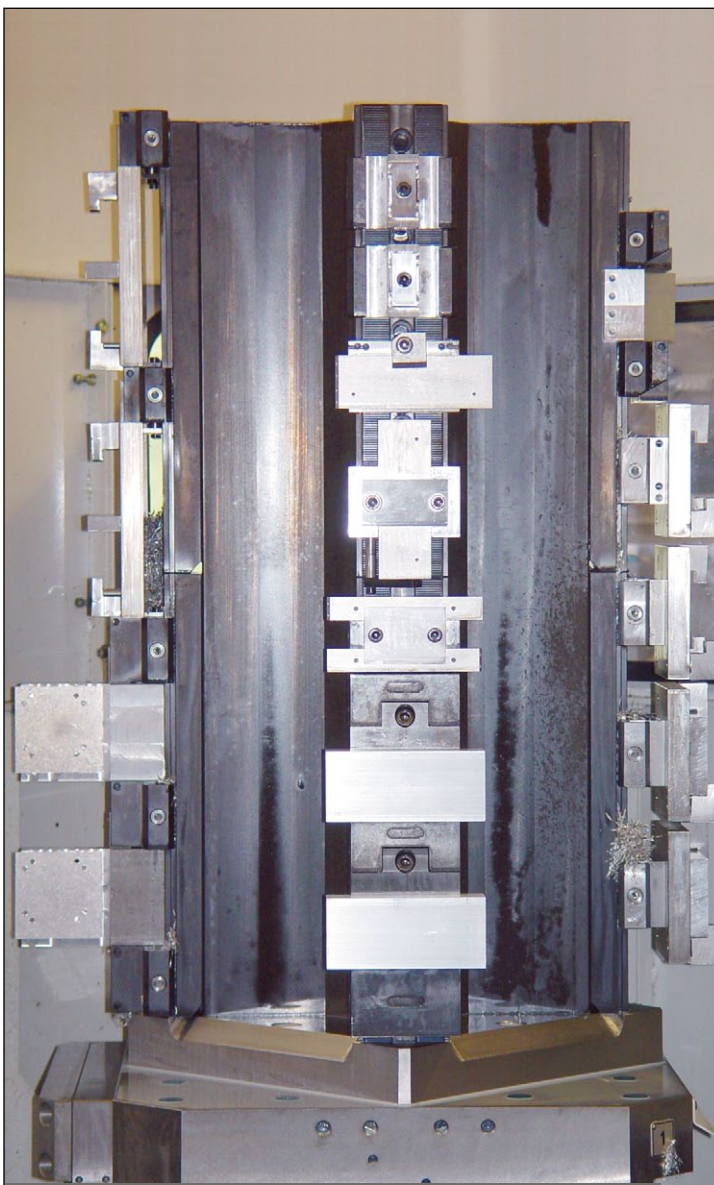

15 Spezifische Fixierung unterschiedlicher Werkstücke mit Power Clamp
Dedicated fixturing of various workpieces on Power Clamp
 Fixation spécifique de pièces à usiner différentes du système Power Clamp

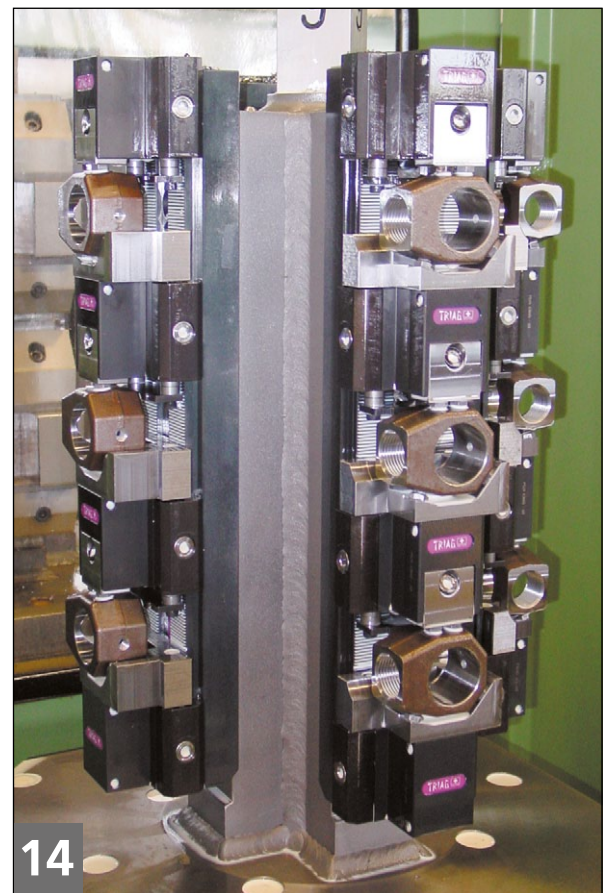

14

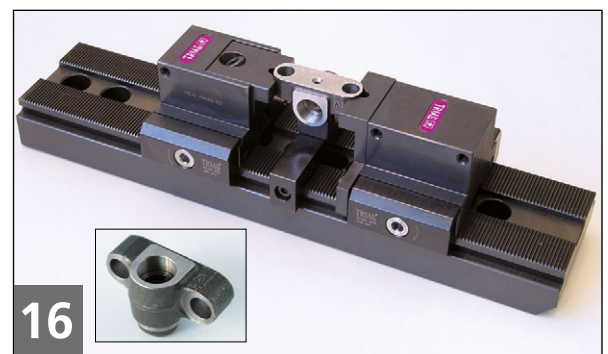

16

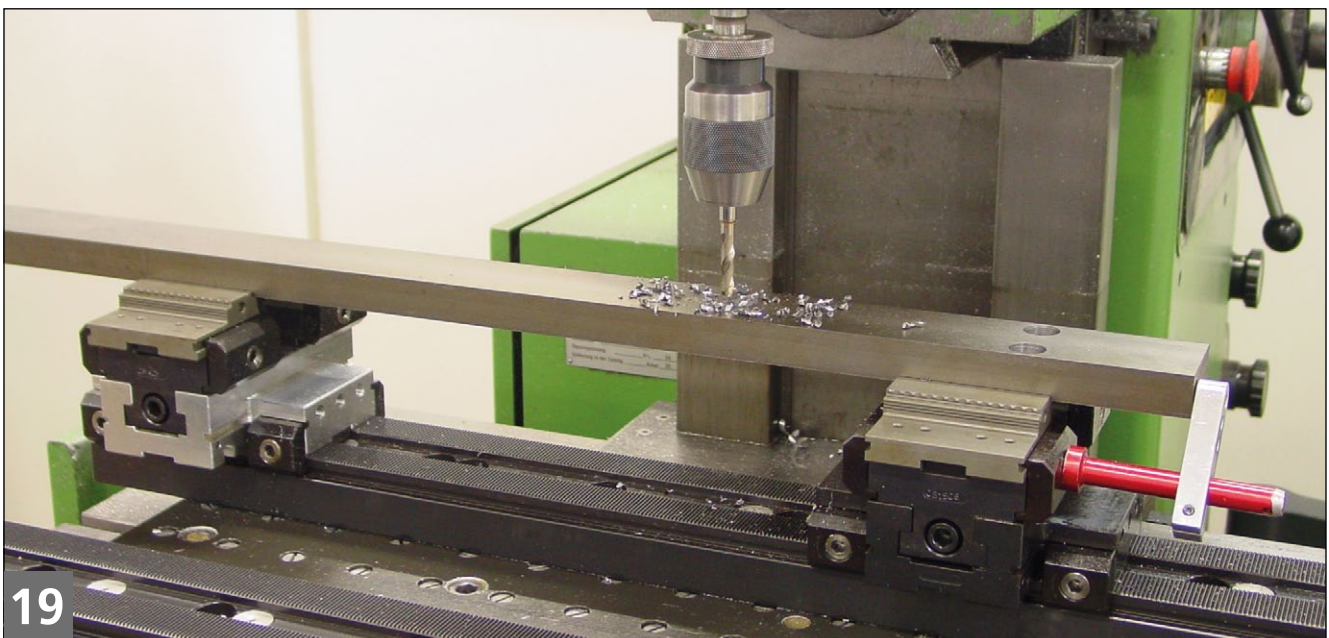
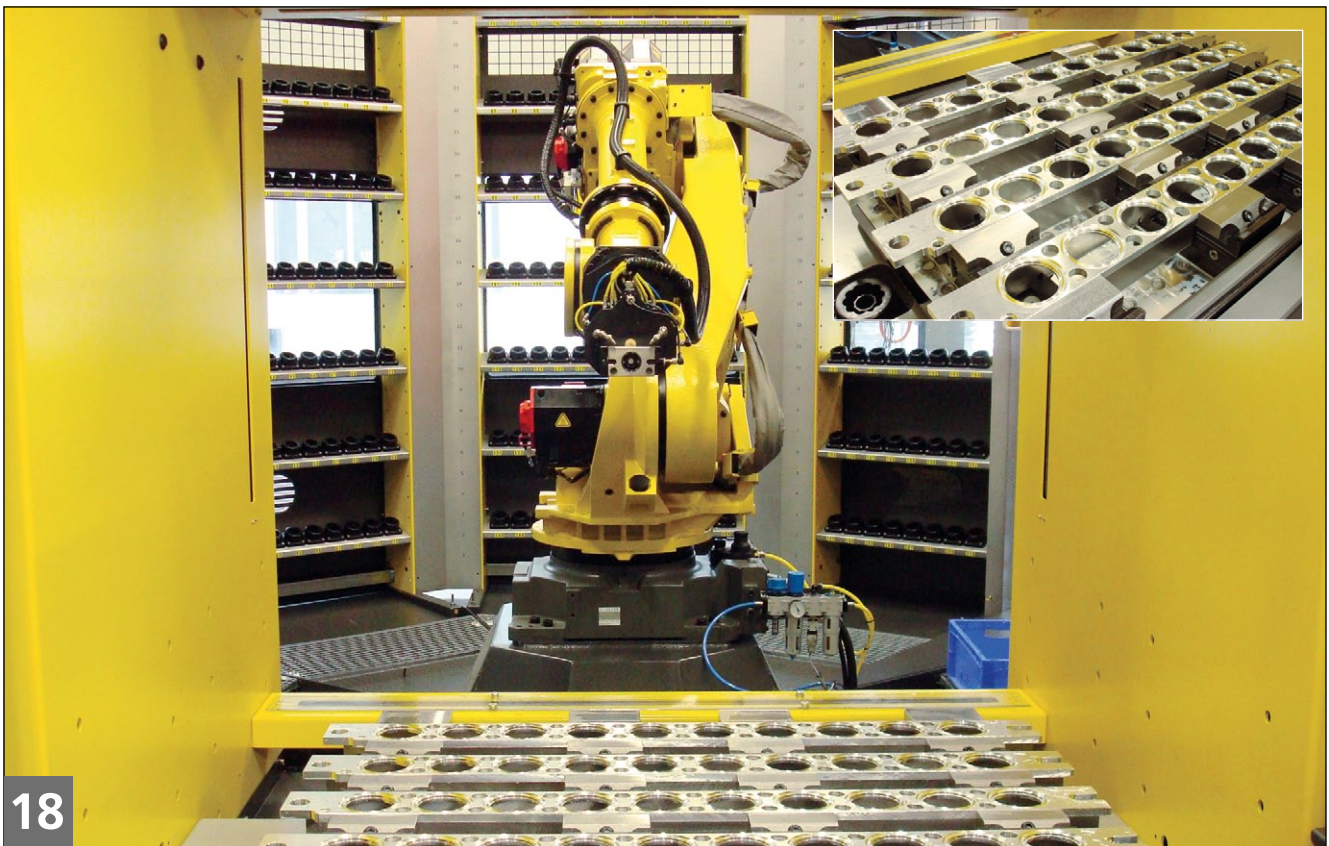
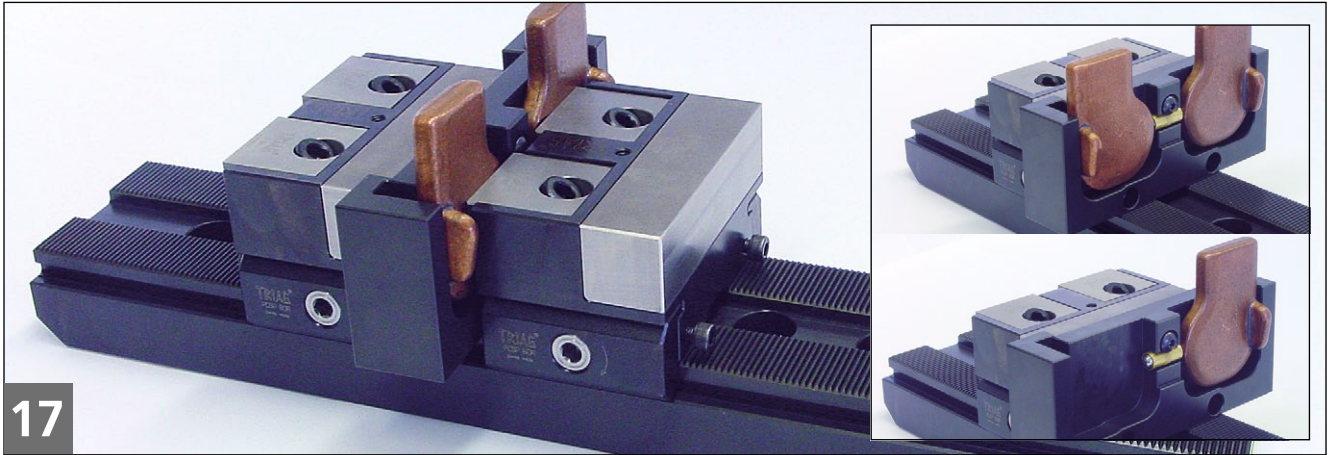

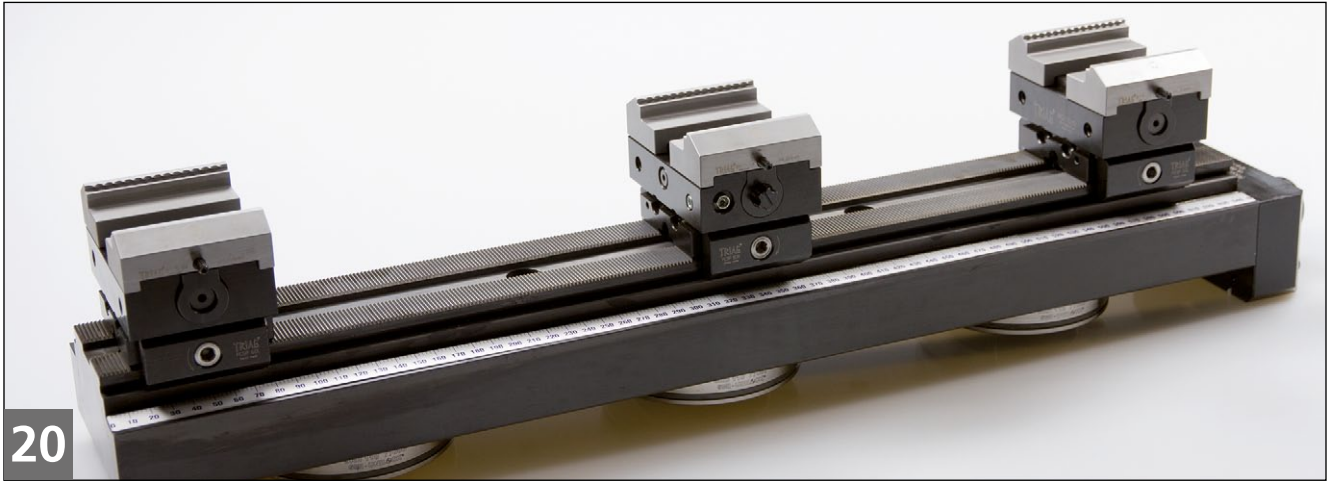

20

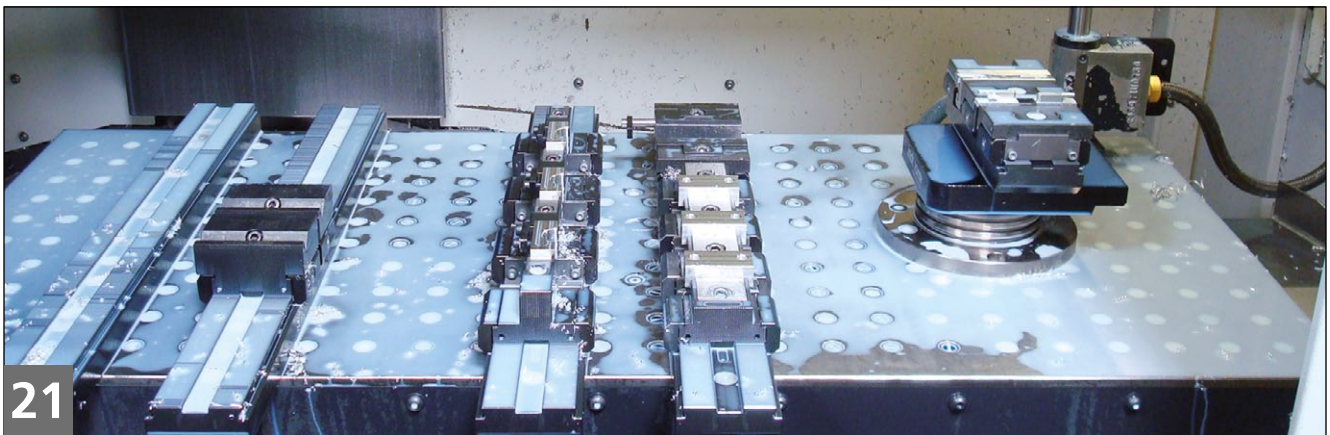

21

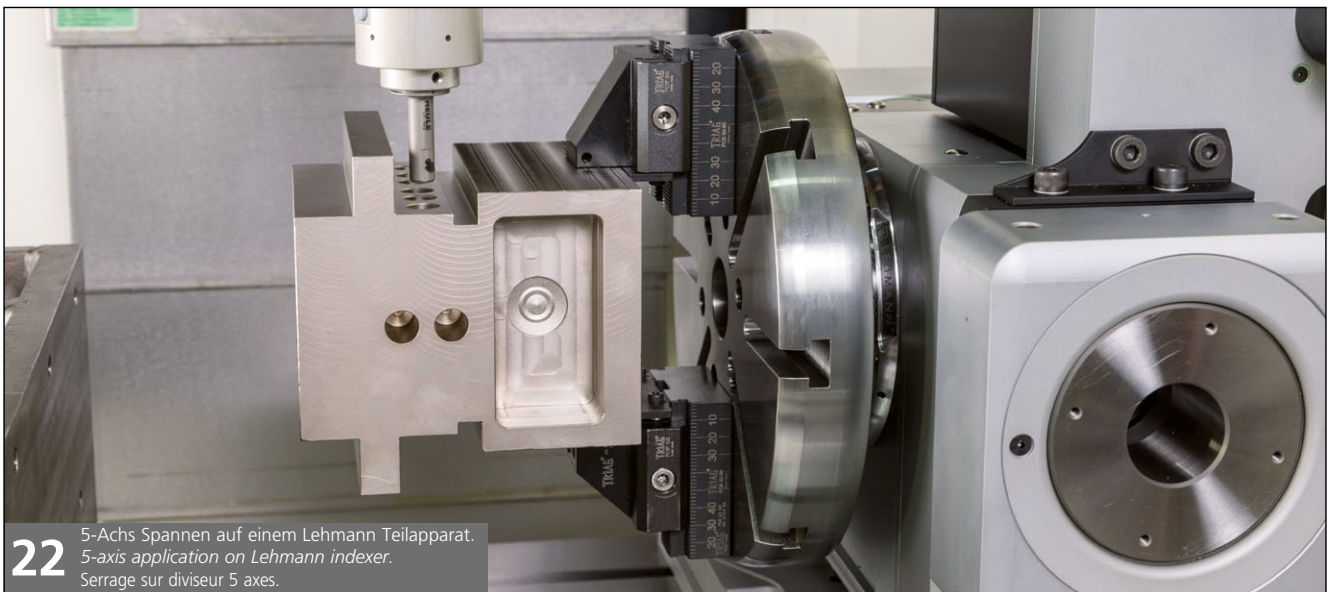

22

5-Achs Spannen auf einem Lehmann Teilapparat.
5-axis application on Lehmann indexer.
Serrage sur diviseur 5 axes.



23



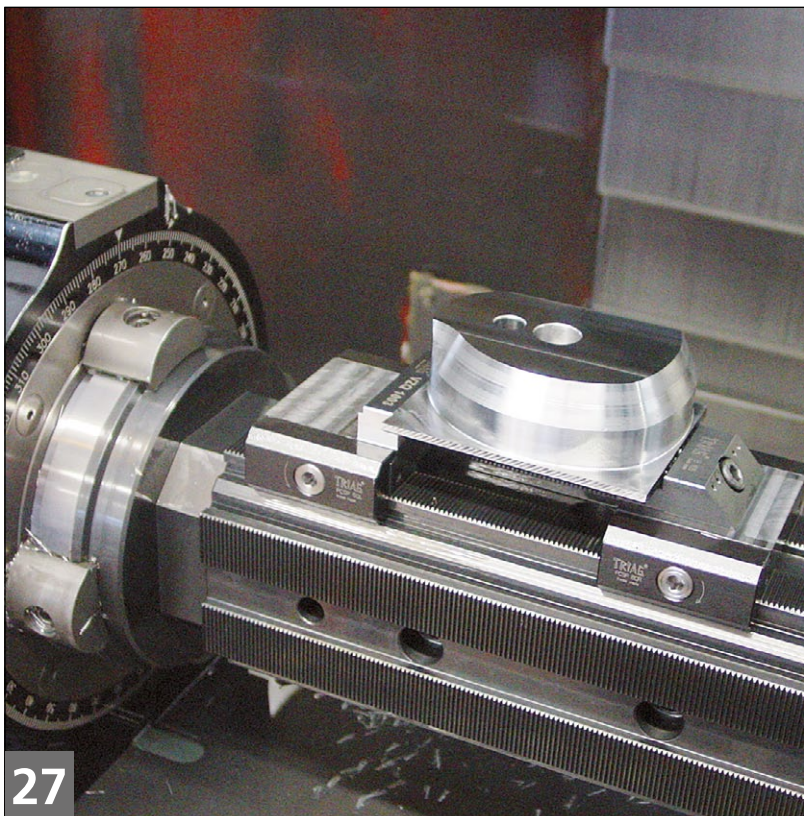

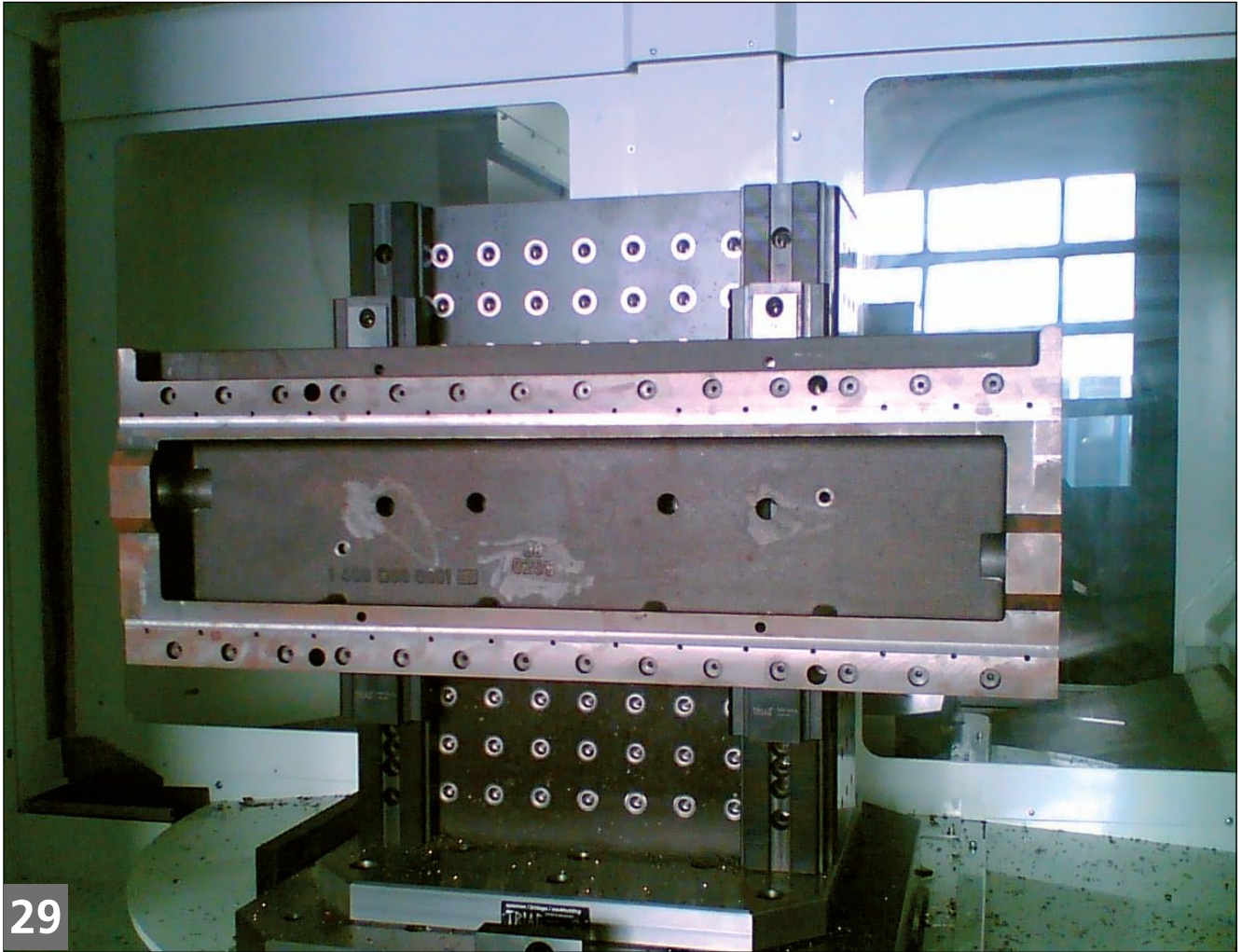

29

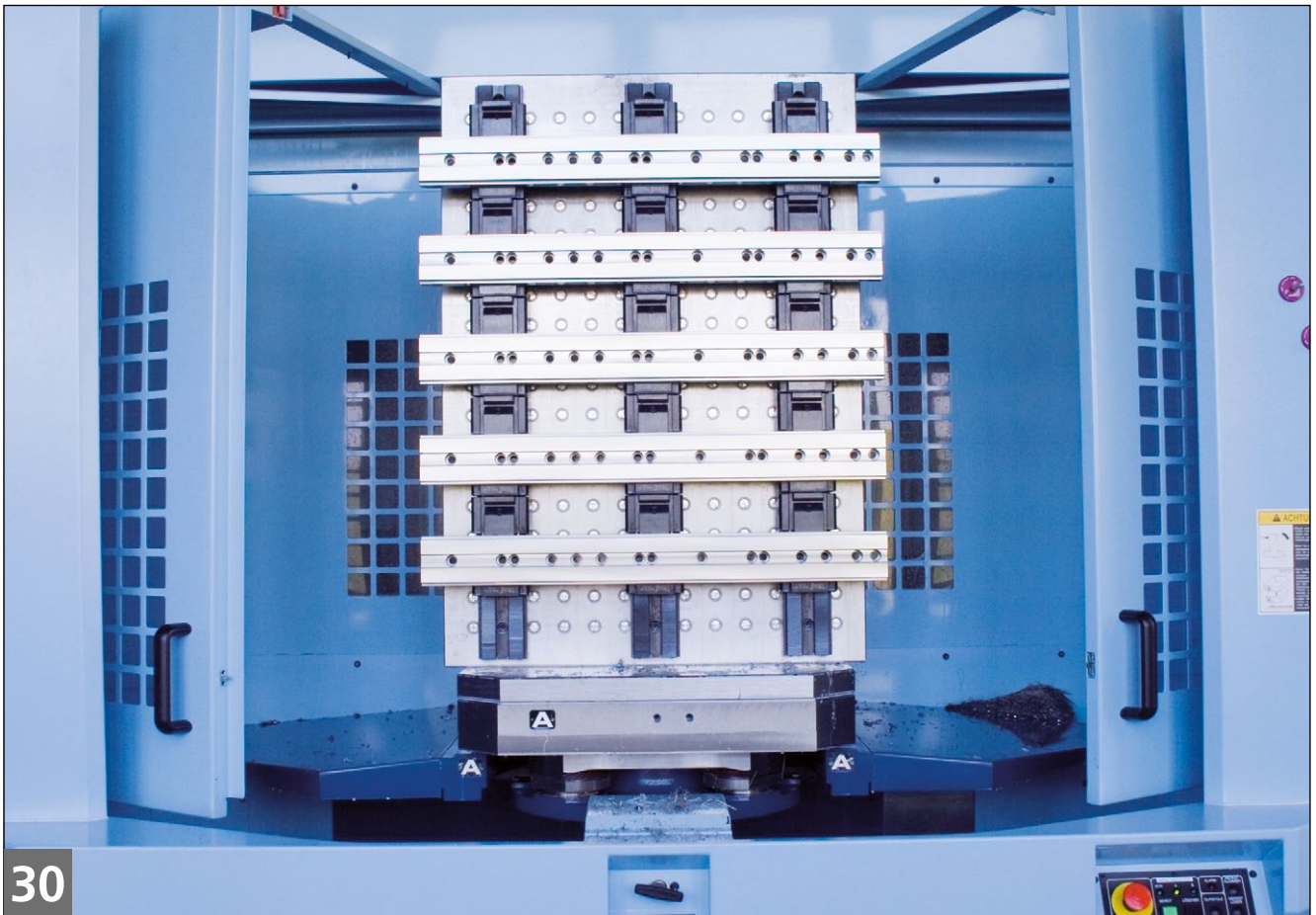

30

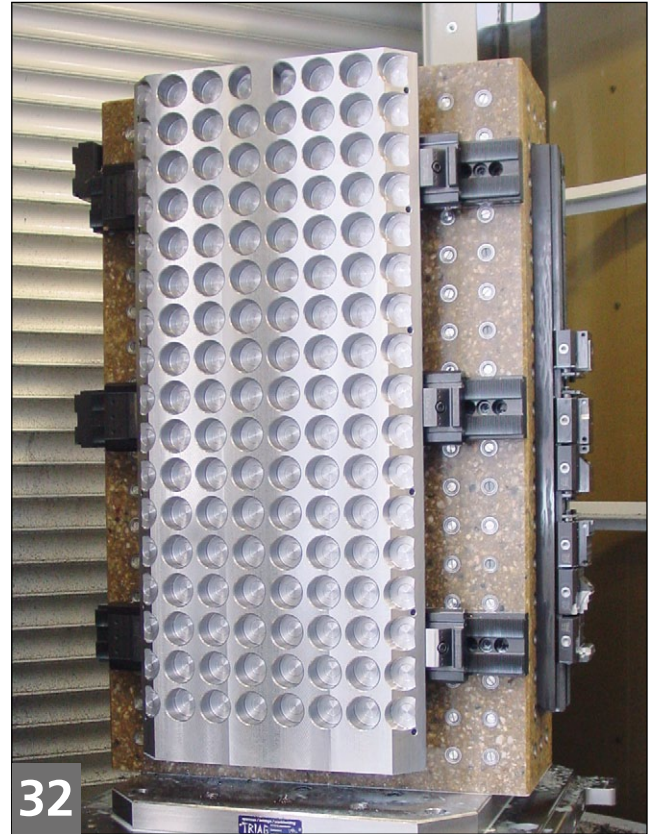
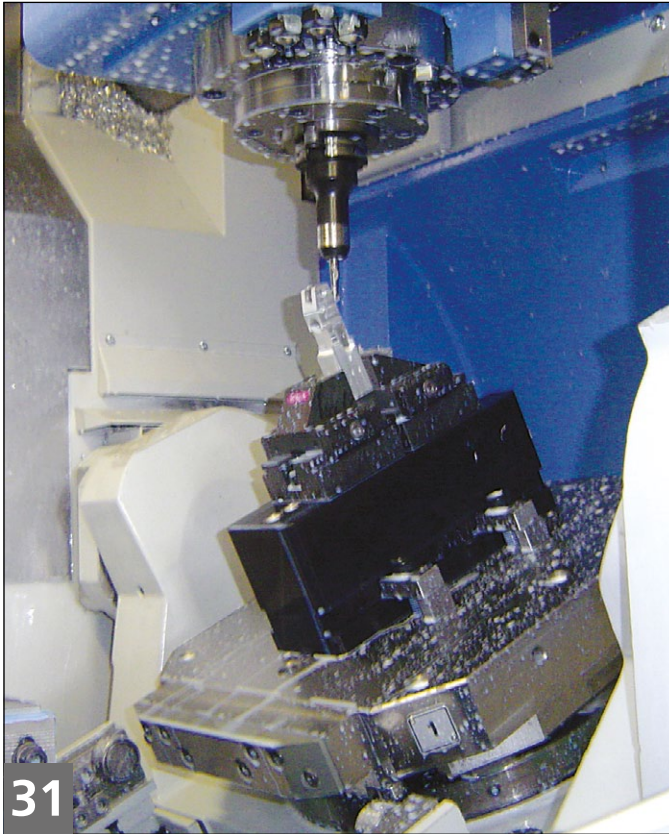

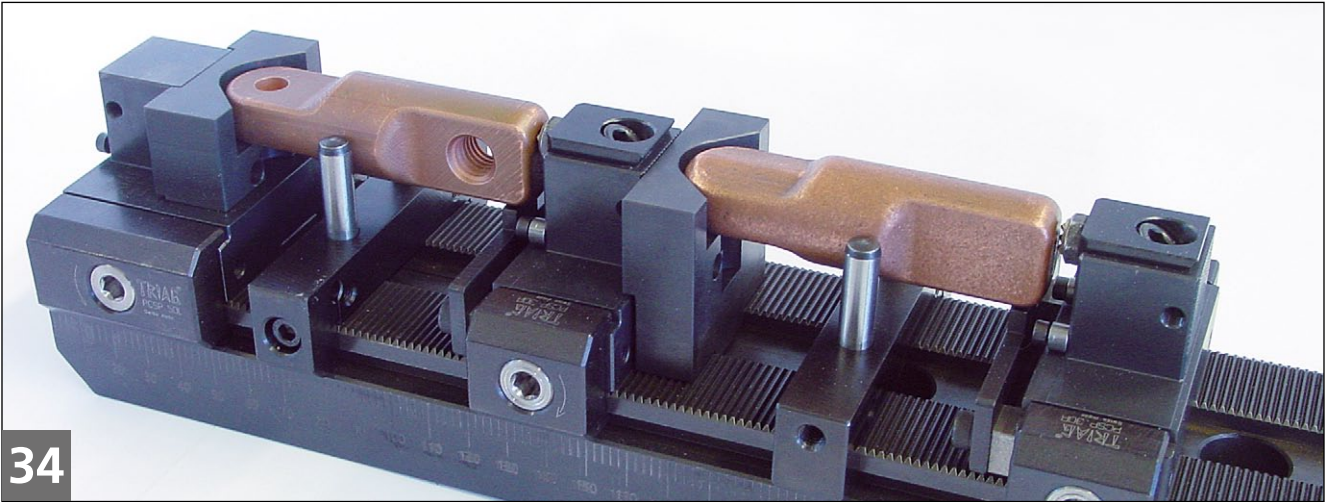

34

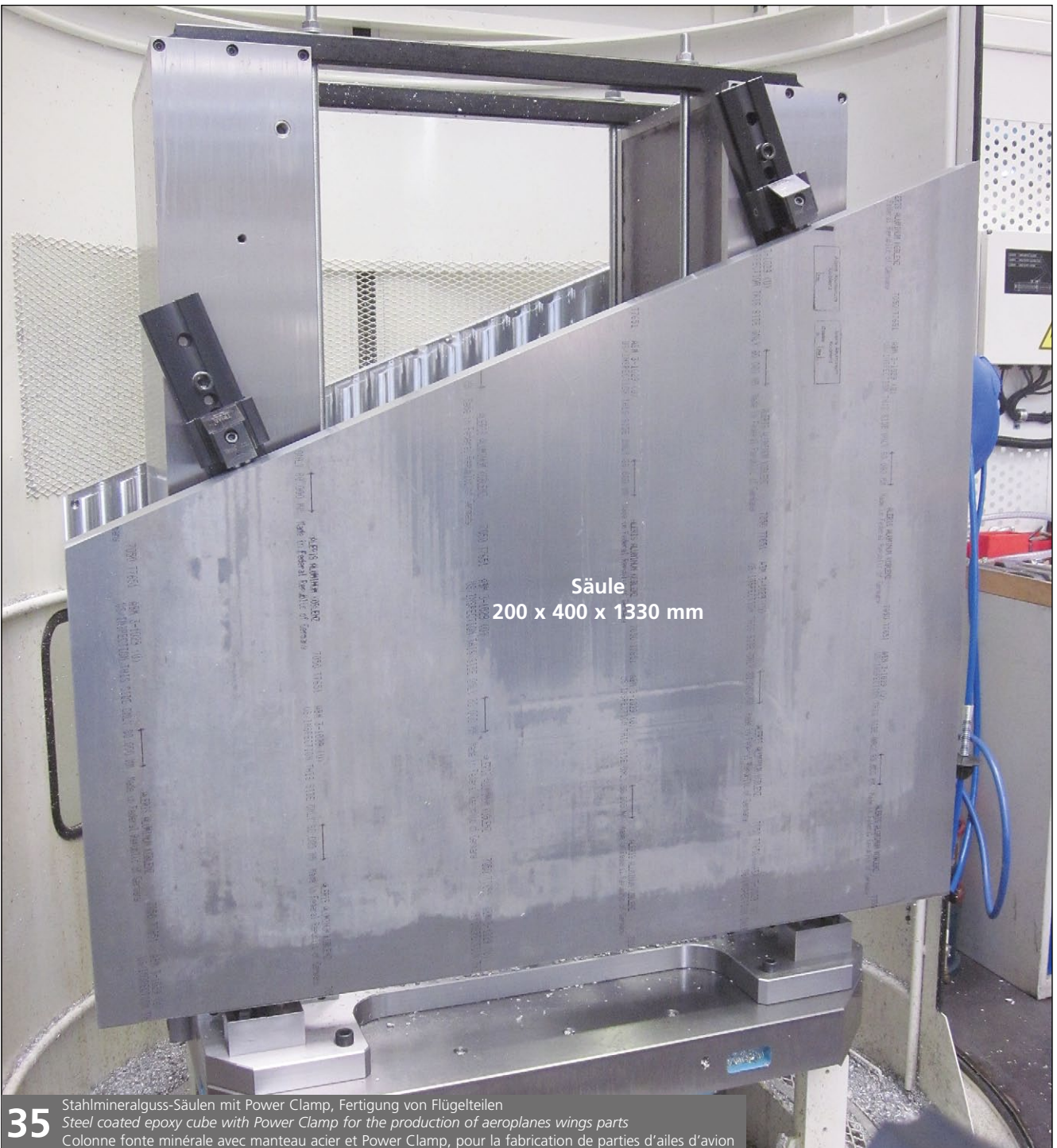

Säule
200 x 400 x 1330 mm

35

Stahlmineralguss-Säulen mit Power Clamp, Fertigung von Flügelteilen
Steel coated epoxy cube with Power Clamp for the production of aeroplanes wings parts
Colonne fonte minérale avec manteau acier et Power Clamp, pour la fabrication de parties d'ailes d'avion

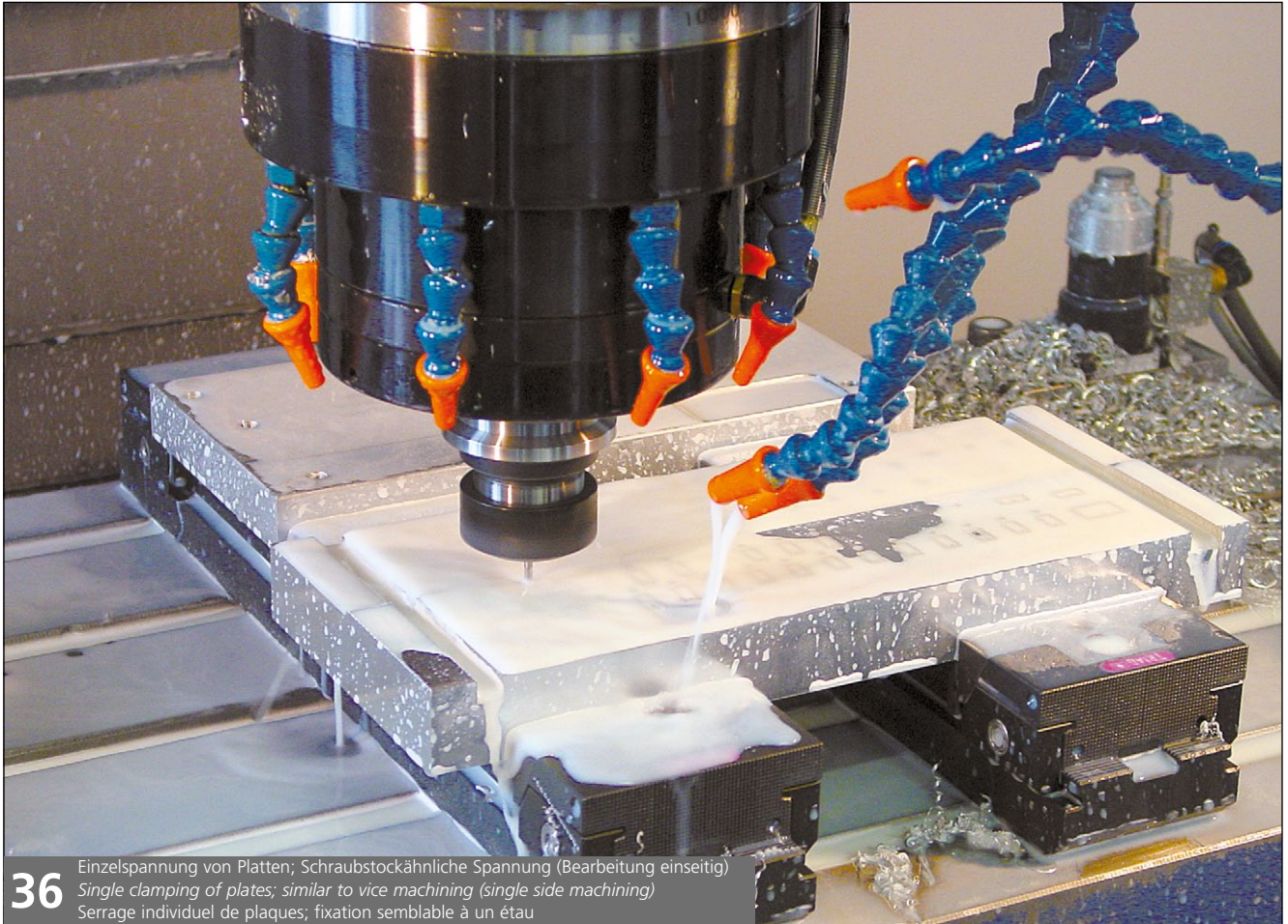

36 Einzelspannung von Platten; Schraubstockähnliche Spannung (Bearbeitung einseitig)
Single clamping of plates; similar to vice machining (single side machining)
 Serrage individuel de plaques; fixation semblable à un étou

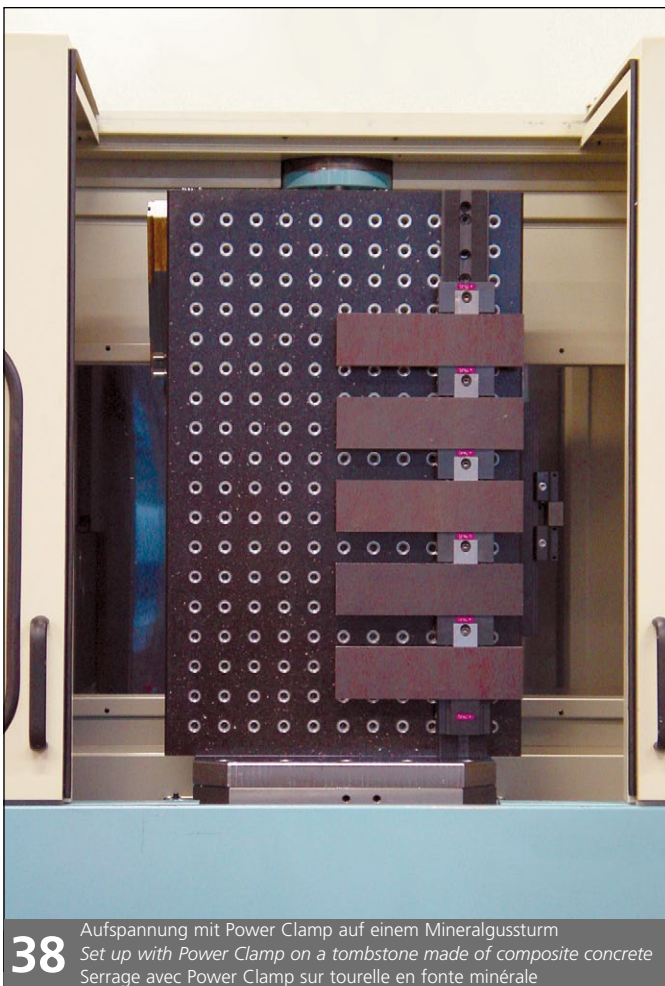

38 Aufspannung mit Power Clamp auf einem Mineralgussturm
Set up with Power Clamp on a tombstone made of composite concrete
 Serrage avec Power Clamp sur tourelle en fonte minérale

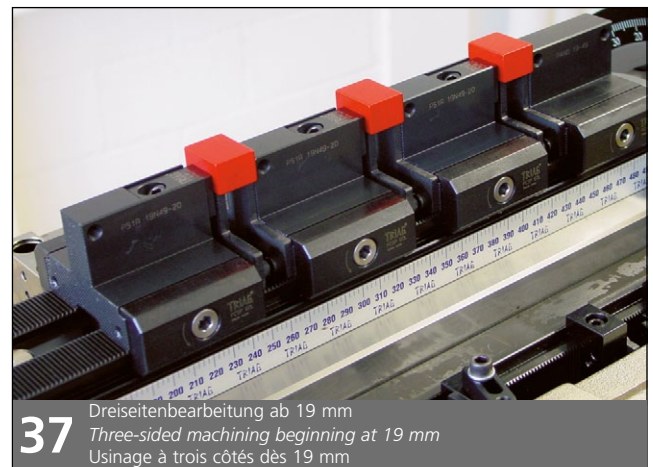

37 Dreiseitenbearbeitung ab 19 mm
Three-sided machining beginning at 19 mm
 Usinage à trois côtés dès 19 mm



39 oppSystem in Anwendung mit Werkstückwechsler
oppSystem in application with workpiece changer
 oppSystem en application avec le changeur de pièces

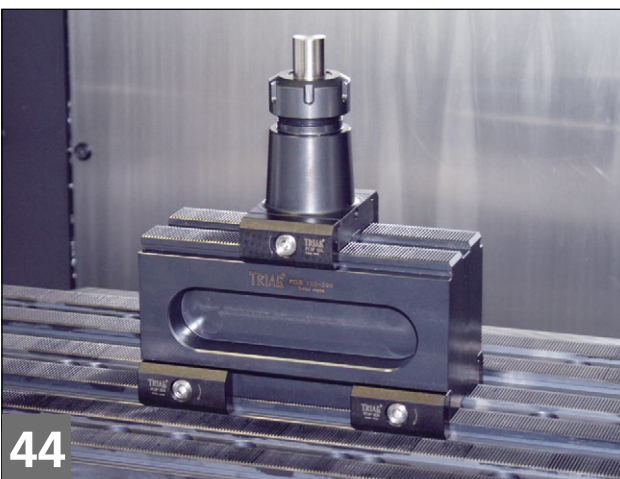
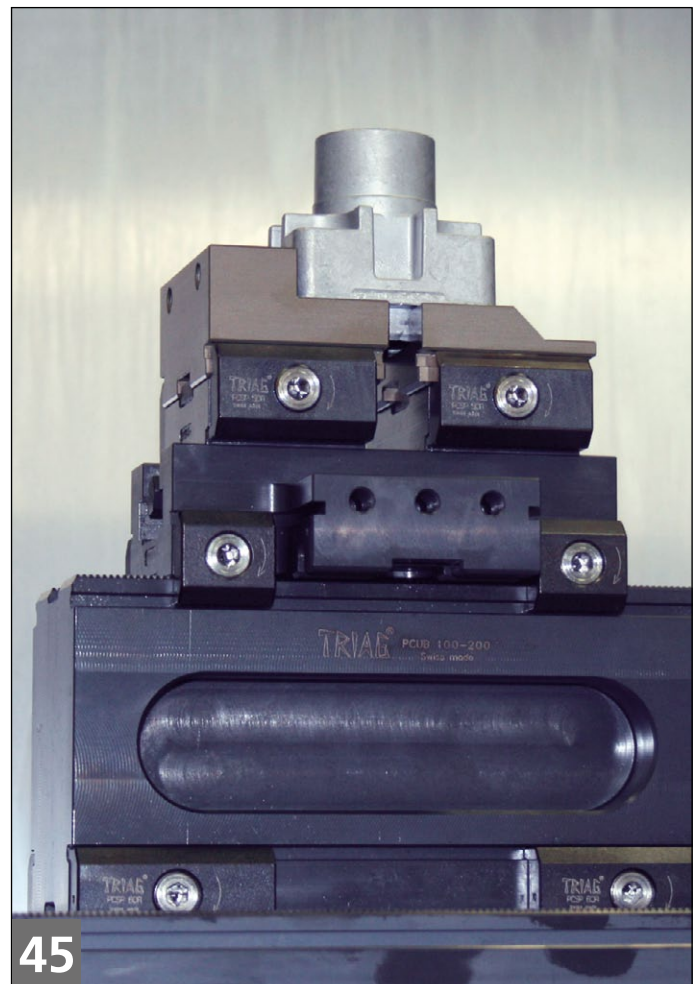
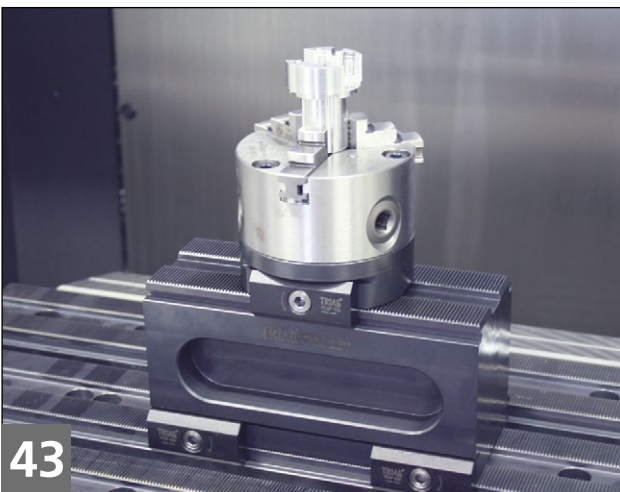
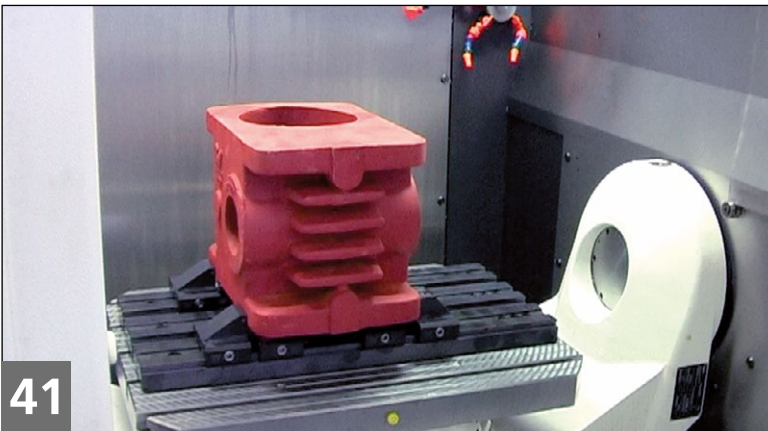
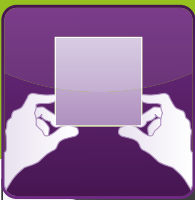

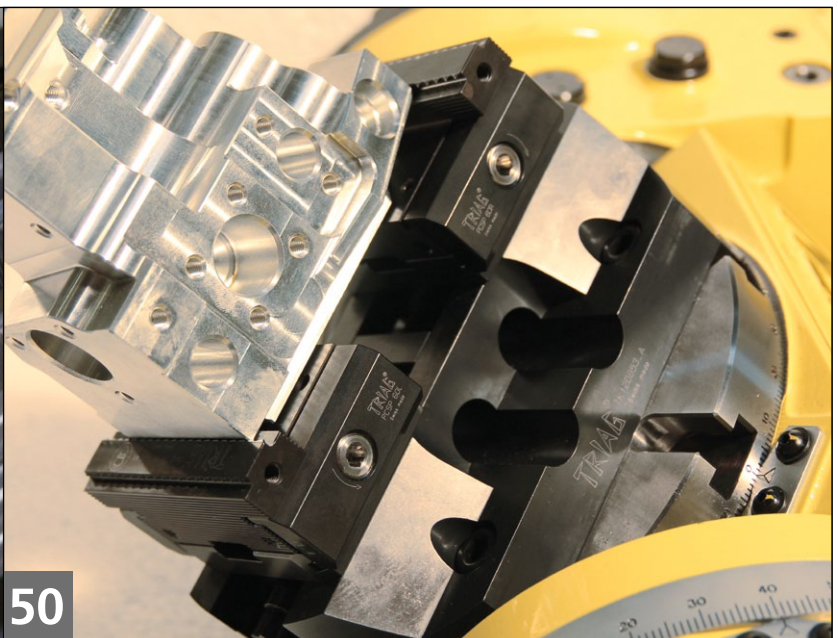
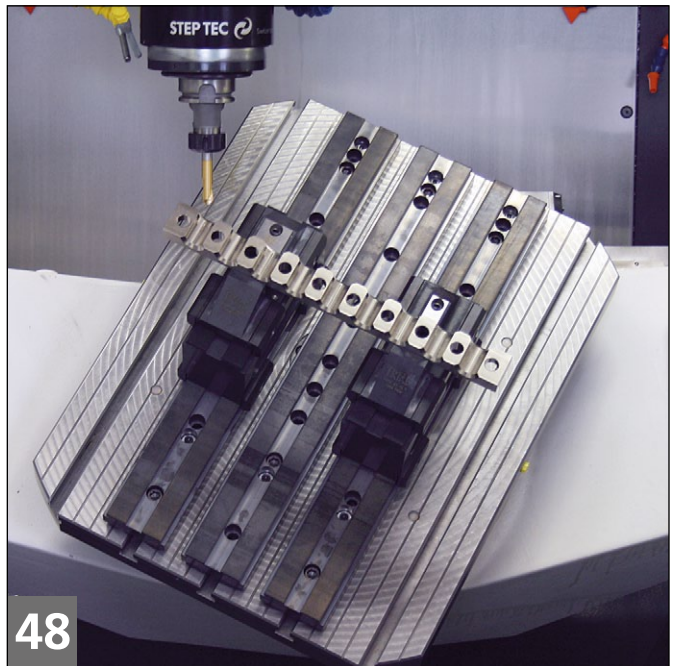
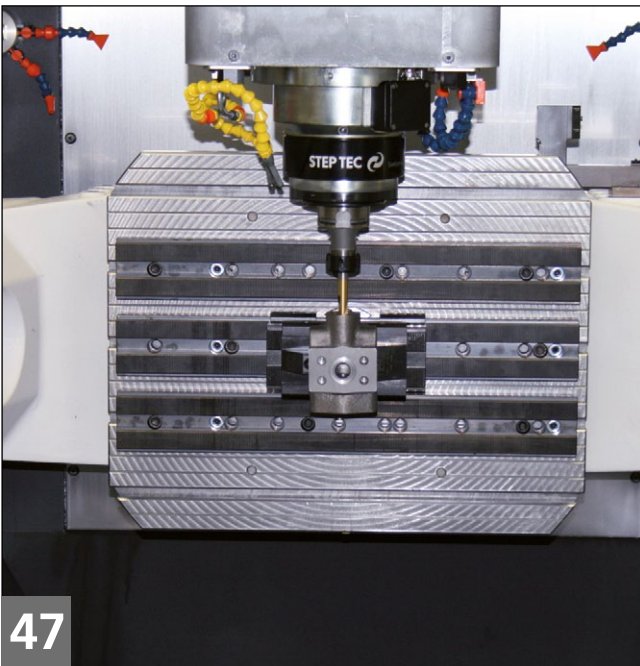
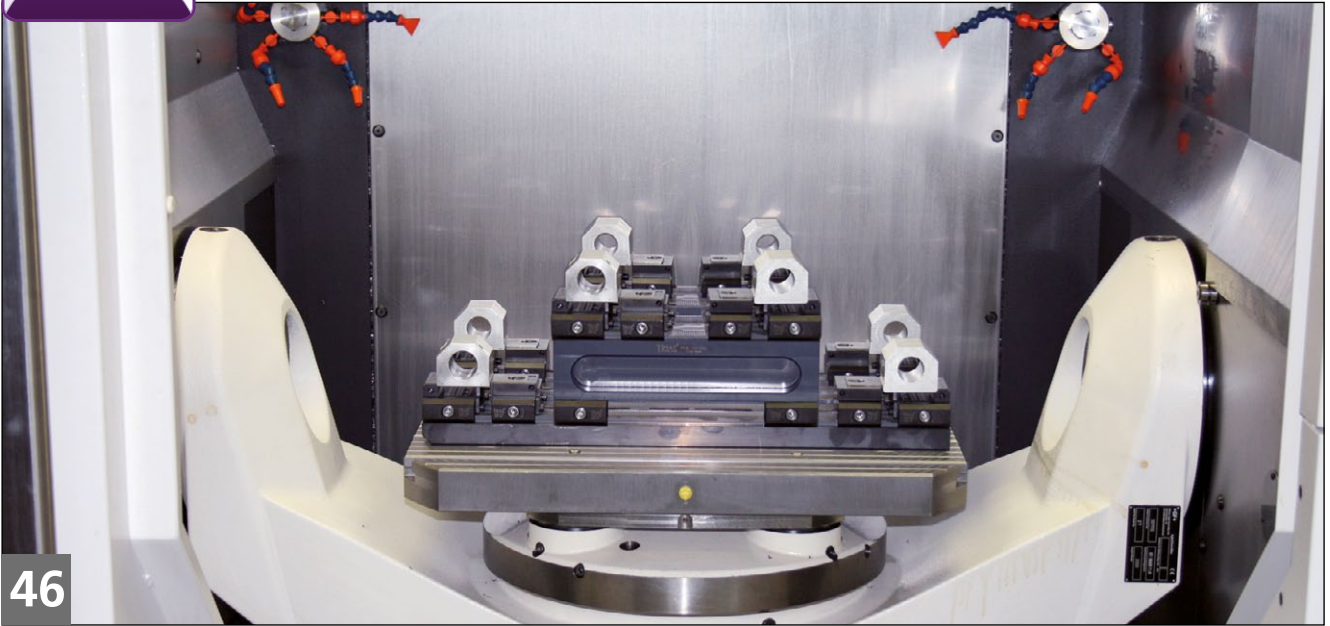

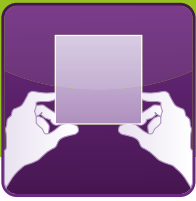

Modulares Mehrfachspannen auf 5-Achsenmaschinen

Immer öfter werden die 5-Achsenmaschinen in den Produktionsabläufen eingesetzt, um den Ansprüchen der heutigen effizienten Herstellung gerecht zu werden und weltweit wettbewerbsfähig zu bleiben. Die Werkstückspannung ist sehr anspruchsvoll und fordert die technischen Mitarbeiter ausserordentlich, wie auf den nachfolgenden Bildern dargestellt.

Vorteile der Triag 5-Achsen Spann-systeme:

- Die unteren Basisschienen dienen sowohl als mechanisches Nullpunktspannsystem, aber auch als Spannstock.
- Die Spannkraft wirkt direkt beim Werkstück, trotzdem ist das Werkstück ob klein, lang oder gross mit kurzen Werkzeugen sehr gut zugänglich. Die Einschränkung ist der Maschinentisch!
- Bei Dreiseitenbearbeitung ist auch Mehrfachspannung möglich.
- Es können über 50 verschiedene Spannmodule, sowie Rohmodule, Zentrischspanner, Dreibackenfutter, Spannanzangenfutter, Vakuumschraubmodule usw. aufgesetzt werden. Die Schnittstelle ist immer dieselbe.
- Sehr schnelles Umrüsten!
- Wenig Reinigungsaufwand, da keine T-Nuten vorhanden sind.
- Nicht nur speziell gut für 5-Achsenmaschinen geeignet, alle Teile können auf Horizontal- und Vertikalmaschinen genauso gut und universell eingesetzt werden.

Modular workholding system for 5-axis machines

Increasingly, the 5-axis machines are used in the production processes to be in accordance with the demands of today's efficient manufacturing and remain globally competitive. The workpiece clamping is very demanding and calls for extremely technical staff, as shown on the following pictures.

Benefits of Triag 5-axis workholding systems:

- *The lower base rails serve both as a mechanical zero-point clamping system, but also as a vice.*
- *The tension acts directly at the workpiece, the workpiece is still, whether small, long or large, very accessible with short tools. The constraint is the machine table!*
- *3-side machining is possible as well.*
- *There may be placed over 50 different clamping modules, as well as raw modules, self-centring modules, three jaw chuck, collet chuck, vacuum clamping modules and so on. The interface is always the same.*
- *Very fast setup!*
- *Reduced cleaning required, since no T-slots available.*
- *Are not only suitable for 5-axis machines, all parts can be used on horizontal and vertical machines as well and being used universally.*

Serrage modulaire modular sur machines à 5 axes

Les machines à 5 axes seront toujours plus souvent introduites dans le marché de la production avec les exigences efficaces d'aujourd'hui dans la fabrication et seront à la hauteur pour rester compétitives mondialement. Le serrage des pièces à usiner est très exigeant et demande des collaborateurs techniques expérimentés, comme représenté sur les images suivantes.

Avantages du système de serrage 5 axes de Triag:

- Le rail de base du dessous sert aussi bien comme point 0 mécanique du système de serrage, que comme étau.
- La force de serrage agit directement vers la pièce, que la pièce soit petite, longue ou grosse, avec des outils courts et un accès facile, la limite est la table de la machine.
- Avec l'usinage sur trois côtés le serrage modulaire est aussi possible.
- Plus de 50 divers modules de serrage, modules d'ébauche, modules centreur, mandrins à trois mors, mandrins pince de serrage, modules de serrage vacuum ect. viendront s'incruster. L'interface est toujours la même.
- Réajustage et réglage très rapide!
- Peu de temps pour le nettoyage, pas de rainures T sont ici présentes.
- Non seulement recommandé pour les machines à 5 axes, toutes les pièces peuvent être usinées sur machine horizontales et verticales de la même manière. Toujours avec la même interface.

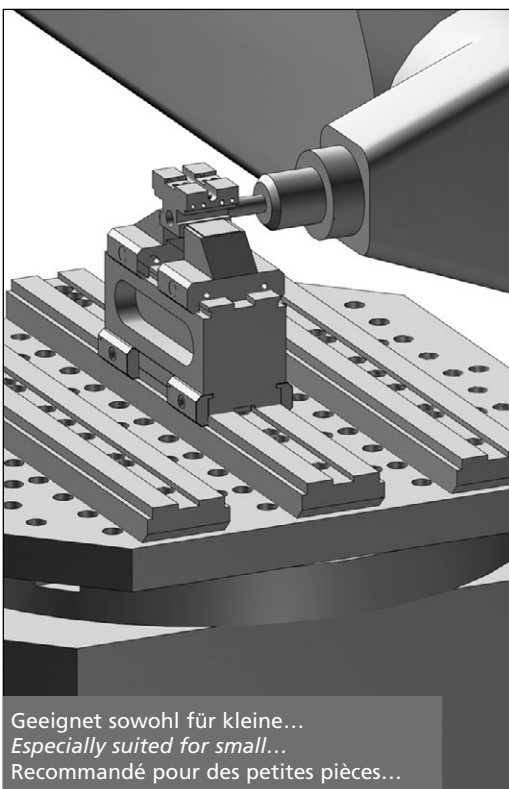

Geeignet sowohl für kleine...
Especially suited for small...
Recommandé pour des petites pièces...

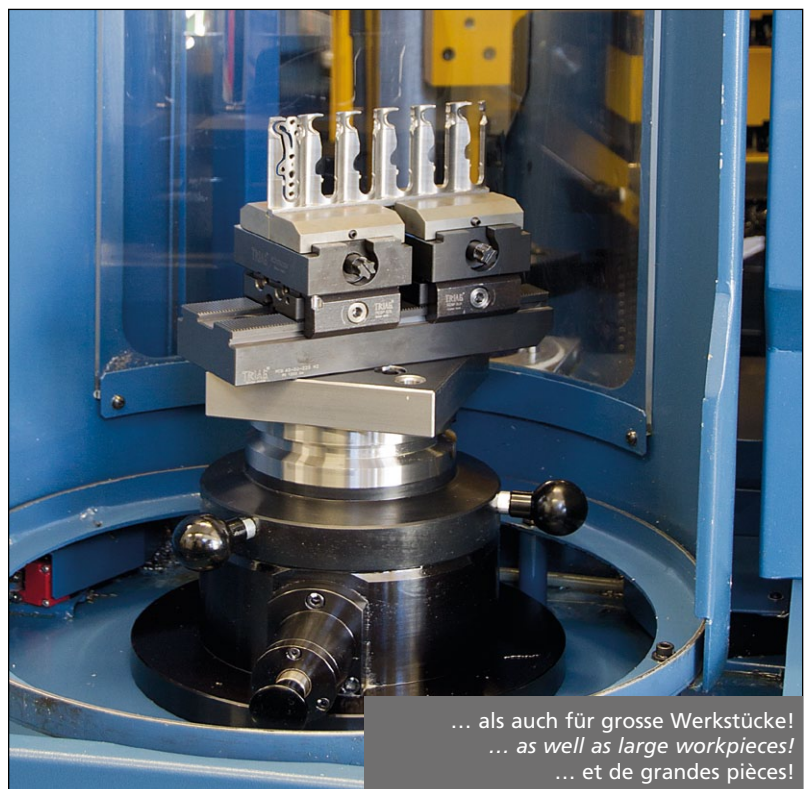

... als auch für grosse Werkstücke!
... as well as large workpieces!
... et de grandes pièces!



Der Spannstock und die Idee des Mehrfachspannens

Für viele Arbeiten ist auch heute noch der „Schraubstock“ das Spannmittel der Wahl. Bei einer einfachen Konfiguration können die Triag Modularspannsysteme auch als Spannstock eingesetzt werden (Bild). Ein solcher Spannstock kann später zu einem Mehrfachspannsystem erweitert werden. Alle Teile der Grundkonfiguration können weiterverwendet werden. Allfällige defekte Teile können problemlos ersetzt werden.

The machine vise and the idea of multiple workholding

For many machining tasks the conventional vise is still the favorite choice. If the batch has only a few parts the TRIAG multiple workholding systems can also be used as a simple machine vise (note picture). Should the need for a multiple workholding device arise at a later time, as a larger batch has to be machined for example, it is a matter of adding a few extra vise modules to do the job. All the components of the starter set may be used for the multiple layout. Consequently for future vise acquisitions only TRIAG multiple starter sets should be considered.

L'étau et l'idée des serrages multiples

Pour beaucoup de travaux l'étau est encore aujourd'hui le choix pour la fixation. Pour une configuration simple le système de serrage multiple de Triag peut aussi être utilisé comme étau (voir photo de droite) Un étau de ce genre peut être rapidement agrandi en système de serrage multiple. Toutes les pièces de la configuration peuvent être utilisées par la suite. Les pièces usées peuvent être remplacées facilement.



powerCLAMP

Beim Power Clamp ermöglicht eine Verzahnung mit 2 mm Teilung auf der Basisschiene ein schnelles und genaues Positionieren der Spann- und Anschlagmodule. Im Gegensatz zum Compact Clamp und vielen anderen Spannsystemen auf dem Markt, werden nicht vier Befestigungsschrauben pro Modul verwendet, sondern eine quer eingebaute Spindel. Diese, mit einem Rechts- und einem Linksgewinde versehen, zieht zwei mit schiefen Ebenen versehene Pratten zusammen. Mit dem Anziehen und Lösen dieser Spindel kann das Modul schnell umplatziert werden. Da die Spindel von beiden Seiten her zugänglich ist, können die Spannsysteme dicht beieinander platziert werden. Die Module werden von beiden Seiten her mit einer Kraft von 150'000 N auf die Basisschiene hinuntergezogen.

On the Power Clamp, teeth serrations (2 mm spacing) on the base rail allow exact positioning of the vise and end modules. In contrast to the Compact Clamp and many other clamping systems on the market, in which four hold down screws are necessary for each module, one transverse spindle is used. This central spindle, which has a right-handed and a left-handed thread, pulls two plates with angled faces together. These plates then lock the vise modules onto the base rail with a force of 150 kN on either side creating a solid bond between the two components. This feature allows very fast repositioning of the vise modules. Therefore setting up Power Clamp is accomplished within seconds particularly if the magnetic scale is being used. The spindle is accessible from both sides, so that the modules can easily be repositioned, even though adjacent clamping systems are very close.

Avec le Power Clamp vous avez à disposition une denture sur le rail de base avec un pas de positionnement de 2 mm qui vous permet rapidement et avec précision de positionner le module de serrage et d'appui sur le rail de base. Au contraire du Compact Clamp ou d'autres systèmes de serrage sur le marché ou vous avez quatre vis à serrer par module, le système Power Clamp est muni d'une seule vis transversale avec un filetage gauche et droite et deux pièces d'ancrage qui fixe le module sur le rail de base. En serrant ou desserrant cette vis vous avez rapidement déplacé votre module. Etant donné que vous pouvez atteindre cette vis des deux côtés vous pouvez placer vos deux étaux tout près l'un de l'autre et de ce fait vous économisez beaucoup de place. Les deux modules sont tirés vers le bas des deux côtés avec une force de 150'000 N sur le rail de base.

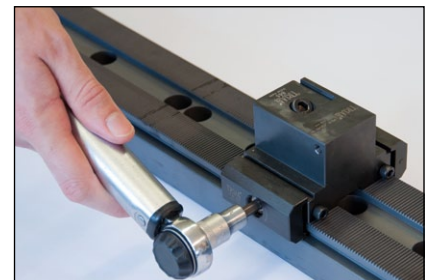

1. Eine Schraube lösen
 Unscrew
 Déserrer une vis

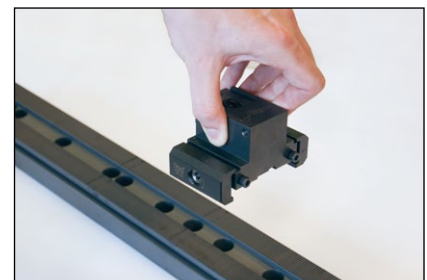

2. Abheben und neu platzieren
 Lift and change position
 Enlever et repositionner le module

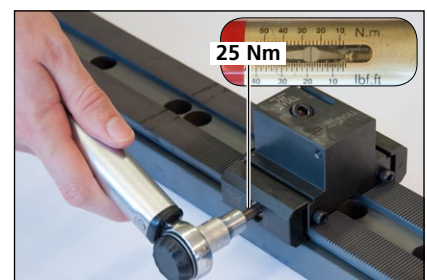

3. Eine Schraube anziehen
 Fasten one screw
 Serrer une vis



ACHTUNG / CAUTION / ATTENTION

WICHTIG: Vor dem Positionieren der Spannmodule für ein neues Werkstück, ist die Spannbacke ganz zurück zu stellen, dies gewährleistet eine sichere Spannung (siehe Bild A)!

IMPORTANT: Prior to setting up a new clamping module the clamping jaw of the vice module must be retracted all the way (see picture A)! This guarantees proper clamping of the new workpiece.

IMPORTANT: Avant le réglage d'un nouveau module, le mors doit être remis en position de départ, afin d'obtenir un serrage optimal (voir image A)!



Niederzug-Spannmodule Pull down module Modules avec mors descendant	Schraube Screw Vis	Drehmoment Torque Couple de torsion		Spannkraft Workholding force Force de serrage		
		Nm	(lb-ft)	daN	(lb)	t
		M5 + M6	4	3	500	1100
	5	3,7	580	1300	0,58	
	6	4,4	690	1500	0,69	
	7	5,2	780	1700	0,78	
	8	5,9	880	1930	0,88	
	9	6,6	980	2150	0,98	
	10	7,4	1020	2240	1,02	
	M6	12	8,9	1220	2680	1,22
	14	10,4	1450	3200	1,45	
	15	11	1520	3340	1,52	
	M8	4	3	410	900	0,41
	5	3,7	490	1080	0,49	
	6	4,4	560	1200	0,56	
	7	5,2	660	1450	0,66	
	8	5,9	730	1600	0,73	
	9	6,6	810	1790	0,81	
	10	7,4	900	1980	0,90	
	15	11	1520	3340	1,52	
	20	14,8	1810	4000	1,81	
	25	18,4	2100	4600	2,10	
	M10	10	7,4	400	890	0,40
	20	14,8	1400	3080	1,40	
	30	22,1	2000	4400	2,00	
	40	29,5	2800	6150	2,80	

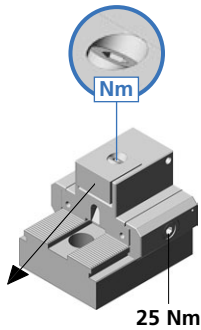

WICHTIG: Die angegebenen Drehmomente sind die absoluten Maximalwerte. Über die Spannkraften gibt die untenstehende Tabelle Auskunft.

IMPORTANT: The torque numbers specified represent the absolute maximum. The table at the bottom of this page provides further information on the workholding forces.

IMPORTANT: Les valeurs des couples de torsion mentionnés sont les valeurs maximales absolues. Pour les forces de serrage vous pouvez vous référer à la table ci-dessous.

Spannbacken und Schrauben regelmäßig fetten!

Lubricate clamping jaw and screw regularly with grease!

lubrifiez le mors et les vis régulièrement!

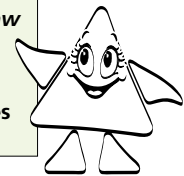

Linear-Spannmodule
Linear module
Module linéaire

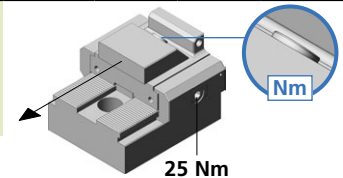

Schraube Screw Vis	Drehmoment Torque Couple de torsion		Spannkraft Workholding force Force de serrage		
	Nm	(lb-ft)	daN	(lb)	t
M8	10	7,4	400	880	0,4
	20	14,8	800	1770	0,8
	30	22,2	1200	2660	1,2
	40	29,6	1600	3550	1,6

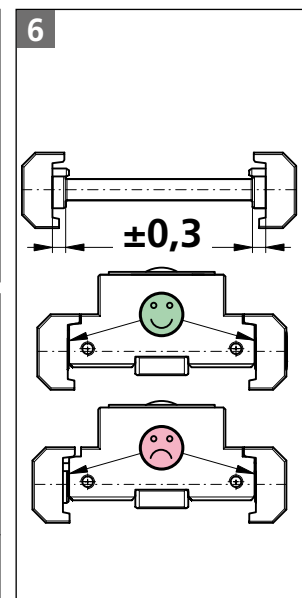
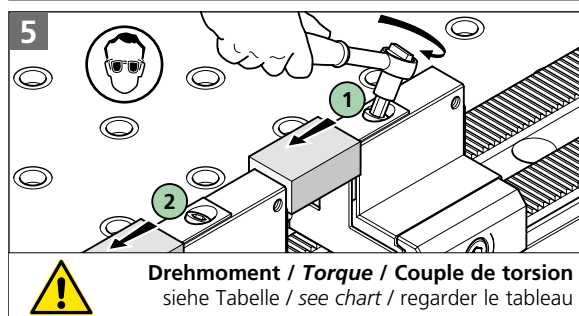
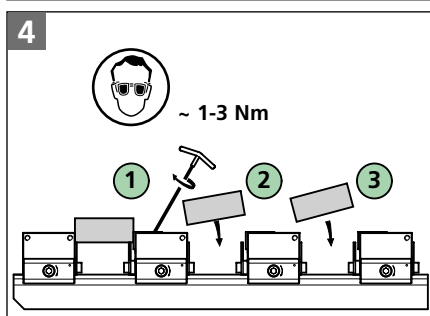
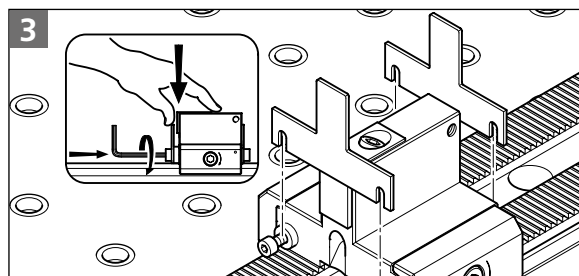
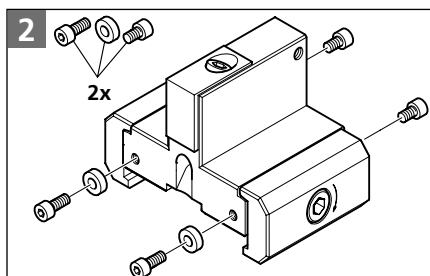
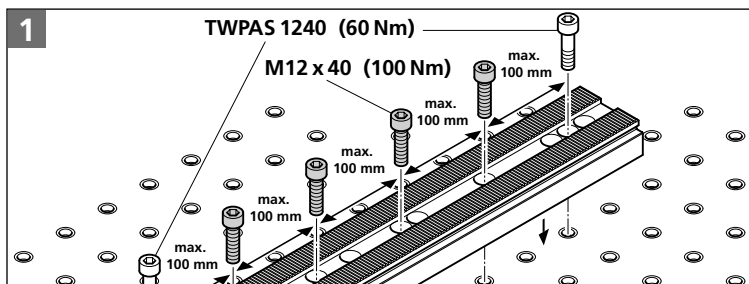

Drehmoment / Torque / Couple de torsion
siehe Tabelle / see chart / regarder le tableau

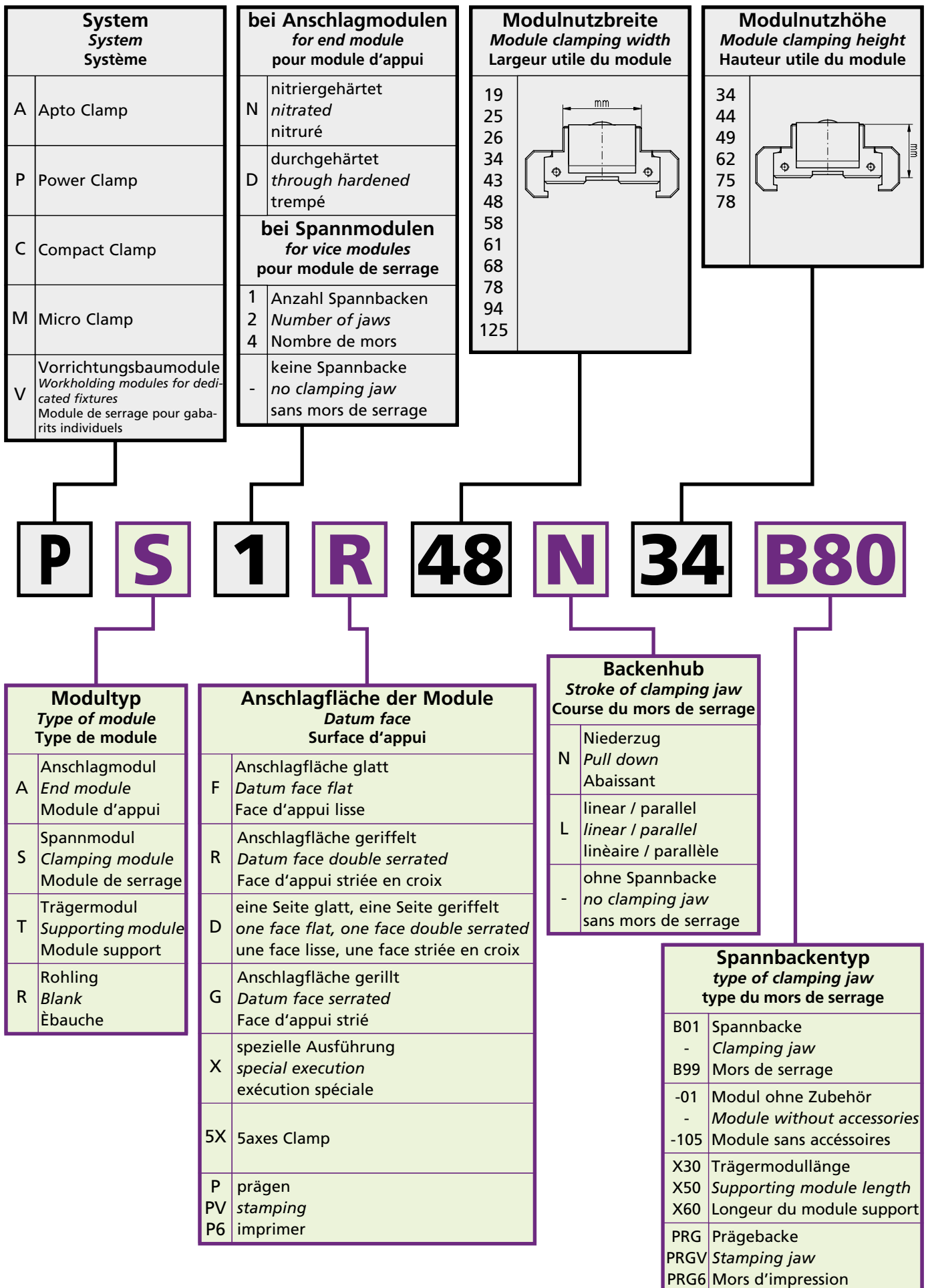

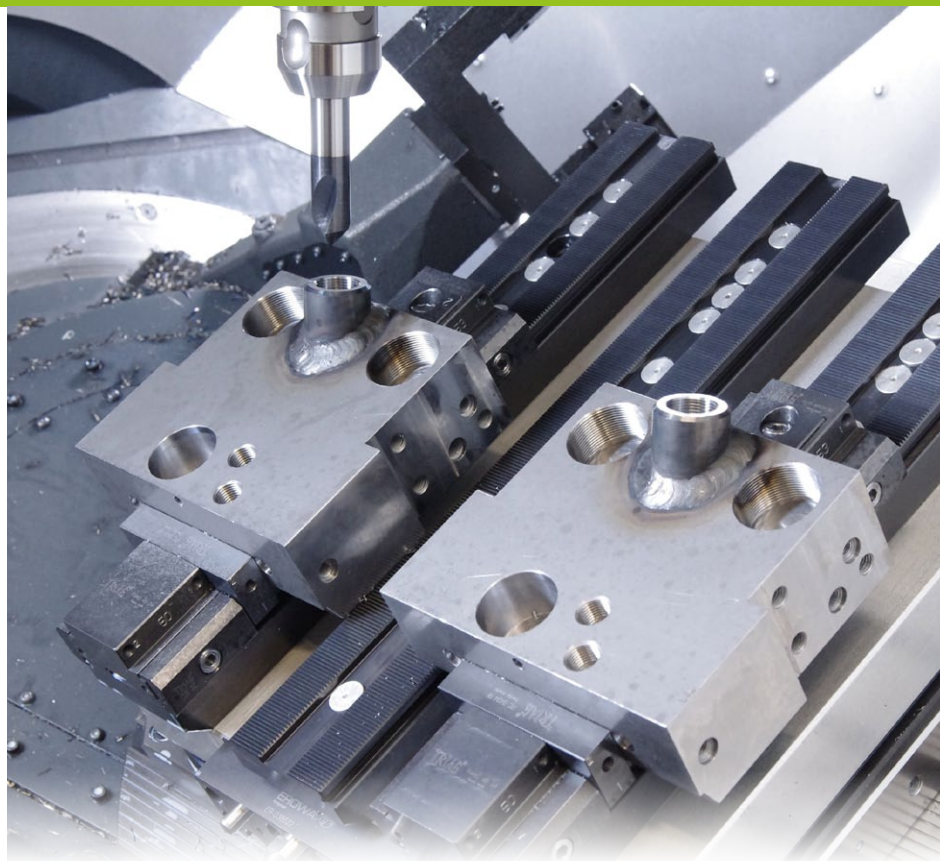

Die Basisschiene ist die Grundlage des Power Clamp Spannsystems

Der Einsatz der Basisschiene als Modularspannstock ist jedem Mechaniker ein Begriff. Die Vorteile ihres Einsatzes als mechanisches Nullpunktsystem sind in der Zwischenzeit ebenfalls ins Planungsdenken der mechanischen Fertigung eingeflossen.

Die Power Clamp-Schiene dient als Basis für über 180 verschiedene Spannmodule, Zentrischspanner, Rohlingsmodule und Vakuumplatten.

The serrated base rail is the basic structure of the Power Clamp workholding system

Using the base rail as a modular workholding vise is standard practice to any mechanic. The advantages of using it as a zero point system have also widely influenced the planning stages of mechanical production.

The Power Clamp base rail serves as a supporting plate for more than 180 different clamping modules, self centring vises, blank modules and vacuum clamping plates.

Le rail de base est le fondement du système de serrage Power Clamp

L'utilisation du rail de base comme étau modulaire est pour chaque mécanicien un concept. Les avantages des utilisations comme système point zéro mécanique.

Comme base le rail Power Clamp s'utilise pour plus de 180 modules de serrage différents; serrage centreur, modules ébauches et table vacuum.

Base rails in inch
www.triag-int.ch/inch.pdf



EROWA UPC R 50
ER 018570 / ER 016003

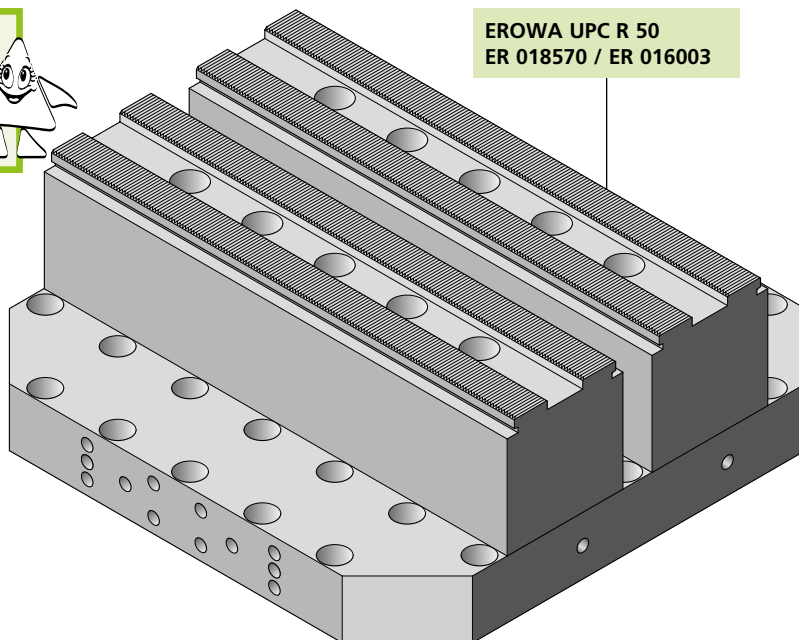



PCB 60-90 kg ~1,8

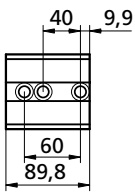

PCB 25-300 kg ~5,4

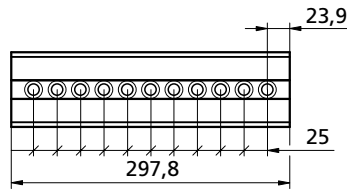

PCB 40-50-500 kg ~9,9

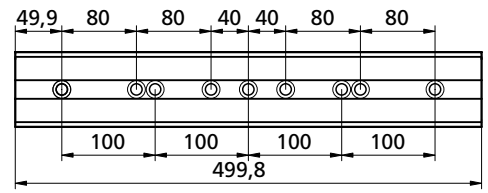

PCB 40-50-125 kg ~2,3

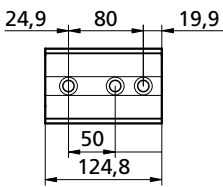

PCB 25-200 kg ~3,6

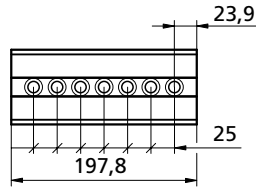

PCB 40-50-550 kg ~10,8

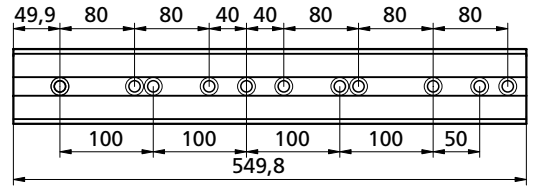

PCB 40-50-220-W2 kg ~4,3

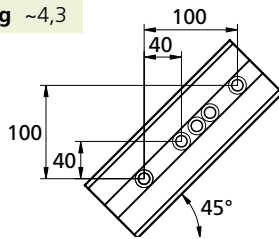
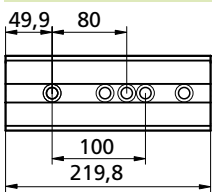

PCB 40-50-600 kg ~11,8

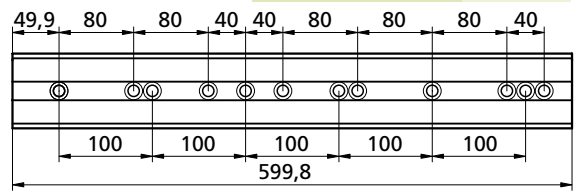

PCB 25-50-250 kg ~4,8

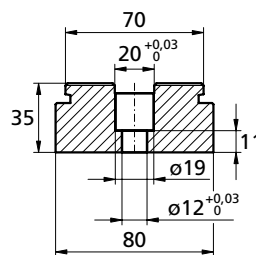
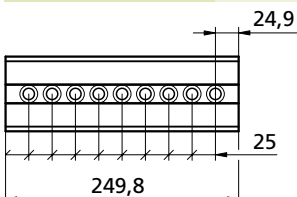

PCB 40-50-650 kg ~12,8

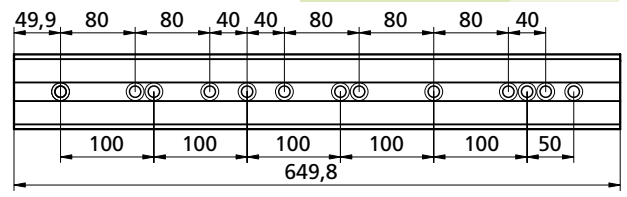

PCB 50-320 kg ~6,0

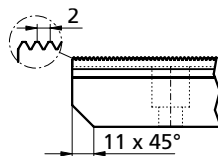
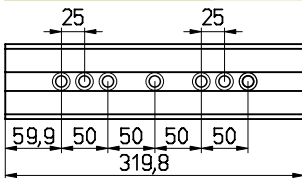

PCB 40-50-700 kg ~13,8

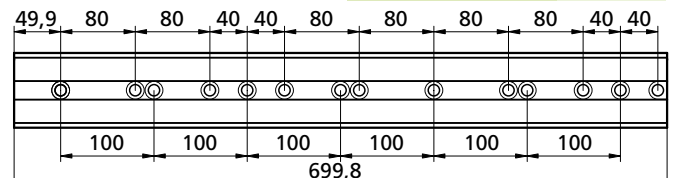

PCB 40-50-350 kg ~6,9

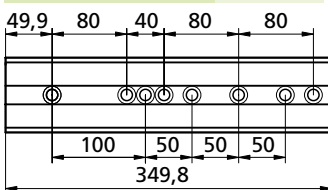

PCB 40-50-750 kg ~14,8

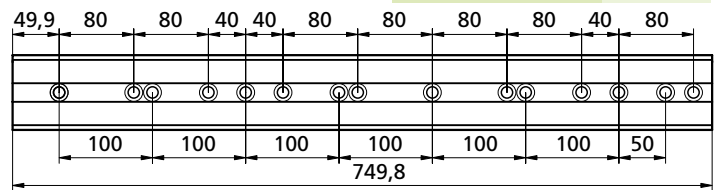

PCB 40-50-400 kg ~7,9

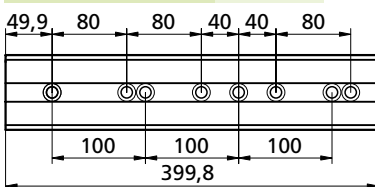

PCB 40-50-800 kg ~15,3

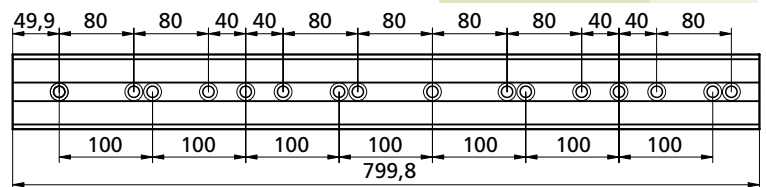

PCB 40-50-450 kg ~8,9

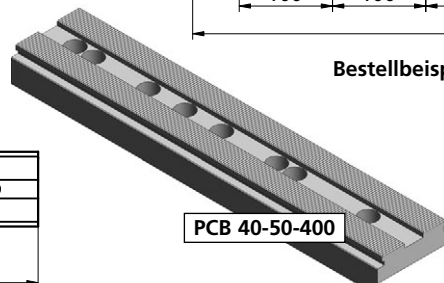
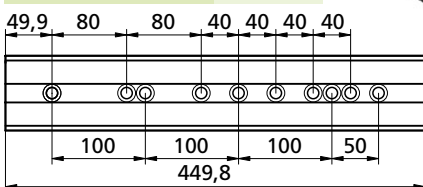

Bestellbeispiel / Ordering example / Exemple de commande:
PCB 40-50-125

Base rails in inch
www.triag-int.ch/inch.pdf





PCB 50-320 H60 kg ~6,9

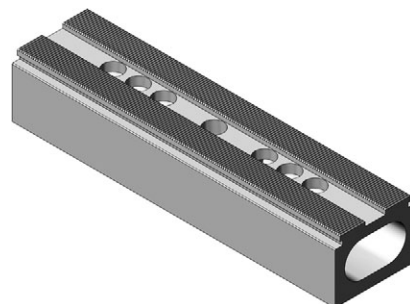
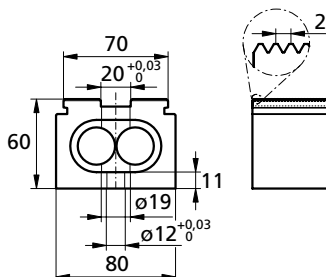
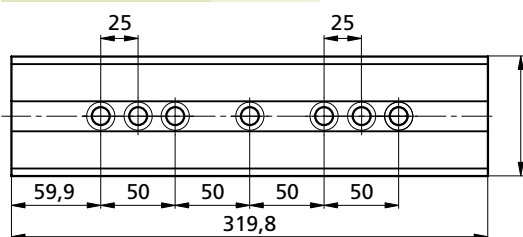

PCB 100-400 H60

- 1x TB140546
 - 2x M6x12 DIN 912
 - 2x SM1136-18
- kg ~14,0

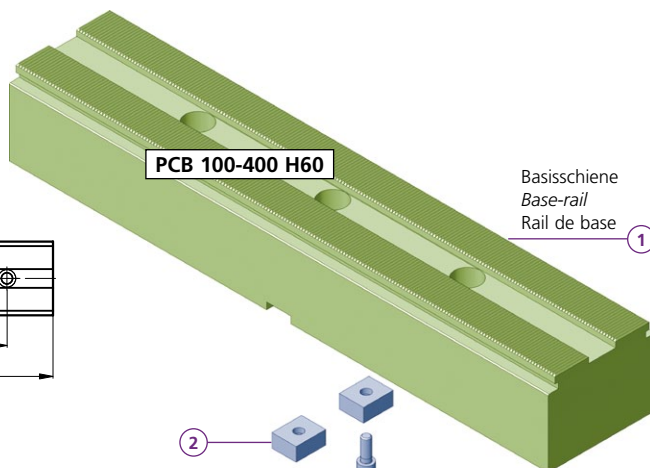
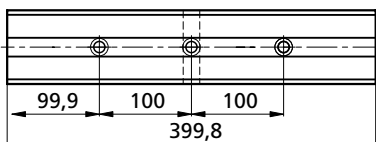

Basisschiene
Base-rail
Rail de base

PCB 100-500 H60

- 1x TB140553
- kg ~17,4

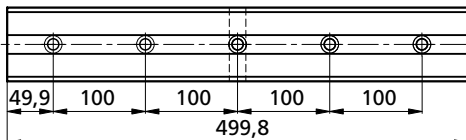

PCB 100-600 H60

- 1x TB140556
- kg ~21,0

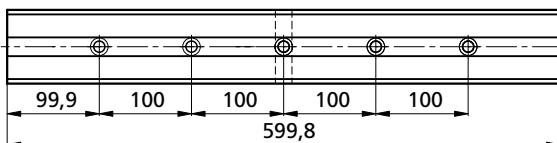

PCB 100-650 H60

- 1x TB140559
- kg ~22,6

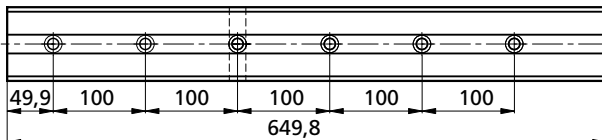

PCB 100-690 H60

- 1x ZL100122
- kg ~23,3

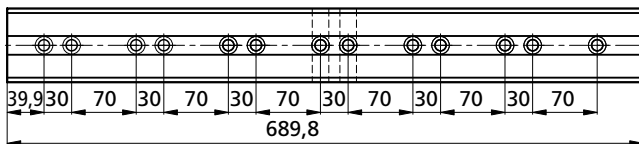

PCB 100-850 H60

- 1x TB140562
- kg ~29,0

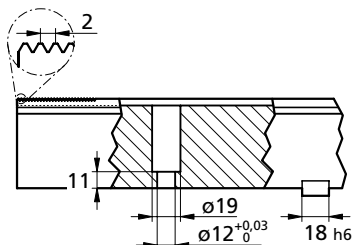
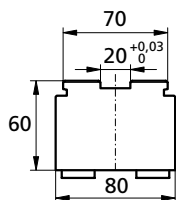
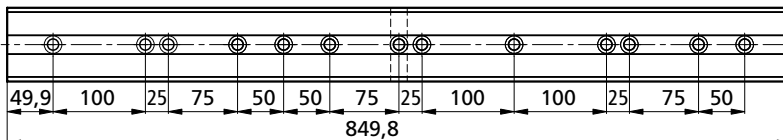

Bestellbeispiel / Ordering example / Exemple de commande:
1x PCB 100-400 H60 & 2x M6x16 DIN 912 & 2x SM1136-18



PCB 40-50-125 H80 kg ~7,5

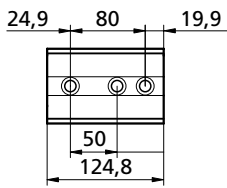

PCB 50-320 H80 kg ~14,4

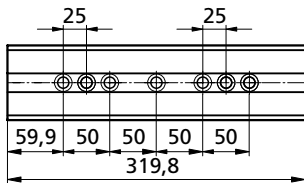

PCB 50-350 H80 kg ~15,8

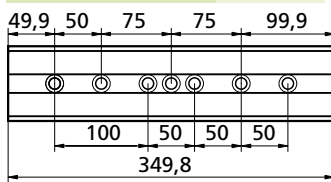

PCB 50-400 H80 kg ~18,2

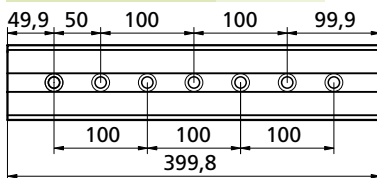

PCB 50-450 H80 kg ~20,3

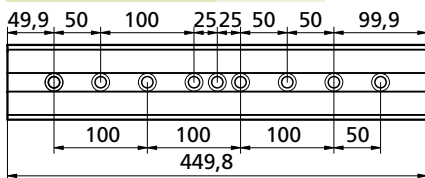

PCB 50-500 H80 kg ~22,8

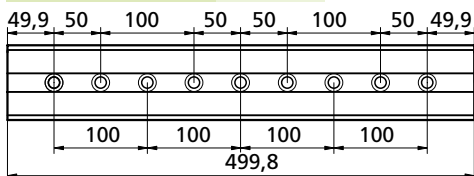

PCB 50-550 H80 kg ~24,8

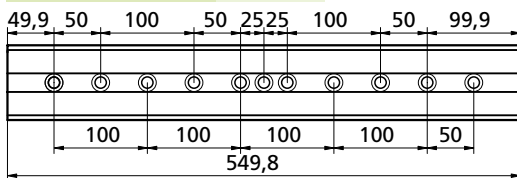

PCB 50-600 H80 kg ~27,3

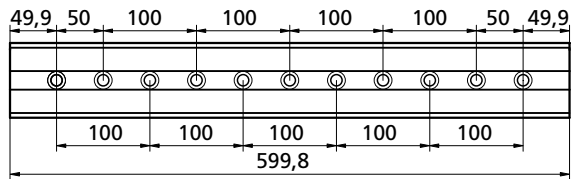

PCB 50-650 H80 kg ~29,4

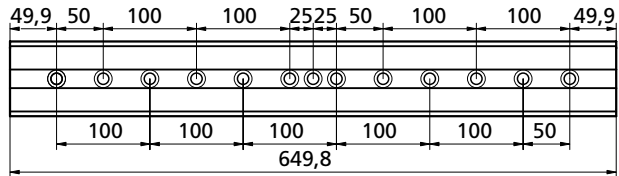

PCB 50-700 H80 kg ~31,8

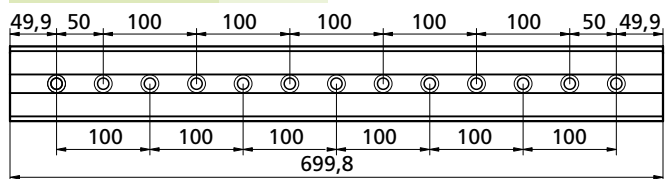

PCB 50-750 H80 kg ~33,9

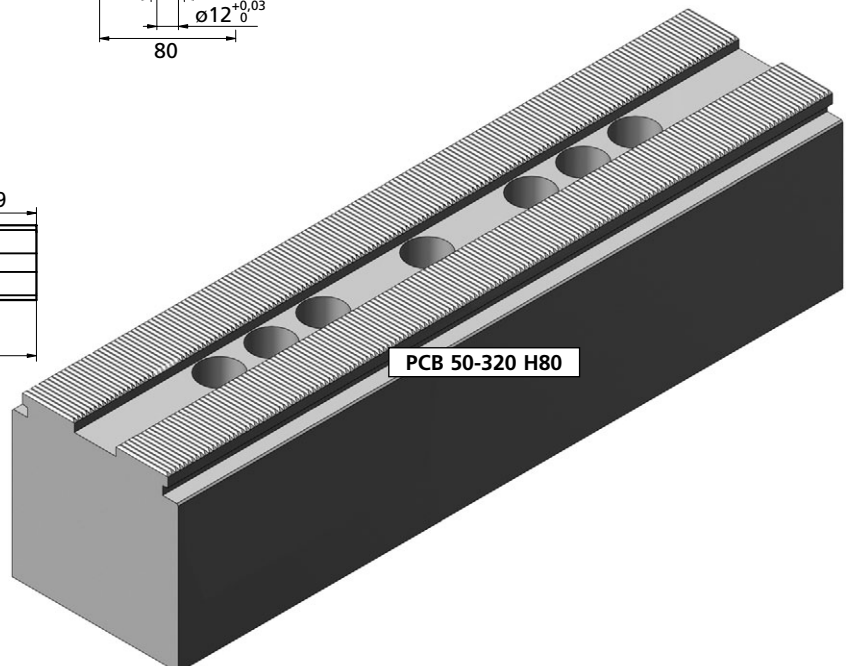
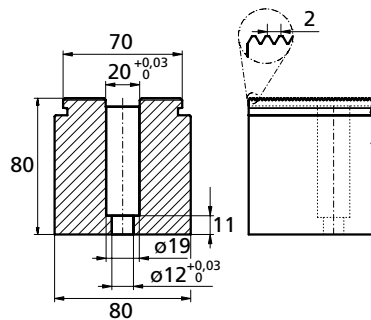
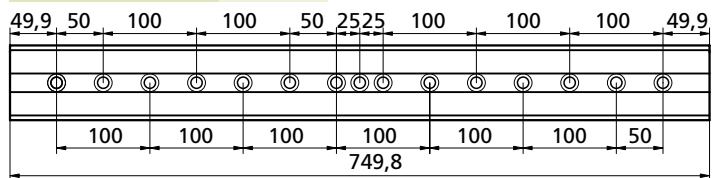

PCB 50-320 H80

PCMB 50-600 H175 kg ~39

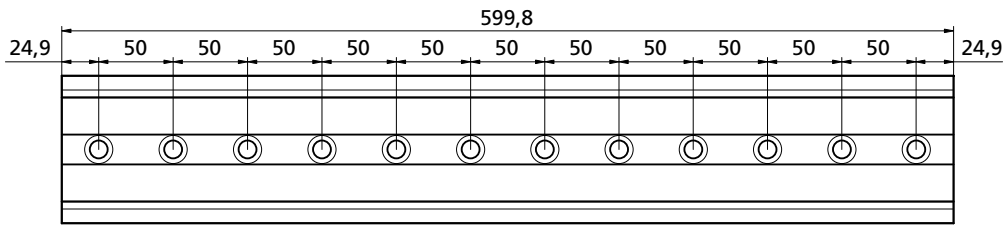

PCMB 50-500 H175 kg ~34

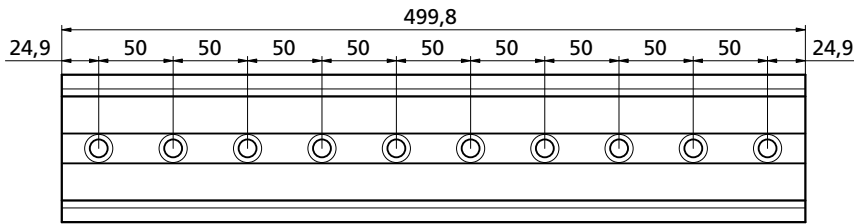

PCMB 50-400 H175 kg ~27

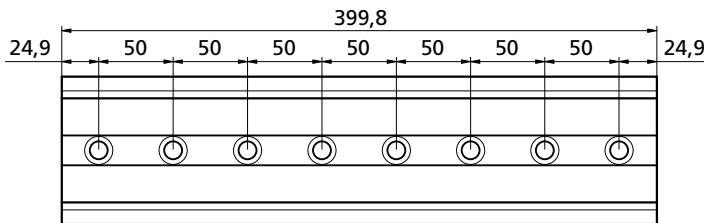

PCMB 50-300 H175 kg ~22

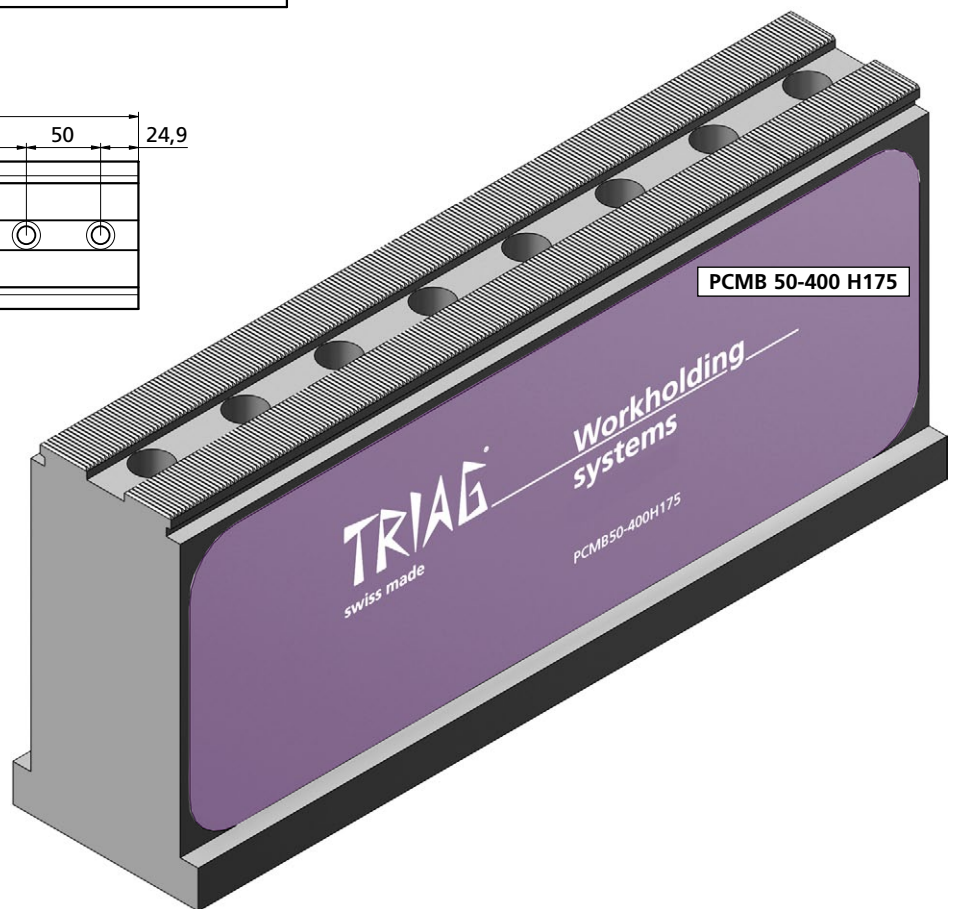
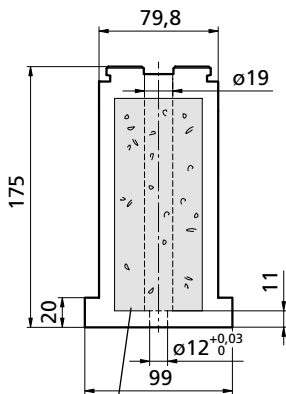
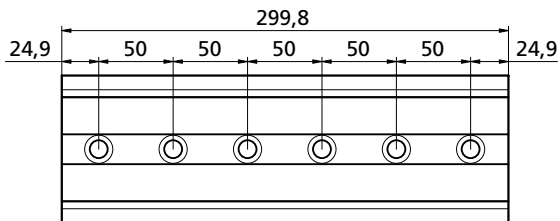

Epoxy Mineral
 Für gute Vibrationsdämpfung
 For brilliant dampening effect
 Pour athé mutation des vibrations excellente



**Kupplungsstücke für PCB Basis-
 schiene auf Mineralguss-Türmen**

Mit diesen Kupplungsstücken ist es möglich, die PCB Basisschienen zu verlängern. Aufgrund des durchgängigen Kraftschlusses wird eine übermäßige Belastung des Mineralgussturmes vermieden. Erforderlich ist eine Modifikation der Enden der Basisschienen gemäss der untenstehenden Zeichnung durch den Anwender. Selbstverständlich können neue Schienen bereits mit dieser Modifikation ausgeliefert werden.

So können die zwei Kupplungsstücke montiert werden, die nach dem Platzieren der Schienen eingesetzt und festgezogen werden. Eine zusätzliche Schraube (B) mit Federring nimmt allfällige, senkrecht zur Befestigungsfläche auftretende Kräfte auf.

**Coupling element for PCB base
 rails mounted on epoxy tomb-
 stones**

With this coupling element, it is possible to extend the PCB base rail by a second rail. Due to the frictional connection, the behaviour of the associated items is approximate to the behaviour of a continuous rail. A modification according to the drawing below (made by the customer) is required at the end of the base rails.

New base rails can be supplied with this modification. So the two coupling elements can be placed between the base rails. An additional screw (B) with a spring ring is taken the force flatwise to the seating.

**Raccord d'accouplement pour rail
 de base PCB sur les cubes fonte
 minérale**

Avec ce raccord d'accouplement il est possible de rallonger le rail de base PCB avec un deuxième rail. A cause de l'adhérence on a la garantie que les pièces assemblées se comportent comme un rail continu. On a besoin d'une modification au bout des rails de base (fait par l'utilisateur). Des nouveaux rails de base peuvent être livré avec cette modification.

Ainsi les modules peuvent être placé entre les deux rails de bases. Une vis (B) additionnelle avec une rondelle-ressort absorbe la force perpendiculairement par la surface.

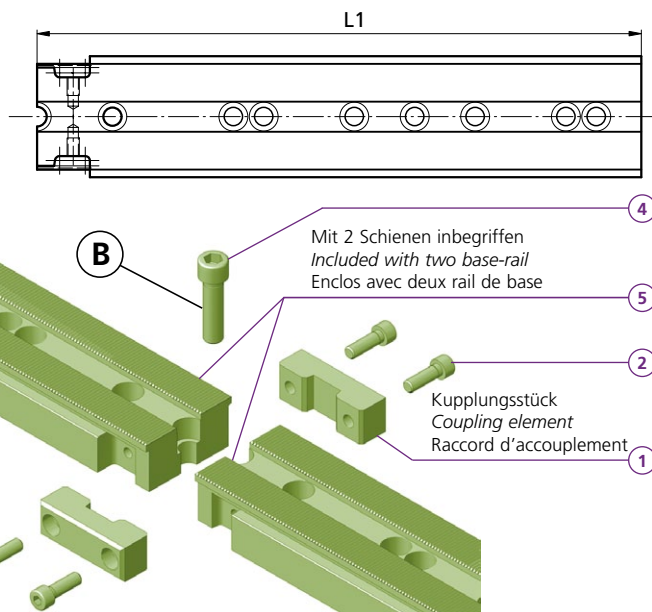
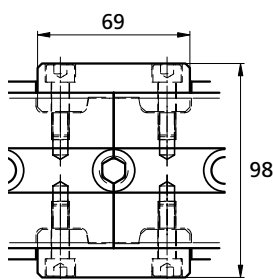
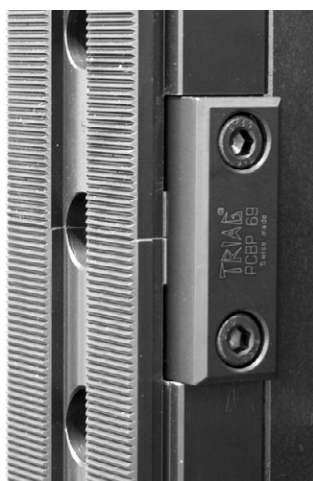

PCBP 69 SET	
1	2x TW090078
2	4x M8x25 ISO 4762
4	1x M12x45 ISO 4762
kg	~0,4

PCB 4050250KP	
L1	= 250
kg	~5,1

PCB 4050400KP	
L1	= 400
kg	~7,9

PCB 4050450KP	
L1	= 450
kg	~8,9

PCB 4050500KP	
L1	= 500
kg	~9,9

PCB 4050650KP	
L1	= 650
kg	~12,8

Bestellbeispiel / Ordering example / Exemple de commande: **PCB 4050250 KP**

Basis mit integrierter 0-Punkt Index Aufnahme oppSystem

Base rail with integrated oppSystem index

Base avec point 0 intégré et réception oppSysteme indexé

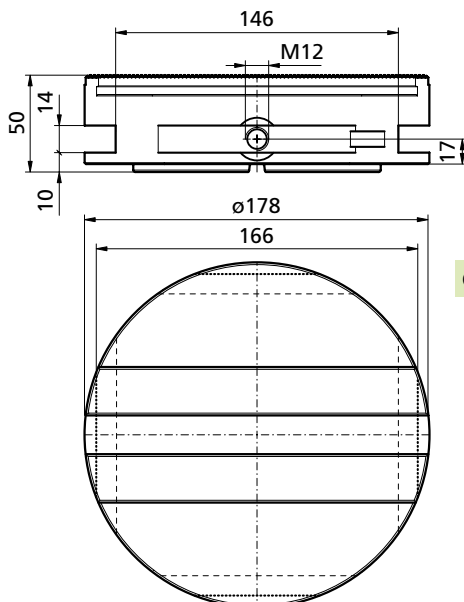

OPA 11D PCB D 178 kg ~7

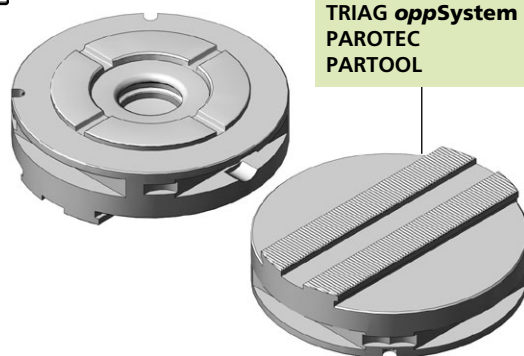
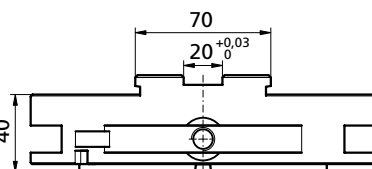

**TRIAG oppSystem
 PAROTEC
 PARTOOL**

Bestellbeispiel / Ordering example / Exemple de commande: **OPA 11D PCB 178**

Querschiene 90°
 Crossbar 90°
 Rail transversal 90°

PCB 250Q 90-H35



powerCLAMP

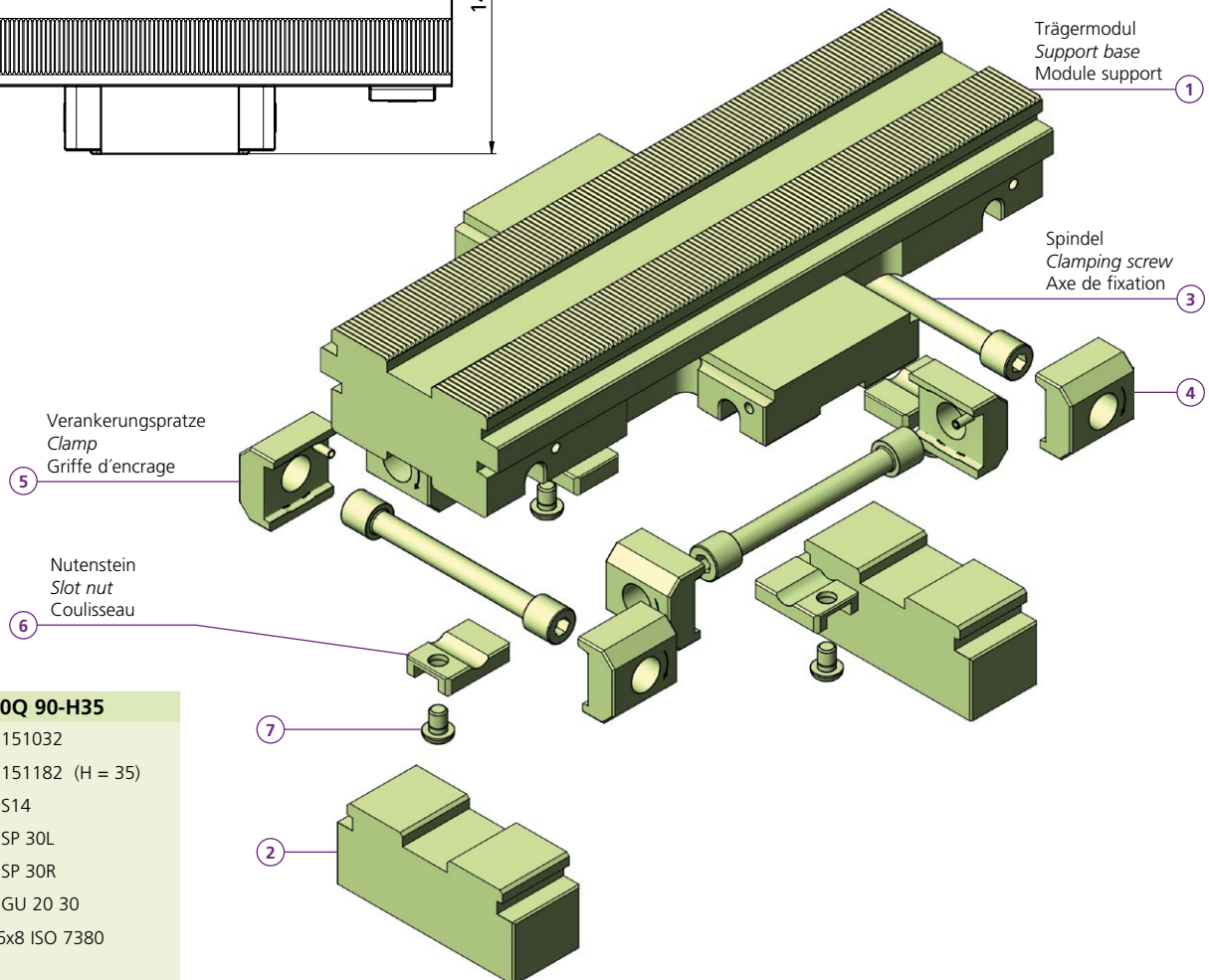
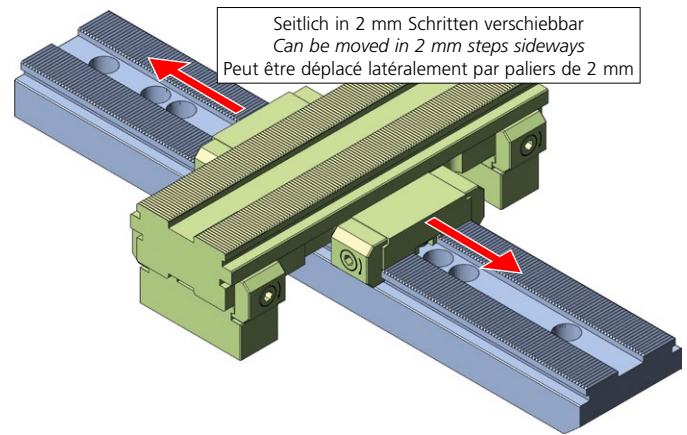
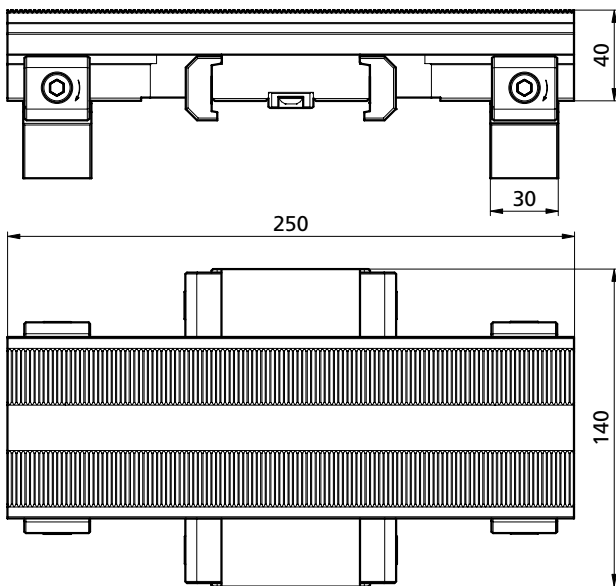
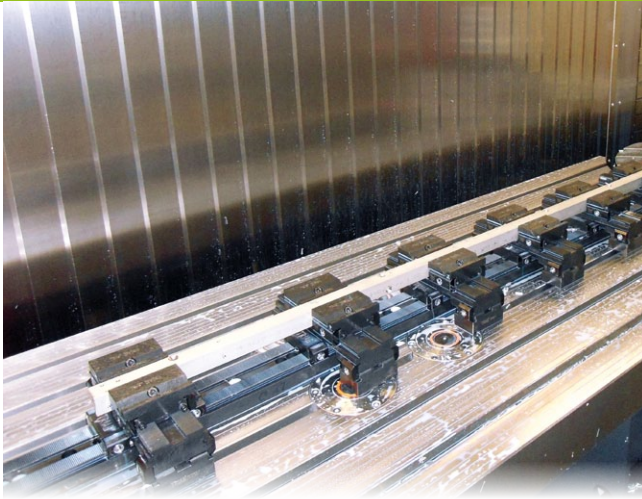

PCB 250Q 90-H35	
①	1x TH151032
②	2x TH151182 (H = 35)
③	4x PCS14
④	4x PCSP 30L
⑤	4x PCSP 30R
⑥	4x PCGU 20 30
⑦	1x M6x8 ISO 7380
kg	~8,18

Bestellbeispiel / Ordering example / Exemple de commande: PCB 250Q 90-H35

Separat bestellen / Separate order / Commander séparément

Erhöhung für 5-Achsenmaschinen PCUB 60-130

Riser for 5-axes machines

Rehaussement pour machine 5 axes

PCUB 100-200

PCUB 100-300 *powerCLAMP*

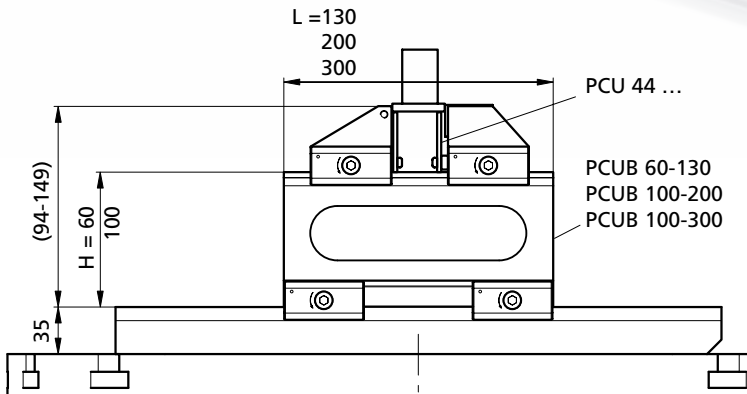
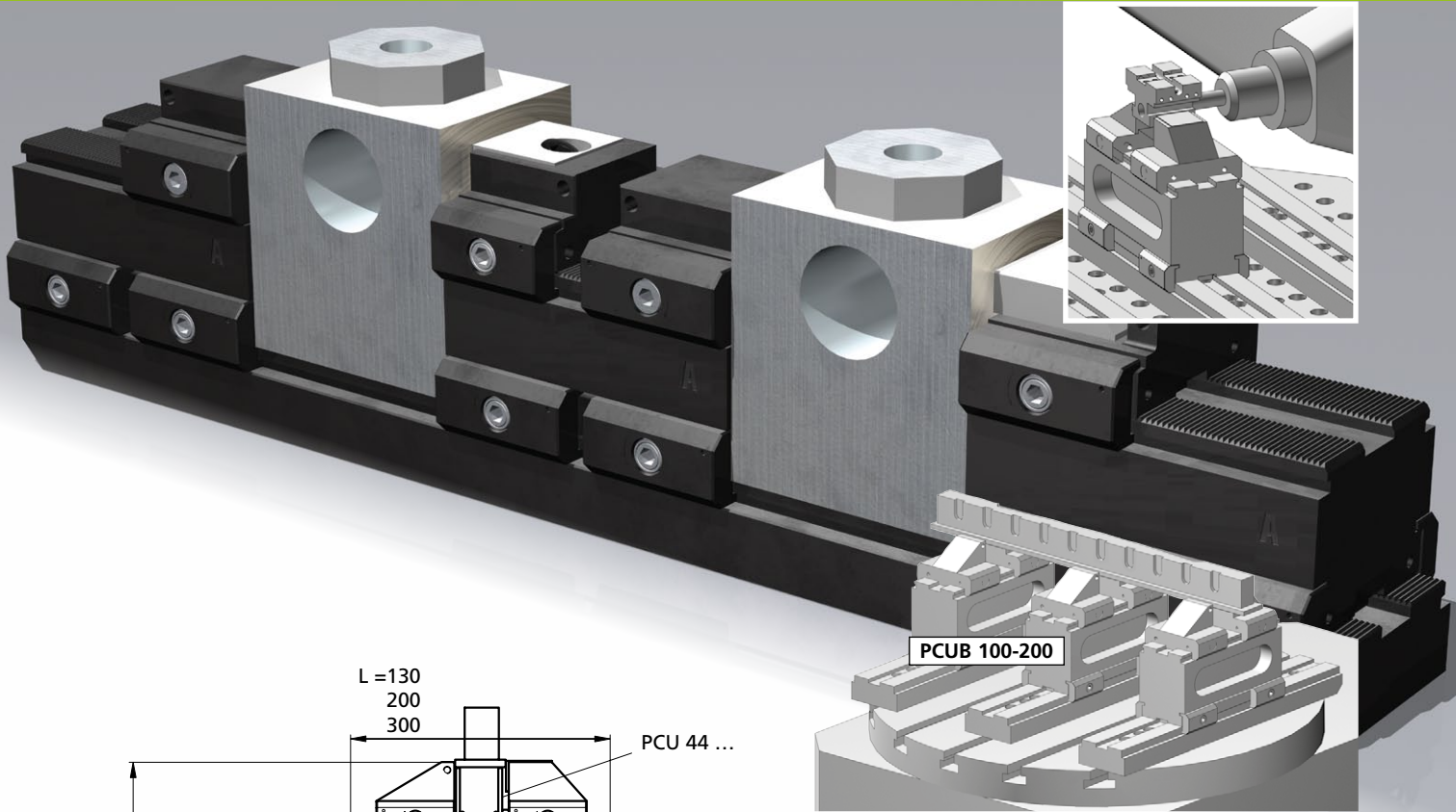

- | PCUB 60-130 | |
|--------------|------------------|
| 1 | 1x TK120596 |
| 3 | 2x PCSP 60R |
| 4 | 2x PCSP 60L |
| 5 | 2x PCS 14 |
| 6 | 2x PCGU 20 49 |
| 7 | 2x M6x8 ISO 7380 |
| L | = 130 |
| H | = 60 |
| kg | ~5,8 |
| PCUB 100-200 | |
| 1 | 1x TK130108 |
| L | = 200 |
| H | = 100 |
| kg | ~10,5 |
| PCUB 100-300 | |
| 1 | 1x TK130109 |
| 3 | 3x PCSP 60R |
| 4 | 3x PCSP 60L |
| 5 | 3x PCS 14 |
| 6 | 3x PCGU 20 49 |
| 7 | 3x M6x8 ISO 7380 |
| L | = 300 |
| H | = 100 |
| kg | ~16 |

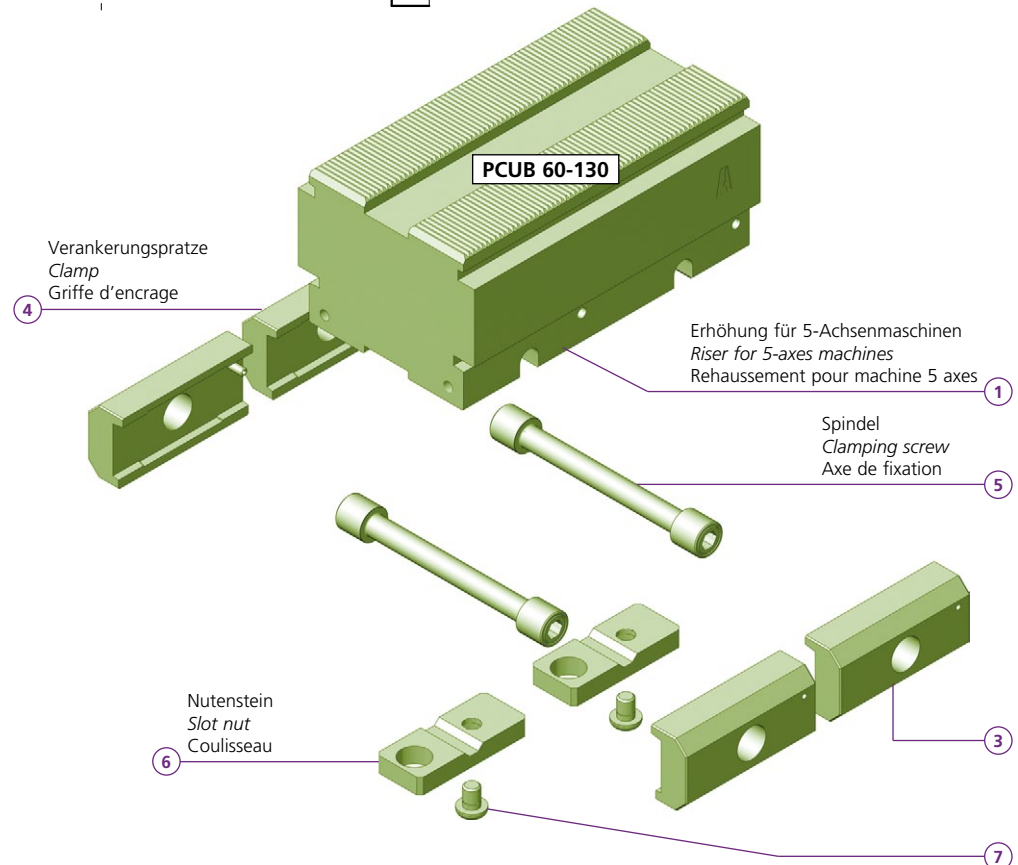

Bestellbeispiel / Ordering example / Exemple de commande: **PCUB 100-200**

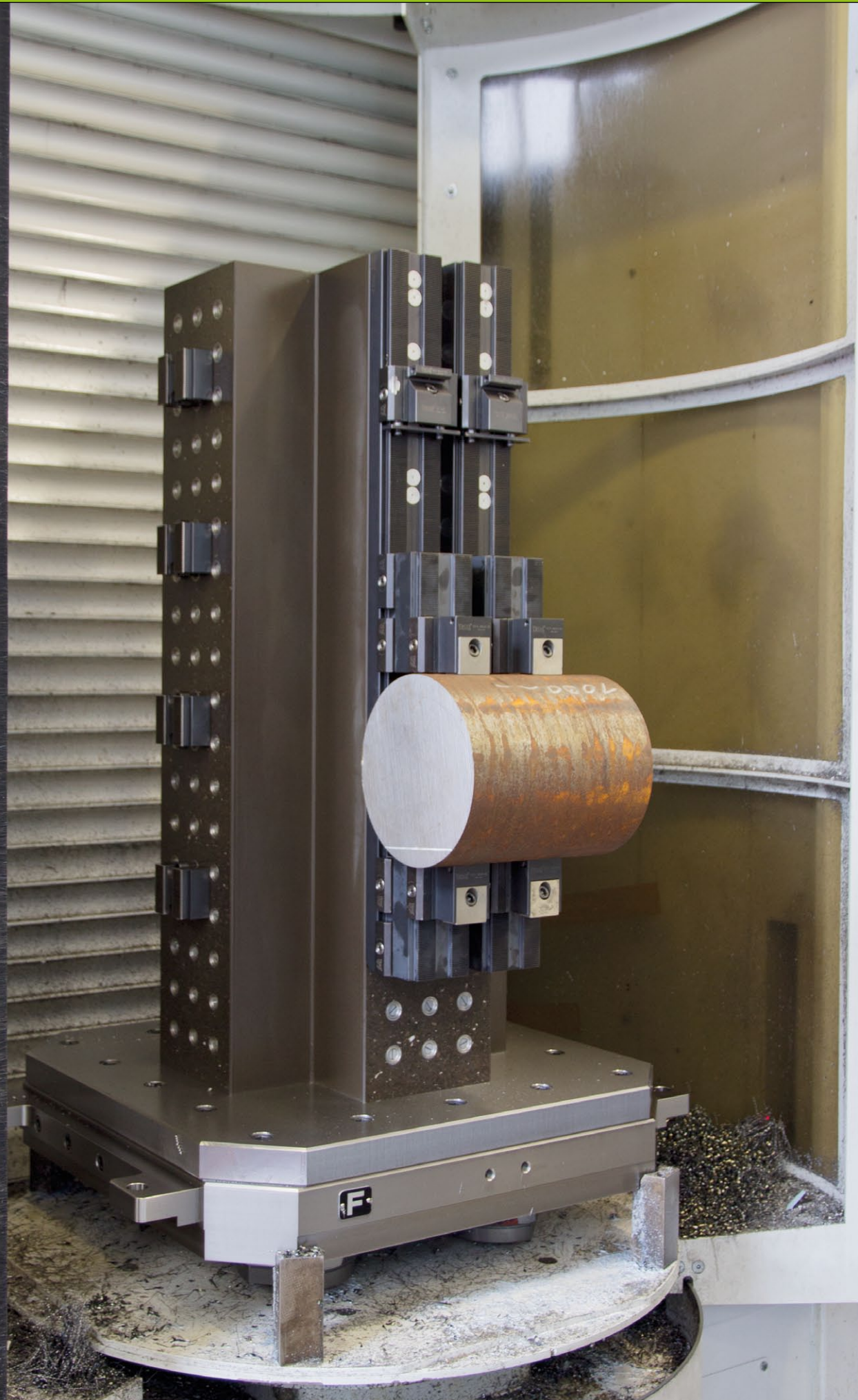



PCUB 115-200-R25
PCUB 115-300-R25

powerCLAMP

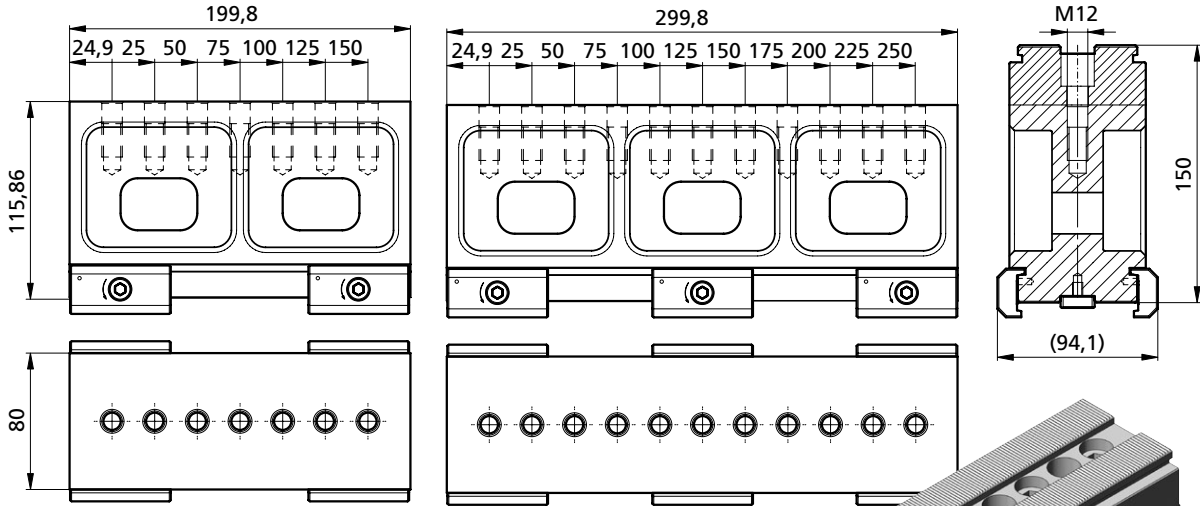

PCB 25-200 kg ~3,6

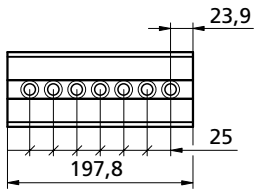

PCB 25-300 kg ~5,4

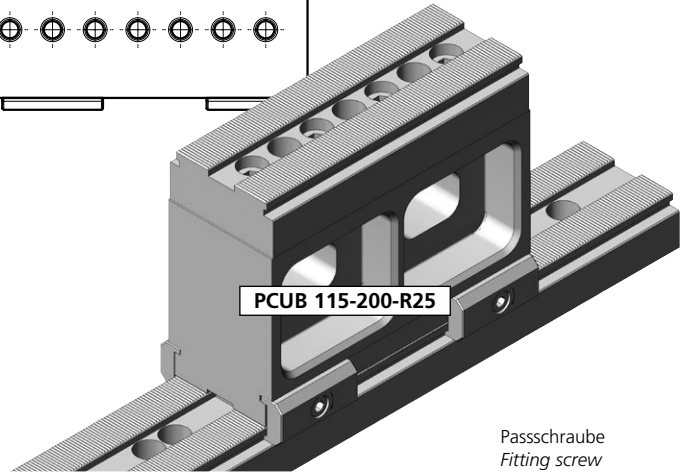
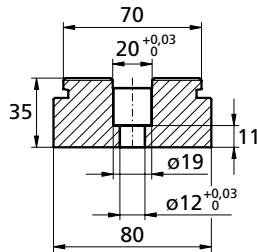
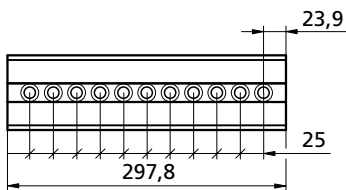

PCUB 115-200-R25

Passschraube
Fitting screw
Vis ajustée

9

Basisschiene
Base-rail
Rail de base

2

PCUB 115-200-R25

- 1 1x TK130323
- 2 1x PCB 25-200
- 3 2x PCSP 60R
- 4 2x PCSP 60L
- 5 2x PCS 14
- 6 2x PCGU 20 49
- 7 2x M6x8 ISO 7380
- 9 2x TWPAS 1240
- 10 2x M12x40 ISO 4762

kg ~13

PCUB 115-300-R25

- 1 1x TK130324
- 2 1x PCB 25-300
- 3 3x PCSP 60R
- 4 3x PCSP 60L
- 5 3x PCS 14
- 6 3x PCGU 20 49
- 7 3x M6x8 ISO 7380
- 9 2x TWPAS 1240
- 10 4x M12x40 ISO 4762

kg ~19,6

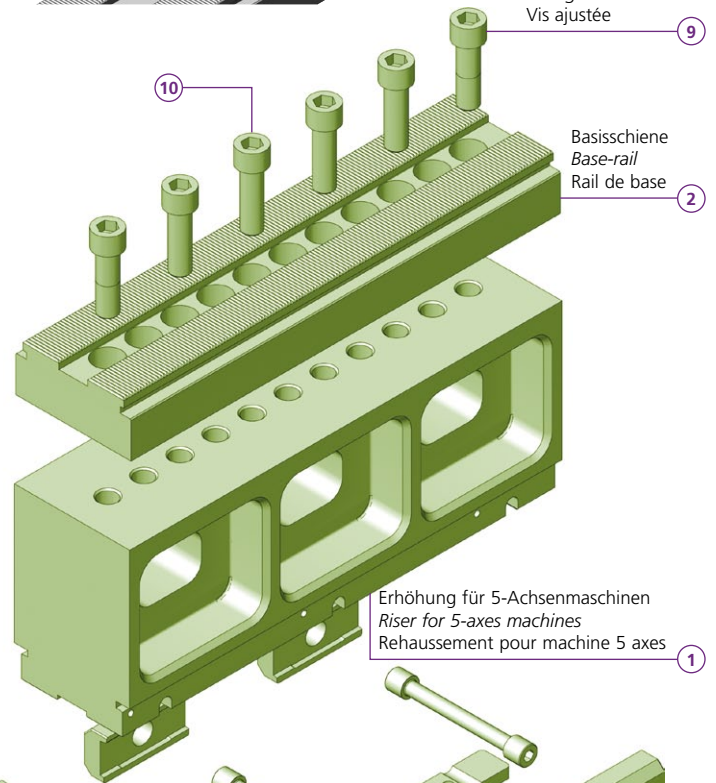

Erhöhung für 5-Achsenmaschinen
Riser for 5-axes machines
Rehaussement pour machine 5 axes

1

Verankerungspratze
Clamp
Griffe d'encrage

4

Spindel
Clamping screw
Axe de fixation

5

Nutenstein
Slot nut
Coulisseau

6

3

7

Bestellbeispiel / Ordering example / Exemple de commande: PCUB 115-300-R25



- Zentrischspanner / *self centring vise* / auto-centrage étau
- 0-Punktplatten / *Zero point system* / système de point zéro
- Power Clamp Basisschienen / *Power Clamp base rails* / Power Clamp rail de base
- Sondervorrichtungen / *Dedicated fixtures* / Dispositifs spéciaux

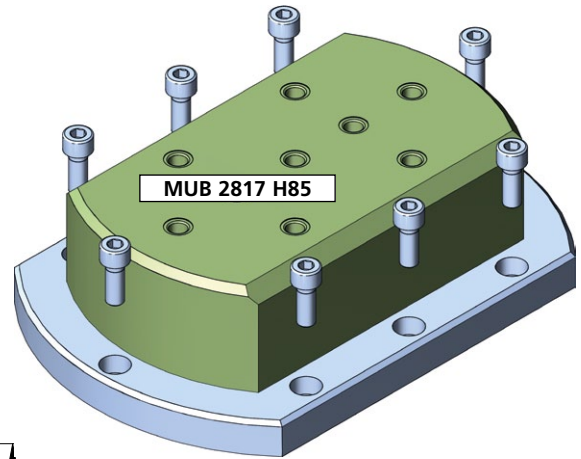
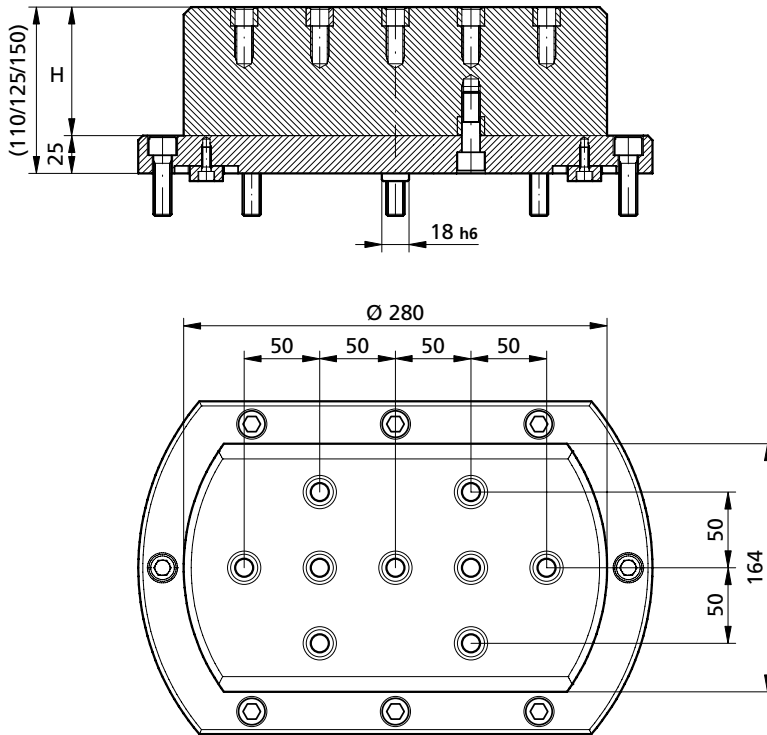

Bestellnummer Order number	Abmessung Dimension	
	H	kg
MUB 2817 H85	85	~10
MUB 2817 H100	100	~12
MUB 2817 H125	125	~15



Bestellbeispiel / *Ordering example* / Exemple de commande: MUB 2817 H85



- Vorteil vibrationshemmend / *Damping is a big advantage* / Le bénéfice, il est résistant aux vibrations
- 3 Bauhöhen standard / *3 different heights are standard* / 3 hauteurs différentes sont standard
- Universell / *Flexibility* / Universel

- kann Vorrichtungen aufnehmen
can adapt fixture plates
peut adapter dispositif
- kann Power Clamp Basisschienen aufnehmen
can adapt PCB base rails
peut adapter PCB rail de base
- kann Zentrischspanner aufnehmen
can adapt self centring vise
peut adapter auto-centrage étau

Basisschiene - Base-rail - Rail de base

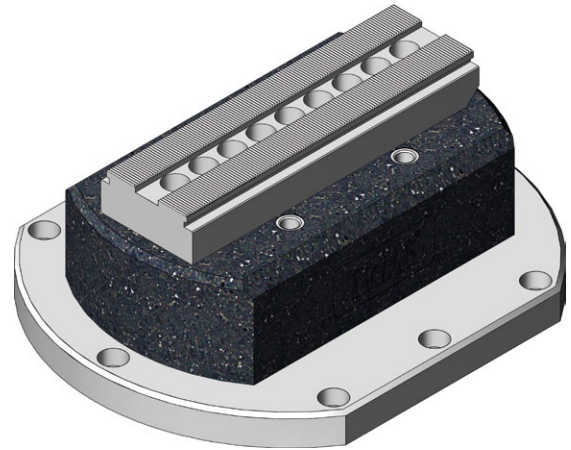

Zentrischspanner - Self centring vise - Module à centrer

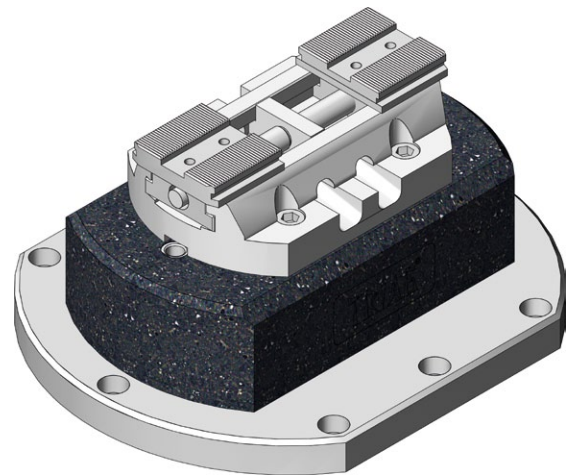

Hilfreiches Zubehör für grosse Tische
Take out accessories for large tables
Accessoires utiles pour les grandes tables

- Power Clamp Basisschienen in diversen Längen & Höhen
Base rails in different length & height
Rails de base de différentes longueurs et hauteurs
- Erhöhung in verschiedenen Variationen und Höhen
Riser blocks in different heights & length
Rails de base de différentes variantes et hauteurs
- Über 200 verschiedene Spanmodule sind erhältlich
More than 200 different clamp modules
Plus de 200 différents modules de serrage

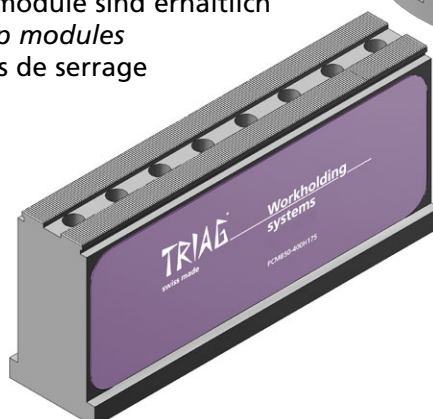
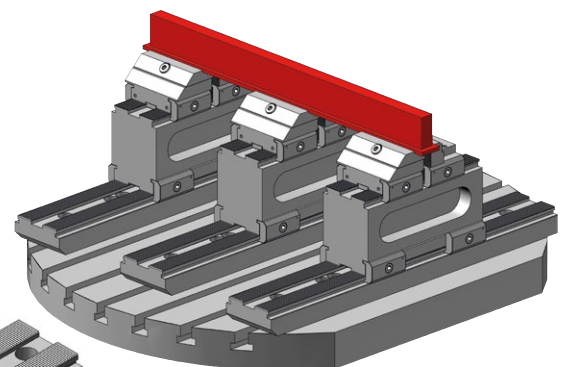

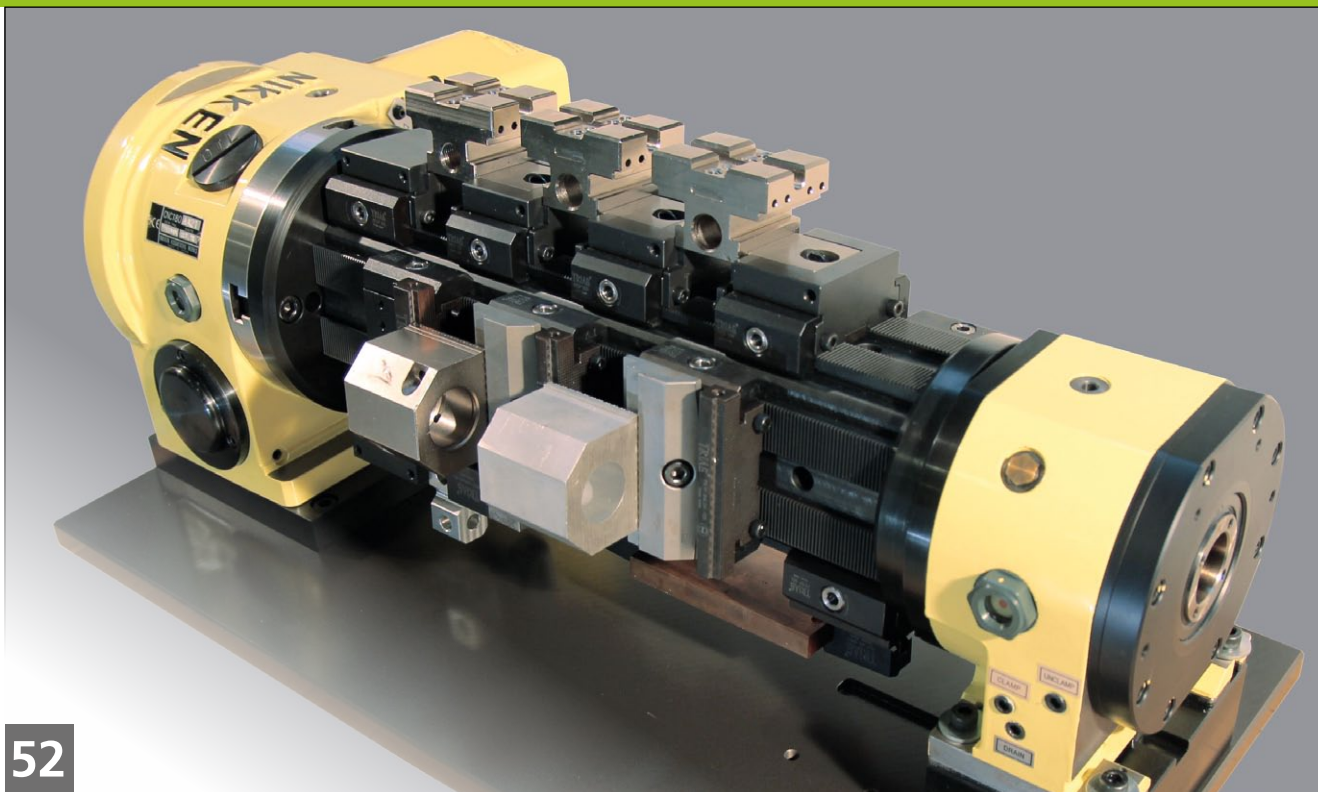

52

Teilapparat / PC Monobloc
 Indexing device / PC Monobloc
 Diviseur / PC Monobloc

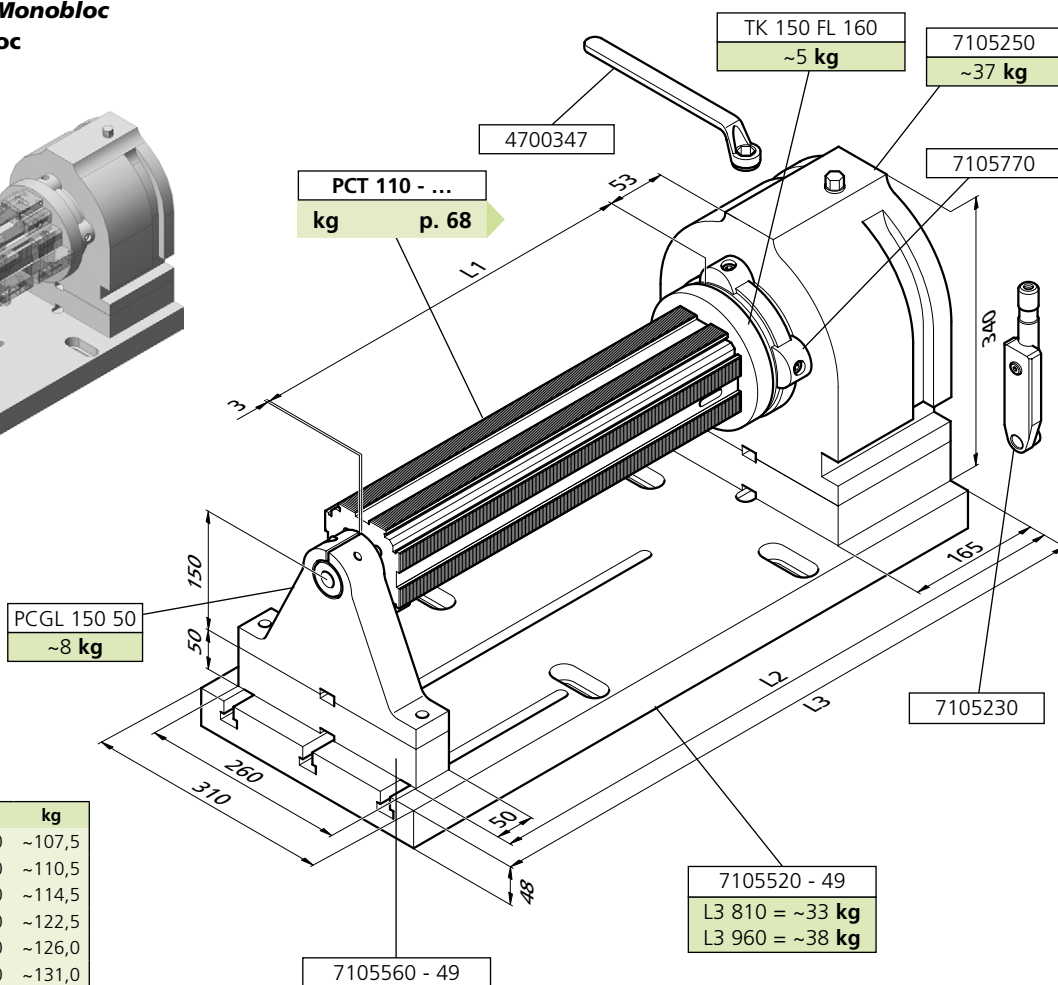
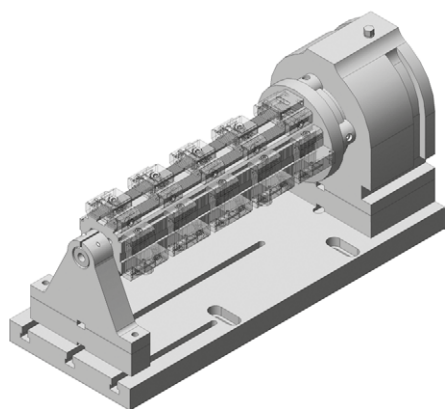

	L1	L2	L3	kg
TKPC 110 - 300	582	810		~107,5
TKPC 110 - 350	632	810		~110,5
TKPC 110 - 400	682	810		~114,5
TKPC 110 - 450	732	810		~122,5
TKPC 110 - 500	782	810		~126,0
* TKPC 110 - 550	832	960		~131,0
* TKPC 110 - 600	882	960		~135,0
* TKPC 110 - 650	932	960		~139,0

* Entspricht nicht der Abbildung
 Does not correspond to the illustration
 Ne correspond pas à l'illustration

Bestellbeispiel / Ordering example / Exemple de commande: **TKPC 110-300**



	L	kg	Ø D			
PCT 110- TF140663	300	~24,5	255	241	211	224
PCT 110- TF140664	350	~27,5	255	241	211	224
PCT 110- TF140665	400	~31,5	255	241	211	224
PCT 110- TF140666	450	~35,5	255	241	211	224
PCT 110- TF140667	500	~39,5	255	241	211	224
PCT 110- TF140668	550	~43,0	255	241	211	224
PCT 110- TF140669	600	~47,0	255	241	211	224
PCT 110- TF140670	650	~51,0	255	241	211	224

	L	kg	Ø D			
PCMT 150- ZB140756	700	~83	238	266	278	
PCMT 150- ZB140288	750	~89	238	266	278	
PCMT 150- ZB140290	800	~95	238	266	278	
PCMT 150- ZB140280	850	~101	238	266	278	

PS1R 43N49 B60
 PS1R 94N34 B80
 PS1R 94N49 B90
 PS1R 125N49 B95

Monobloc powerCLAMP 110 x 110 x ...

40 h6

- 2x TWPAS 1240
- 2x M12x40
- 1x PCTBO 40100
- 1x M10x100 ISO 4762

øD

Bestellbeispiel / Ordering example / Exemple de commande: PCT 110-500

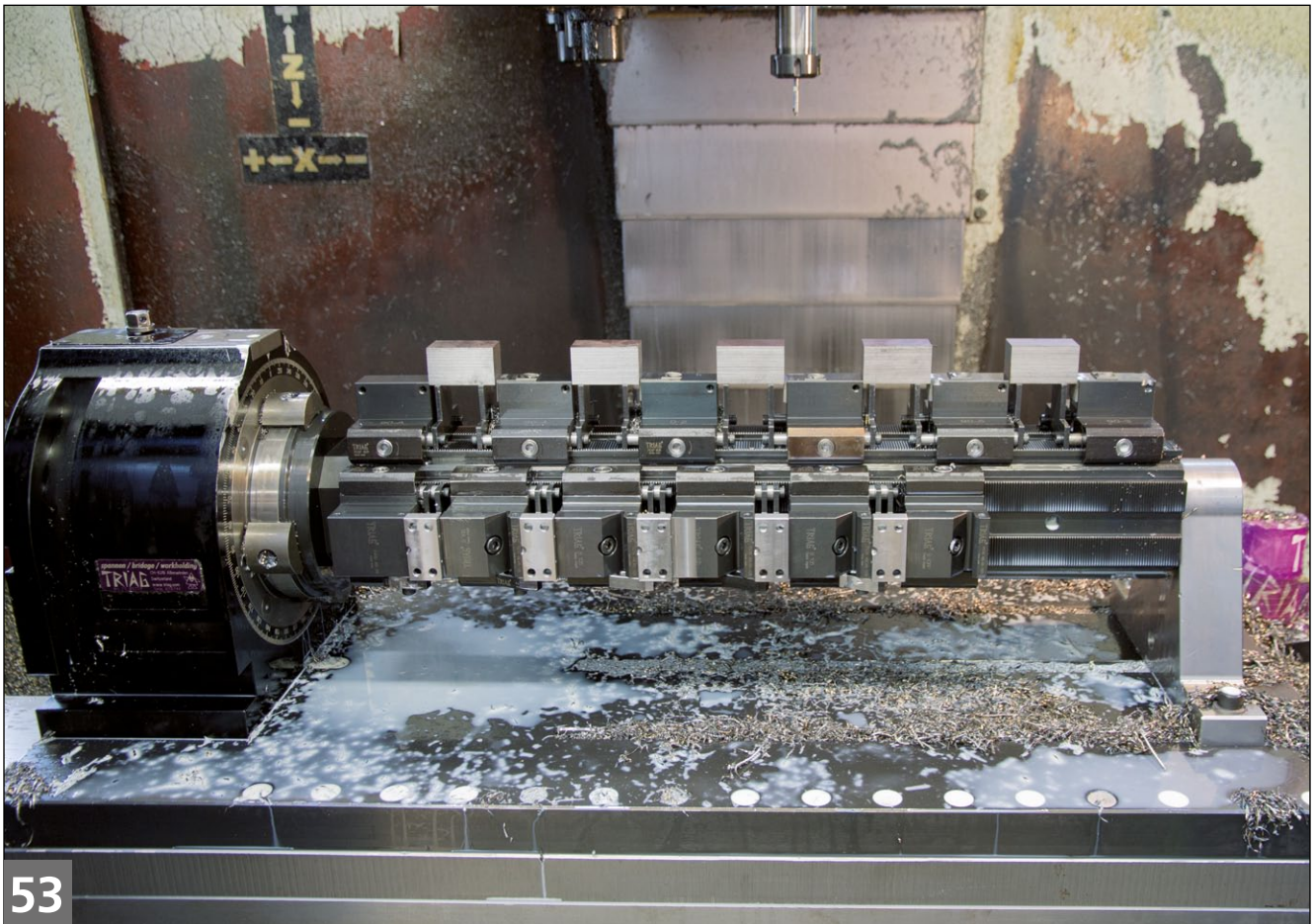

Spannturm zu Matsuura
 Tombestone for Matsuura
 Tourelle de serrage pour Matsuura



powerCLAMP

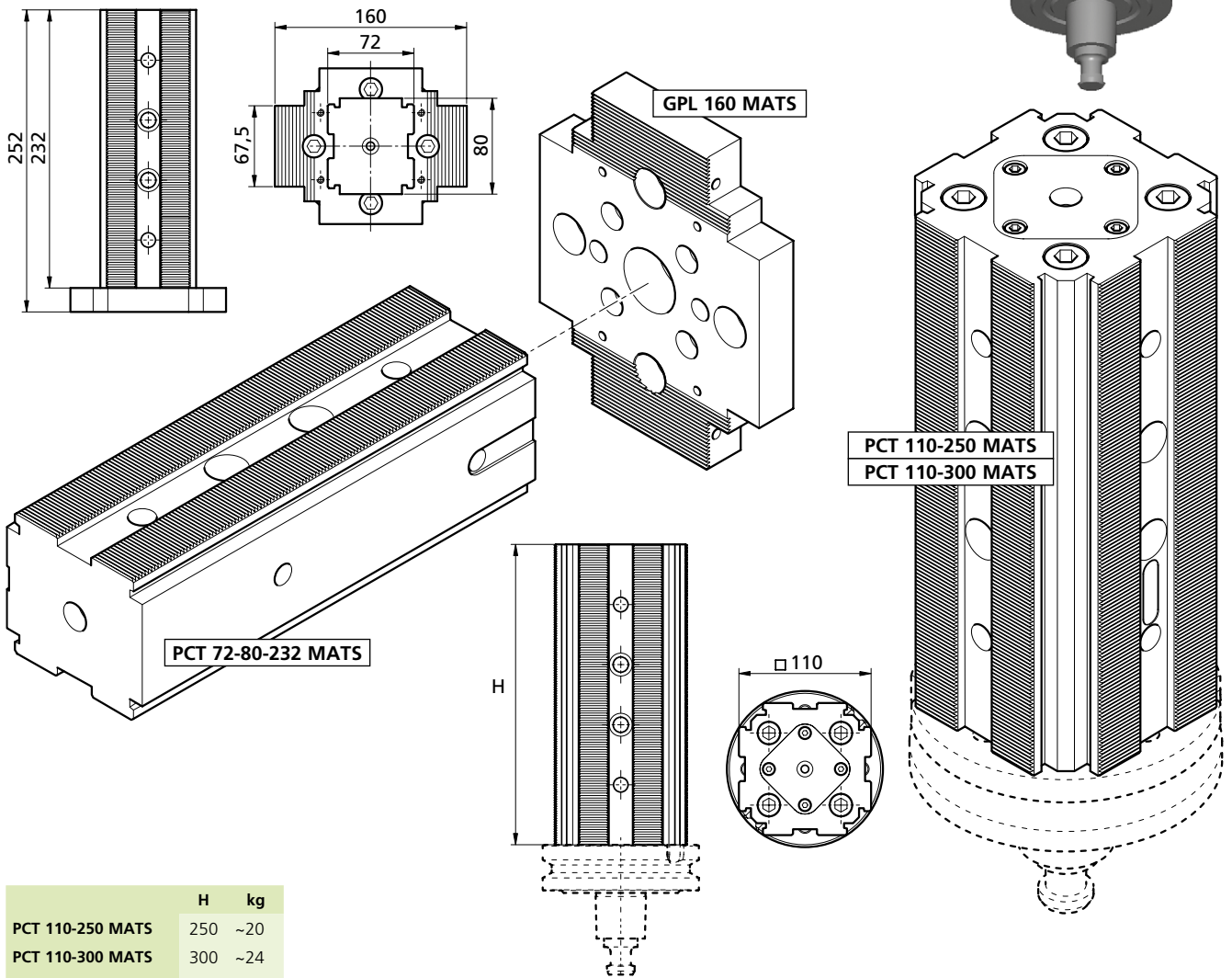
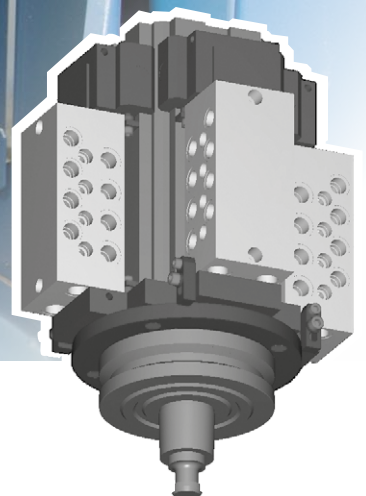
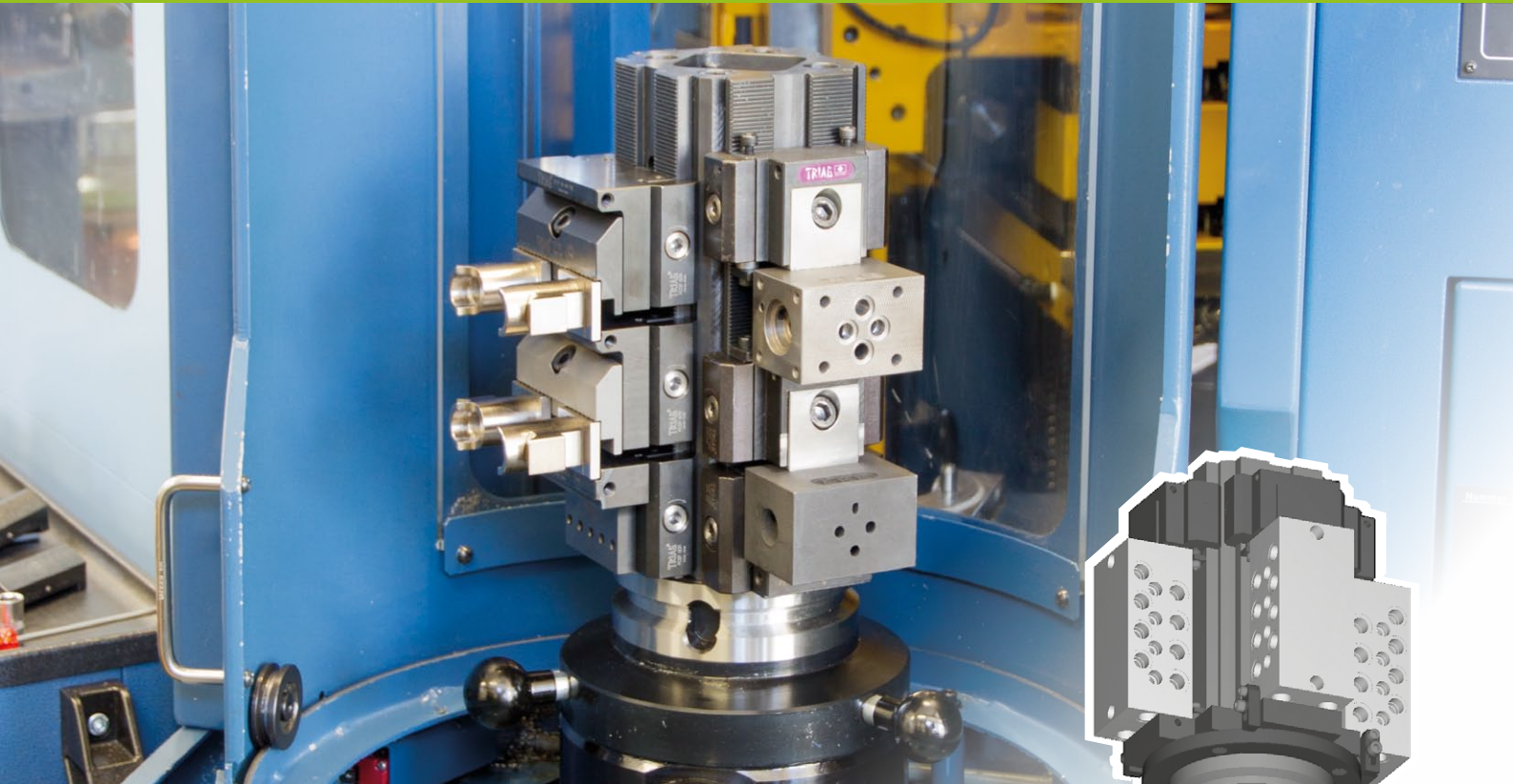

	H	kg
PCT 110-250 MATS	250	~20
PCT 110-300 MATS	300	~24
PCT 72-80-232 MATS	232	~11
GPL 160 MATS	20	~2,2

Bestellbeispiel / Ordering example / Exemple de commande: **PCT 110-250 MATS**

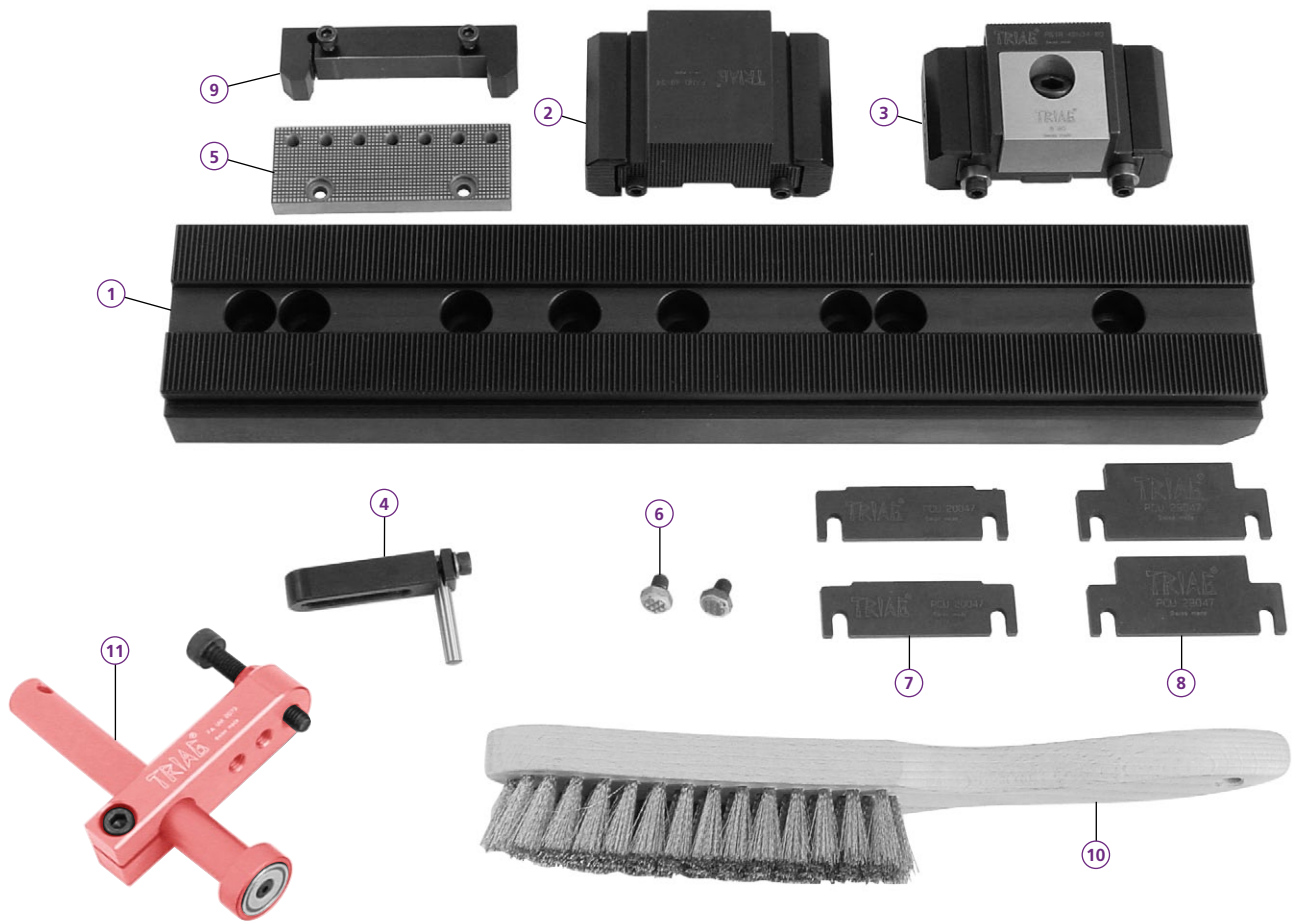

Bestellbeispiel / Ordering example / Exemple de commande: 400 PC-SET 48 AJ-2

Länge der Basisschiene
Length of base rail
Longueur du rail de base

Anzahl Spannstellen
Number of clamping stations
Quantité de stations de serrage

Basisschiene Base rail Rail de base	Spannmodul Clamping module Module de serrage	Anschlagbacke End jaw Plaque d'appui	Parallelunterlagen Steel parallels Cales parallèles	Unterlagenhalter Base holder Support pour cales parallèles	Magnetfränschlag Magnet milling buffer Buttée de fraisage avec aimant
PCB4050...	PS1R 48N34 B80	PC 9434 RF	PCU 20047	PCUH 2594	FAUM 2070
Anschlagmodul End module Module d'appui PAND 48-34	Fränschlag Milling buffer Buttée de fraisage FA 1260	Hartmetalldruckstück Hardmetal thrust piece Pièce de pression CCHMR	Parallelunterlagen Steel parallels Cales parallèles PCU 29047	Messingbürste Brass brush Brosse en laiton PCMB 4	

	L	N	1	2	3	4	5	6	7	8	9	10	11
400 PC-SET 48 AJ-1	400 mm	1	1x	1x	1x	1x	1x	2x	2x	2x	2x	1x	1x
400 PC-SET 48 AJ-2	400 mm	2	1x	1x	2x	2x	2x	4x	4x	4x	4x	1x	1x
400 PC-SET 48 AJ-3	400 mm	3	1x	1x	3x	3x	3x	6x	6x	6x	6x	1x	1x
450 PC-SET 48 AJ-1	450 mm	1	1x	1x	1x	1x	1x	2x	2x	2x	2x	1x	1x
450 PC-SET 48 AJ-2	450 mm	2	1x	1x	2x	2x	2x	4x	4x	4x	4x	1x	1x
450 PC-SET 48 AJ-3	450 mm	3	1x	1x	3x	3x	3x	6x	6x	6x	6x	1x	1x
500 PC-SET 48 AJ-1	500 mm	1	1x	1x	1x	1x	1x	2x	2x	2x	2x	1x	1x
500 PC-SET 48 AJ-2	500 mm	2	1x	1x	2x	2x	2x	4x	4x	4x	4x	1x	1x
500 PC-SET 48 AJ-3	500 mm	3	1x	1x	3x	3x	3x	6x	6x	6x	6x	1x	1x
550 PC-SET 48 AJ-1	550 mm	1	1x	1x	1x	1x	1x	2x	2x	2x	2x	1x	1x
550 PC-SET 48 AJ-2	550 mm	2	1x	1x	2x	2x	2x	4x	4x	4x	4x	1x	1x
550 PC-SET 48 AJ-3	550 mm	3	1x	1x	3x	3x	3x	6x	6x	6x	6x	1x	1x
600 PC-SET 48 AJ-1	600 mm	1	1x	1x	1x	1x	1x	2x	2x	2x	2x	1x	1x
600 PC-SET 48 AJ-2	600 mm	2	1x	1x	2x	2x	2x	4x	4x	4x	4x	1x	1x
600 PC-SET 48 AJ-3	600 mm	3	1x	1x	3x	3x	3x	6x	6x	6x	6x	1x	1x
650 PC-SET 48 AJ-1	650 mm	1	1x	1x	1x	1x	1x	2x	2x	2x	2x	1x	1x
650 PC-SET 48 AJ-2	650 mm	2	1x	1x	2x	2x	2x	4x	4x	4x	4x	1x	1x
650 PC-SET 48 AJ-3	650 mm	3	1x	1x	3x	3x	3x	6x	6x	6x	6x	1x	1x



PC Set 1/2/3 A ...

A	PC SET 1A 450	A	PC SET 2A 550	A	PC SET 3A 650
1 x	PCB 40-50-450	1 x	PCB 40-50-550	1 x	PCB 40-50-650
4 x	PS1 R94 N34B80	5 x	PS1 R94 N34B80	6 x	PS1 R94 N34B80
1 x	PAND 94 - 34	1 x	PAND 94 - 34	1 x	PAND 94 - 34
8 x	PCU 20093	10 x	PCU 20093	12 x	PCU 20093
8 x	PCU 29093	10 x	PCU 29093	12 x	PCU 29093
4 x	FA 1240	5 x	FA 1240	6 x	FA 1240
A	PC SET 1A 500	A	PC SET 2A 600		
1 x	PCB 40-50-500	1 x	PCB 40-50-600		
4 x	PS1 R94 N34B80	5 x	PS1 R94 N34B80		
1 x	PAND 94 - 34	1 x	PAND 94 - 34		
8 x	PCU 20093	10 x	PCU 20093		
8 x	PCU 29093	10 x	PCU 29093		
4 x	FA 1240	5 x	FA 1240		

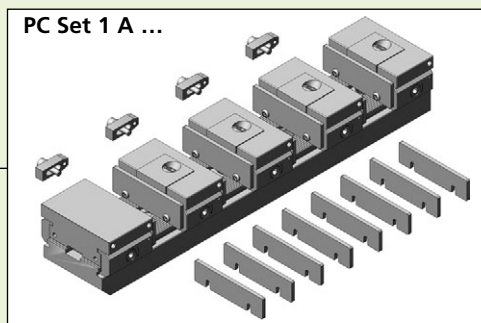

PC Set 1/2/3 B ...

B	PC SET 1B 450	B	PC SET 2B 550	B	PC SET 3B 650
1 x	PCB 40-50-450	1 x	PCB 40-50-550	1 x	PCB 40-50-650
4 x	PS1 R94 N34B90	5 x	PS1 R94 N34B90	6 x	PS1 R94 N34B90
1 x	PAND 94 - 34	1 x	PAND 94 - 34	1 x	PAND 94 - 34
8 x	PCU 20093	10 x	PCU 20093	12 x	PCU 20093
8 x	PCU 29093	10 x	PCU 29093	12 x	PCU 29093
4 x	FA 1240	5 x	FA 1240	6 x	FA 1240
B	PC SET 1B 500	B	PC SET 2B 600		
1 x	PCB 40-50-500	1 x	PCB 40-50-600		
4 x	PS1 R94 N34B90	5 x	PS1 R94 N34B90		
1 x	PAND 94 - 34	1 x	PAND 94 - 34		
8 x	PCU 20093	10 x	PCU 20093		
8 x	PCU 29093	10 x	PCU 29093		
4 x	FA 1240	5 x	FA 1240		

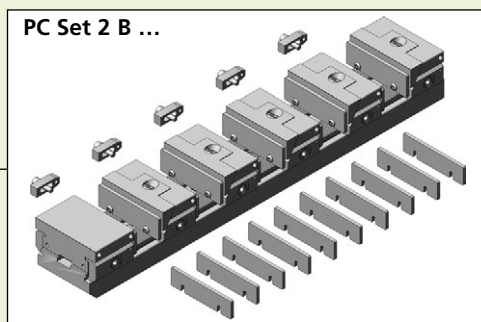

PC Set 1/2/3 C ...

C	PC SET 1C 450	C	PC SET 2C 550	C	PC SET 3C 650
1 x	PCB 40-50-450	1 x	PCB 40-50-550	1 x	PCB 40-50-650
4 x	PS1 R48 N34B80	5 x	PS1 R48 N34B80	6 x	PS1 R48 N34B80
1 x	PAND 48 - 34	1 x	PAND 48 - 34	1 x	PAND 48 - 34
8 x	PCU 20047	10 x	PCU 20047	12 x	PCU 20047
8 x	PCU 29047	10 x	PCU 29047	12 x	PCU 29047
4 x	FA 1240	5 x	FA 1240	6 x	FA 1240
C	PC SET 1C 500	C	PC SET 2C 600		
1 x	PCB 40-50-500	1 x	PCB 40-50-600		
4 x	PS1 R48 N34B80	5 x	PS1 R48 N34B80		
1 x	PAND 48 - 34	1 x	PAND 48 - 34		
8 x	PCU 2004A7	10 x	PCU 20047		
8 x	PCU 29047	10 x	PCU 29047		
4 x	FA 1240	5 x	FA 1240		

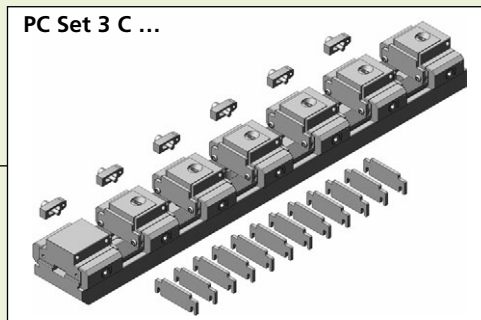



PC Präge-Set 3/4/5 D ...

D	PC SET 3D 450	D	PC SET 3D 500	D	PC SET 4D 550	D	PC SET 4D 600	D	PC SET 5D 650
1 x	PCB 40-50-450	1 x	PCB 40-50-500	1 x	PCB 40-50-550	1 x	PCB 40-50-600	1 x	PCB 40-50-650
3 x	PS1 P94L34 B120P	3 x	PS1 P94L34B120P	4 x	PS1 P94L34 B120P	4 x	PS1 P94L34 B120P	5 x	PS1 P94L34 B120P
1 x	PAND 94-34 PRG-A1	1 x	PAND 94-34 PRG-A1	1 x	PAND 94-34 PRG-A1	1 x	PAND 94-34 PRG-A1	1 x	PAND 94-34 PRG-A1
6 x	PCU 24093	6 x	PCU 24093	8 x	PCU 24093	8 x	PCU 24093	10 x	PCU 24093
1 x	FAUM 2070	1 x	FAUM 2070	1 x	FAUM 2070	1 x	FAUM 2070	1 x	FAUM 2070

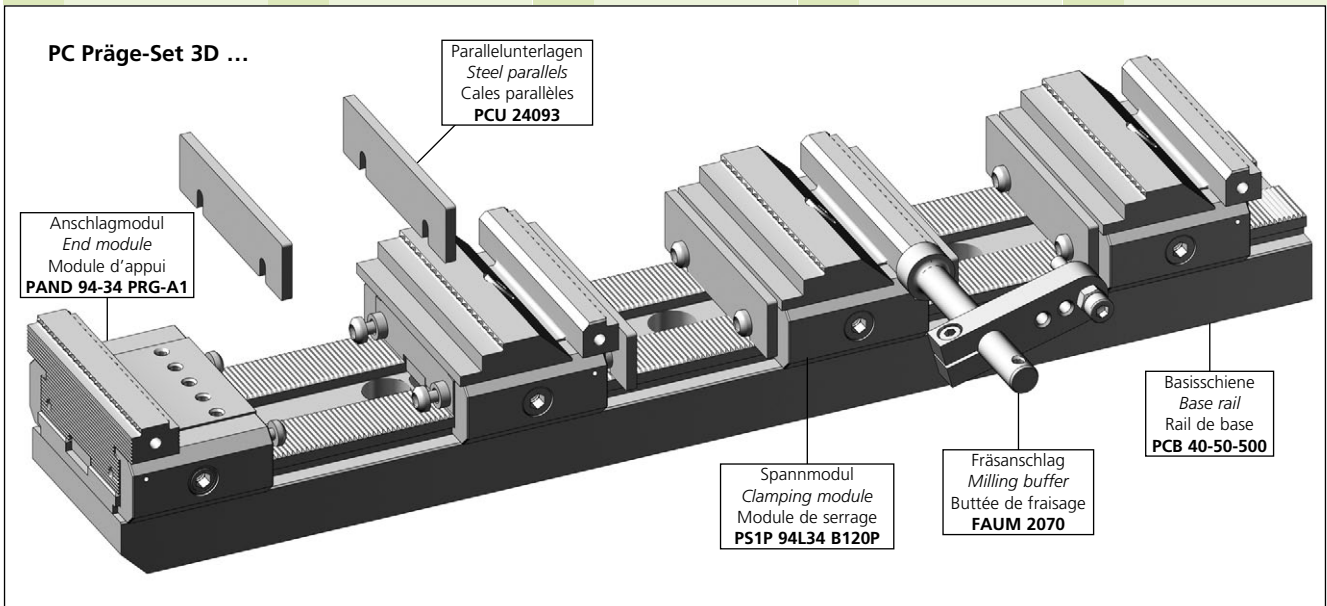

PC Linear-Set 3/4/5 E ...

E	PC SET 3E 450	E	PC SET 3E 500	E	PC SET 4E 550	E	PC SET 4E 600	E	PC SET 5E 650
1 x	PCB 40-50-450	1 x	PCB 40-50-500	1 x	PCB 40-50-550	1 x	PCB 40-50-600	1 x	PCB 40-50-650
3 x	PS1 R48L34 B105	3 x	PS1 R48L34 B105	4 x	PS1 R48L34 B105	4 x	PS1 R48L34 B105	5 x	PS1 R48L34 B105
1 x	PAND 48-34	1 x	PAND 48-34	1 x	PAND 48-34	1 x	PAND 48-34	1 x	PAND 48-34
6 x	PCU 20047	6 x	PCU 20047	8 x	PCU 20047	8 x	PCU 20047	10 x	PCU 20047
6 x	PCU 29047	6 x	PCU 29047	8 x	PCU 29047	8 x	PCU 29047	10 x	PCU 29047
3 x	FA 1240	3 x	FA 1240	4 x	FA 1240	4 x	FA 1240	5 x	FA 1240

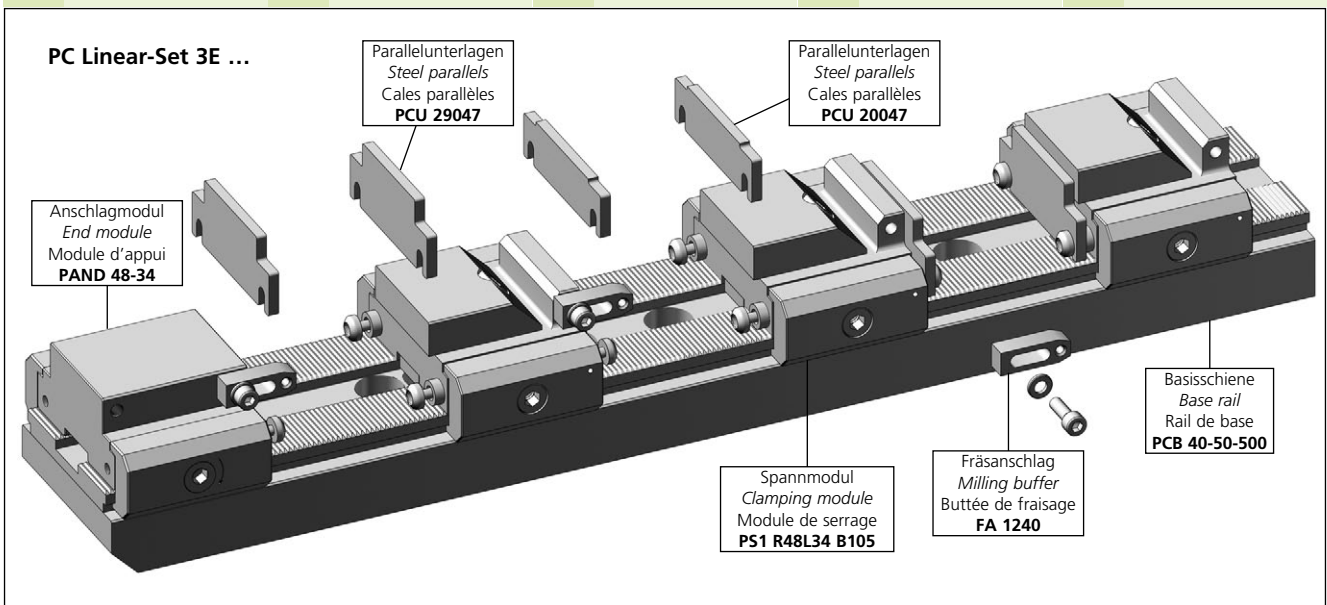



	L	N	1	2	3	4	5	6	7	8	9	10	11	12	13	14	15	
	690mm	2x	1x	1x	1x	1x	1x	1x	1x	2x	4x	4x	4x	4x	2x	2x	1x	1x
Hurco 690PC-SET48AJ-2	690mm	4x	2x	2x	2x	2x	2x	2x	2x	4x	8x	8x	8x	8x	4x	4x	1x	1x
Hurco 690PC-SET48AJ-4	690mm	4x	2x	2x	2x	2x	2x	2x	2x	4x	8x	8x	8x	8x	4x	4x	1x	1x

Anzahl Spannstellen
 Number of clamping stations
 Quantité de stations de serrage

Länge der Basisschiene
 Length of base rail
 Longueur du rail de base

- Basisschiene / Base rail / Rail de base
PCB100690H60
- Anschlagmodul / End module / Module d'appui
PAND48-34
- Spannmodul / Clamping module / Module de serrage
PS1R48N34B80 (Niederzug / Pull down / Descendent)
- Spannmodul / Clamping module / Module de serrage
PS1R48L34B105 (Linear / linear / linéaire)
- Anschlagbacke / End jaw / Plaque d'appui
PC9434 RF (Universal / universal / universel)
- Spannbacke / Clamping jaw / Mors du serrage
B 110 (Linear / Linear / Linéaire)
- Fräsanschlag / Milling buffer / Butée de fraisage
FA 1260
- Parallelunterlagen / Steel parallels / Cales parallèles
PCU 20047
- Parallelunterlagen / Steel parallels / Cales parallèles
PCU 31047
- Parallelunterlagen / Steel parallels / Cales parallèles
PCU 24047
- Parallelunterlagen / Steel parallels / Cales parallèles
PCU 29047
- Unterlagenhalter / Base holder
PCUH 2594 Support pour cales parallèles
- Hartmetalldruckstück / Magnet milling buffer
CCHMR Buttée de fraisage avec aimant
- Magnetfräsansschlag / Magnet milling buffer
FAUM 2070 Buttée de fraisage avec aimant
- Messingbürste / Brass brush / Brosse en laiton
PCMB 4

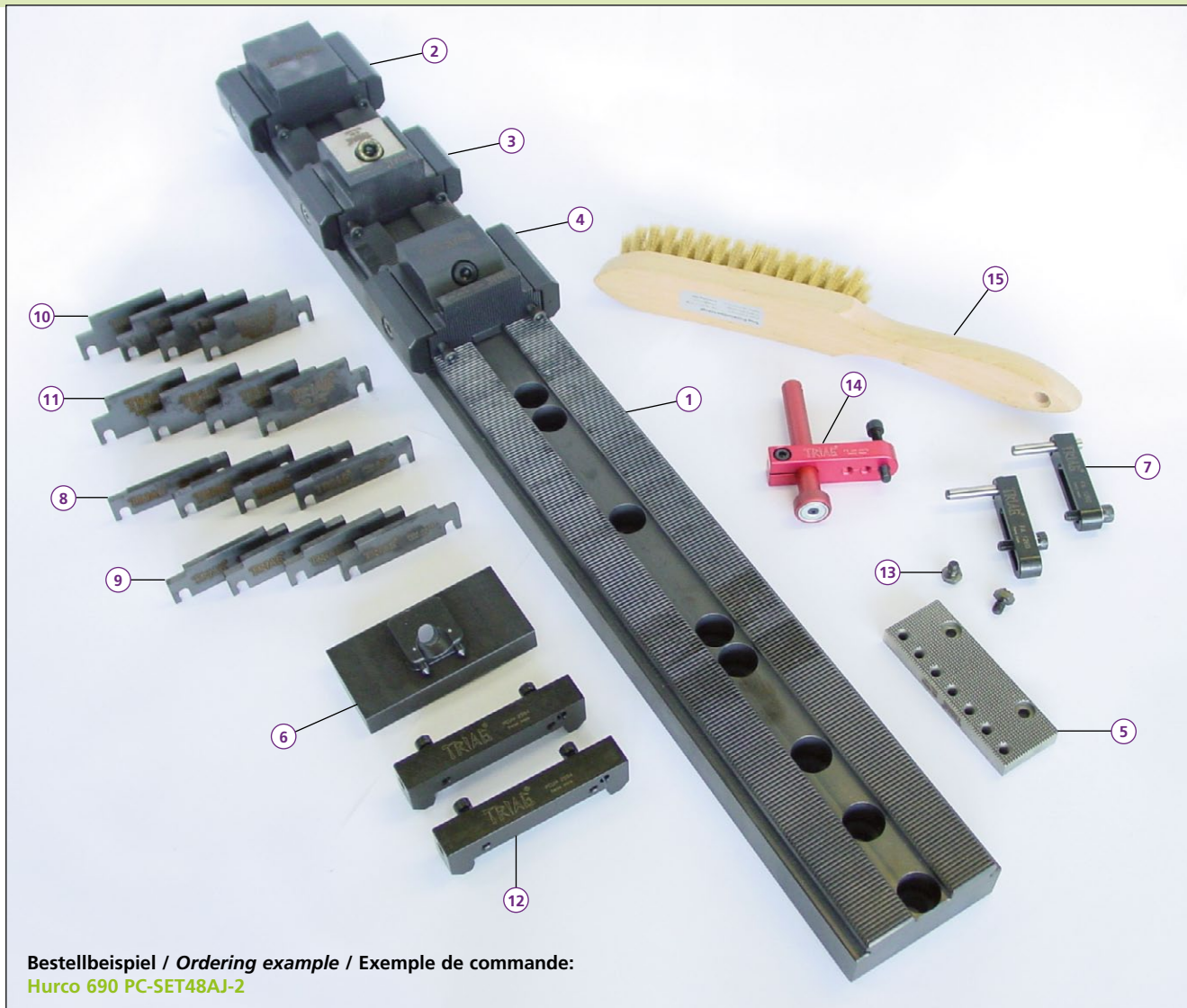

Bestellbeispiel / Ordering example / Exemple de commande:
Hurco 690 PC-SET48AJ-2

Ihr Vorteil mit dem Hurco-Starterset:

Mit dem Hurco-Starterset haben Sie mit Ihren Werkzeugen in der Z-Achse immer Zugang zu Ihren Werkstücken. Die Basisschiene PCB100690H60 wurde für die Hurco speziell in der Höhe 60 mm angefertigt um den eher grossen Abstand von der Spindelnase zum Tisch auf der untersten Position der Z-Achse zu überbrücken bzw. auszugleichen.

The advantage of the Hurco starter-set:

Always reach your work-piece in z-axis with your tools. The base rail PCB100690H60 of the Hurco starter-set is specially developed in the height of 60 mm to bridge the gap between the spindle-nose and your machine table if the spindle is positioned at lowest z-axis position.

Votre avantage avec le set d'introduction Hurco:

Avec le set d'introduction Hurco, dans l'axe Z vous avez toujours accès à vos pièces, avec vos outils. Le rail de base PCB 100 690 H60 Hurco a été spécialement développé avec une hauteur de 60 mm. Pour compenser la distance assez grande du nez de la broche à la table à la position la plus basse de l'axe Z.

Spannmodule
Clamping module
Module de serrage

PS1R/F 19N49 -20
PS5X 19N49 -20

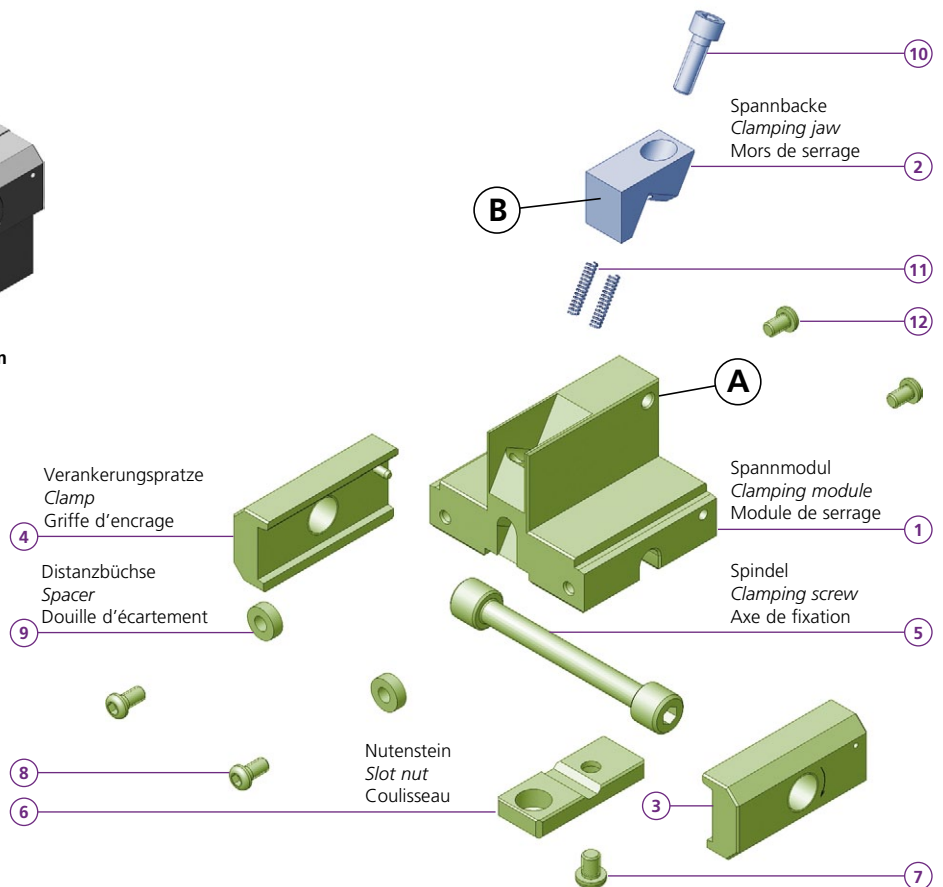
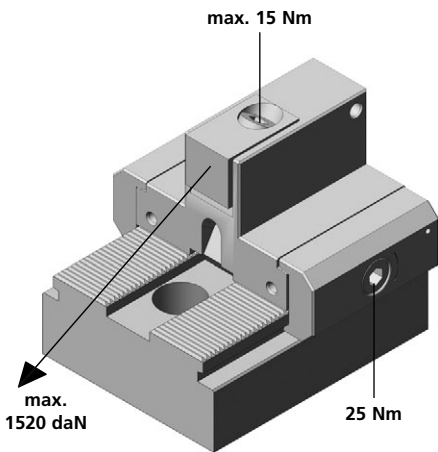
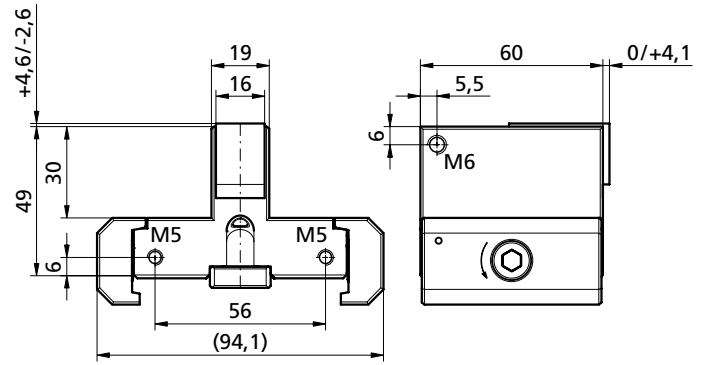
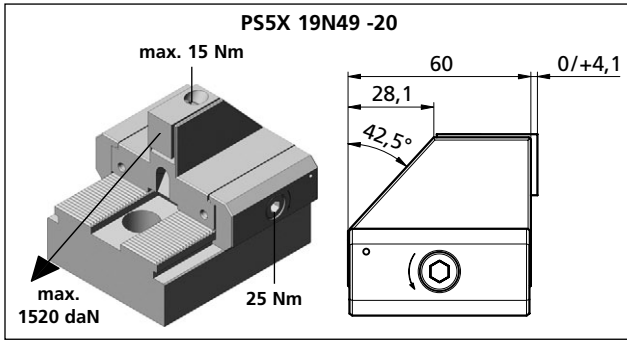

PS5X 19N49 -20
① 1x TF140449
PS1F 19N49 -20
① 1x TF150961
PS1R 19N49 -20
① 1x TF140448
② 1x
③ 1x PCSP 60R
④ 1x PCSP 60L
⑤ 1x PCS 14
⑥ 1x PCGU 20 49
⑦ 1x M6x8 ISO 7380
⑧ 2x M5x14 ISO 4762
⑨ 2x PCD 005
⑩ 1x M6x20 ISO 4762
⑪ 2x FED 0418
⑫ 2x M5x10 ISO 4762
kg ~1,2

Bestellbeispiel / Ordering example / Exemple de commande:
 1x PS1R 19N49 -20 & 1x B21

	B20	B21	B22
③	16	16	16
④	20	20	20
⑤	19	19	19
⑥	6,5	6,5	6,5
⑦	12	12	12
⑧	HV700 x0,2mm	HV700 x0,2mm	*

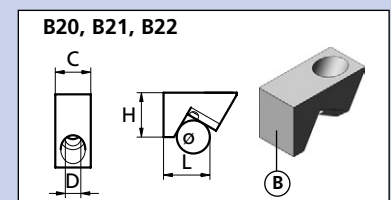

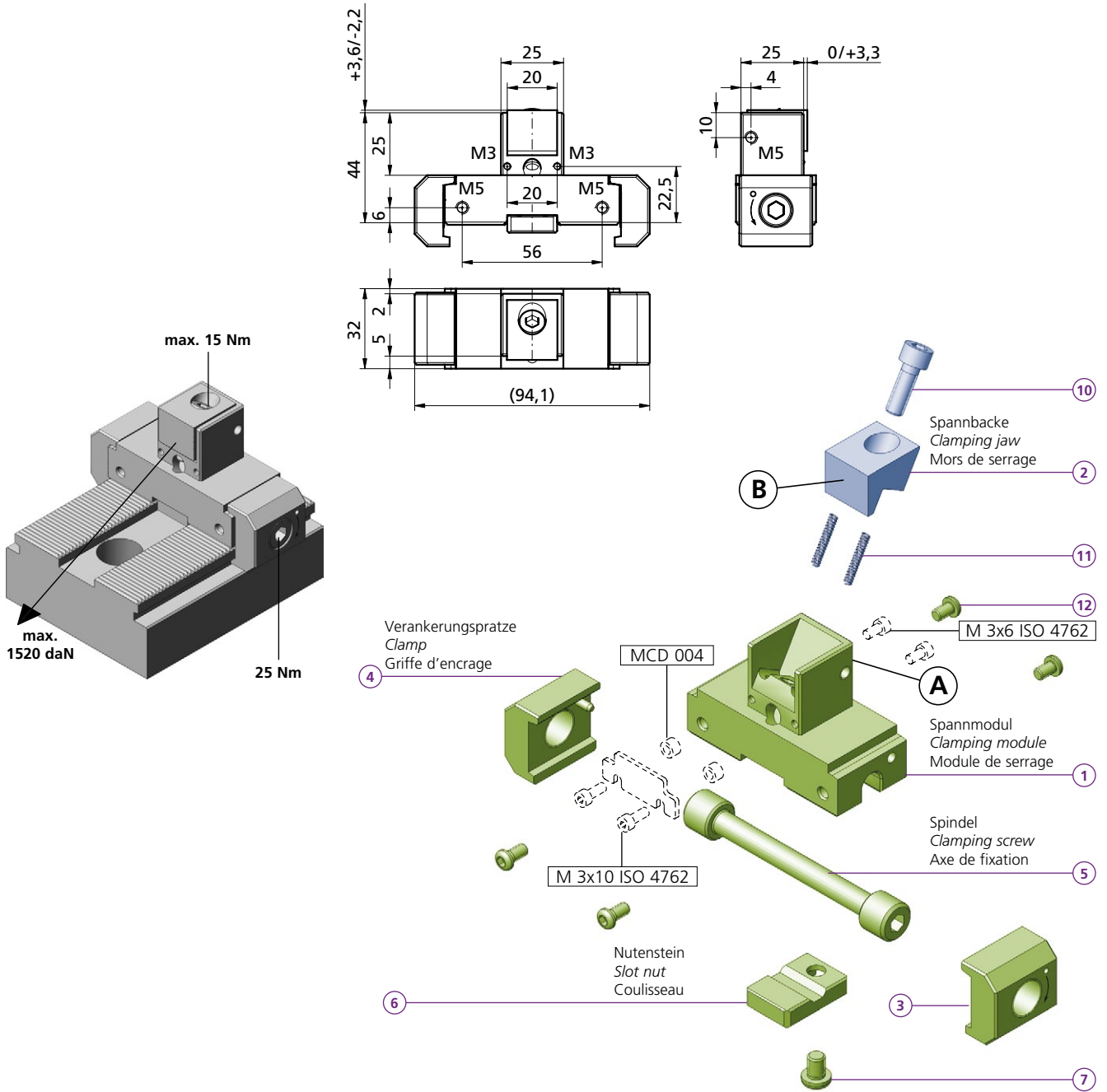

Bestellbeispiel / Ordering example / Exemple de commande:
1x PS1R 25N44 -13 & 1x B14

PS1F 25N44 -13	
1	1x TF150960
PS1R 25N44 -13	
1	1x TF140450
2	1x
3	1x PCSP 30R
4	1x PCSP 30L
5	1x PCS 14
6	1x PCGU 20 30
7	1x M6x8 ISO 7380
10	1x M6x16 ISO 4762
11	2x FED 03018
12	4x M5x10 ISO 4762
kg	~0,65

	B13	B14	B15	B16
C	20	20	20	20
H	16	16	16	16
L	13,8	13,8	13,8	13,8
D	6,5	6,5	6,5	6,5
ø	10	10	10	10
i	HV700 x0,2mm	HV700 x0,2mm	*	*

MCU		H	B	N
11037		11	23	2
15037		15	23	2
18037		18	23	2
20037		20	23	2
22537		22,5	23	2
2x	M3x10 ISO 4762			
2x	M3x6 ISO 4762			
2x	MCD 004			

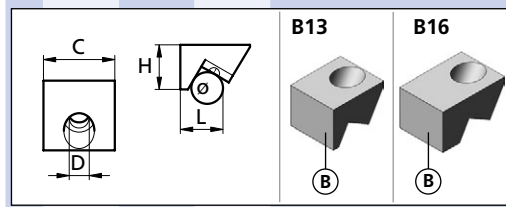

* = weich / soft / doux



PS1R/F 26N49 -26 PS5X 26N49 -26

powerCLAMP

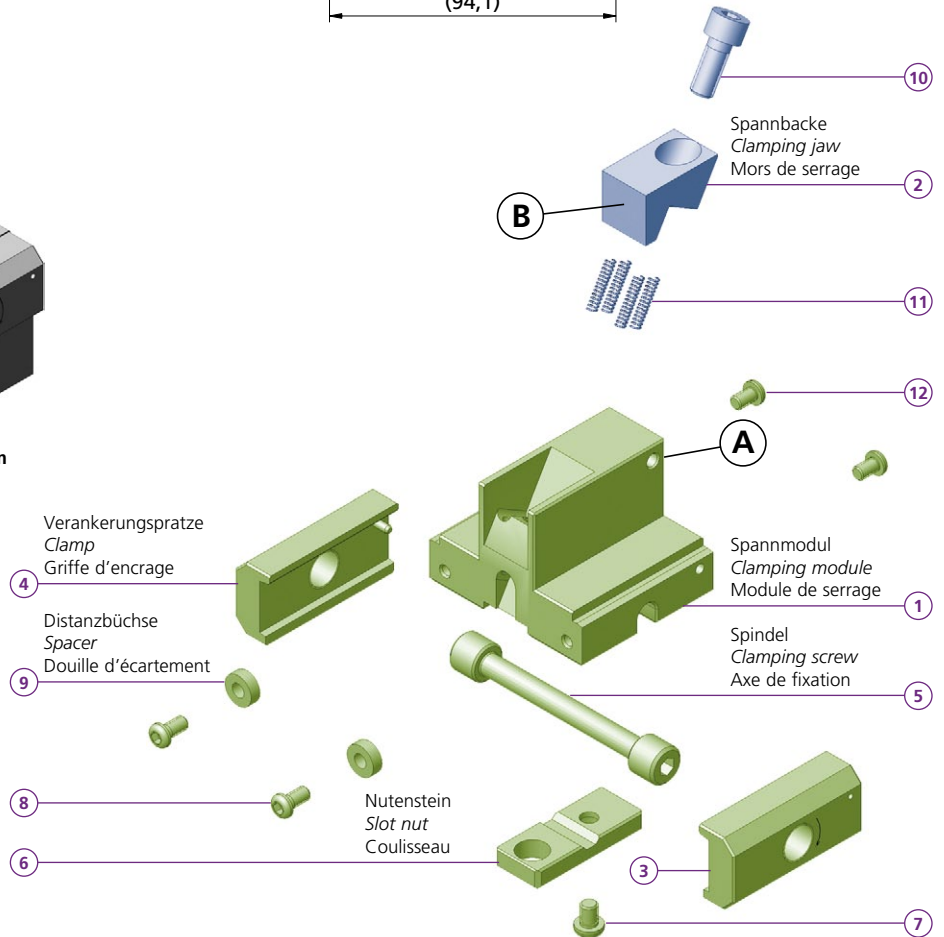
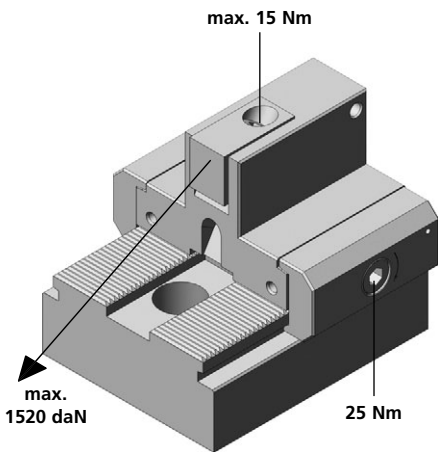
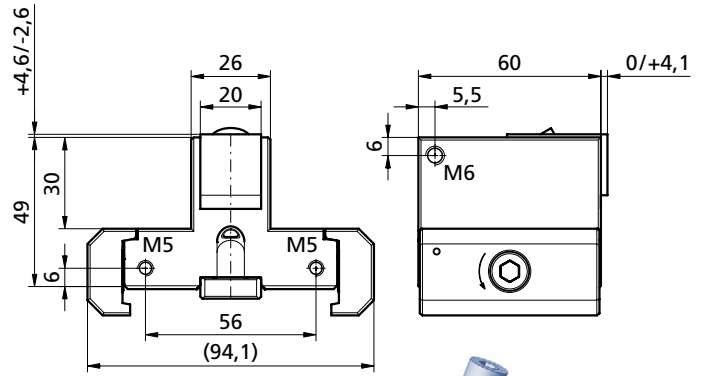
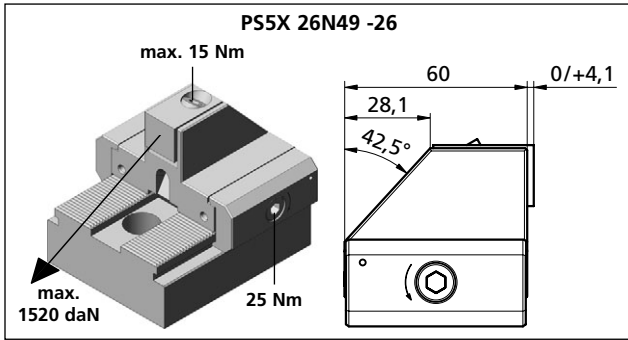

PS5X 26N49 -26
1x TF140453
PS1F 26N49 -26
1x TF140451
PS1R 26N49 -26
1x TF140452
1x
1x PCSP 60R
1x PCSP 60L
1x PCS 14
1x PCGU 20 49
1x M6x8 ISO 7380
2x M5x14 ISO 4762
2x PCD 005
1x M6x20 ISO 4762
4x FED 0418
2x M5x10 ISO 4762
kg ~1,2

Bestellbeispiel / Ordering example / Exemple de commande:
1x PS1R 26N49 -26 & 1x B26

	B26	B27	B28
C	20	20	20
H	20	20	20
L	19	19	19
D	9	9	9
o	12	12	12
i	56HRC	56HRC	*

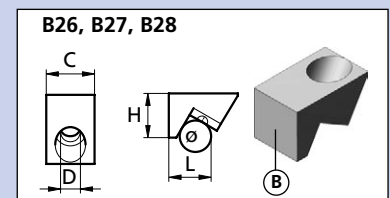

Separat bestellen / Separate order / Commander séparément



PS1R 34N49 -45

PS5X 34N49 -45

powerCLAMP

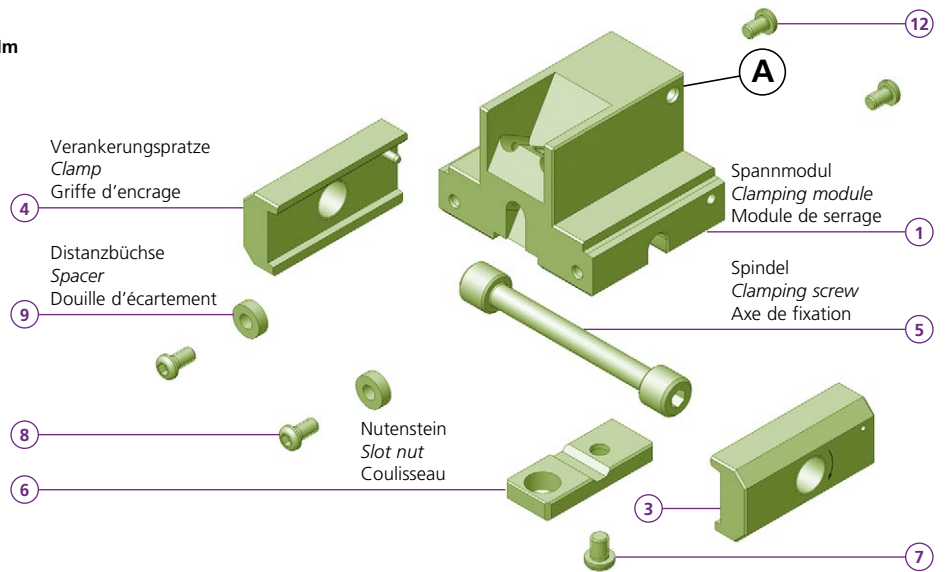
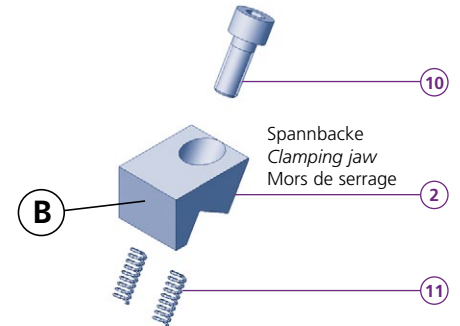
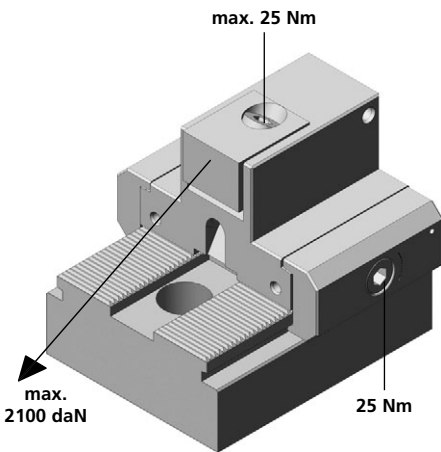
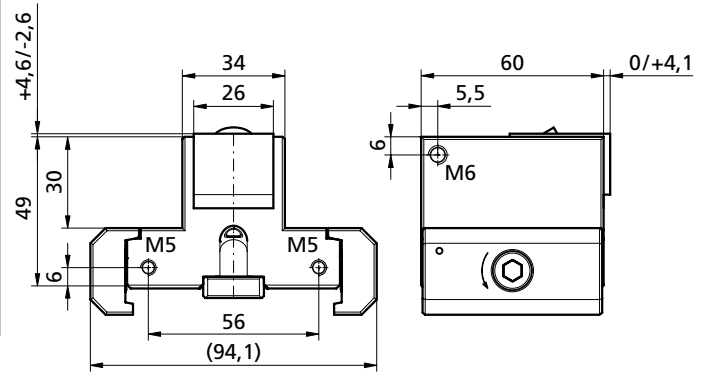
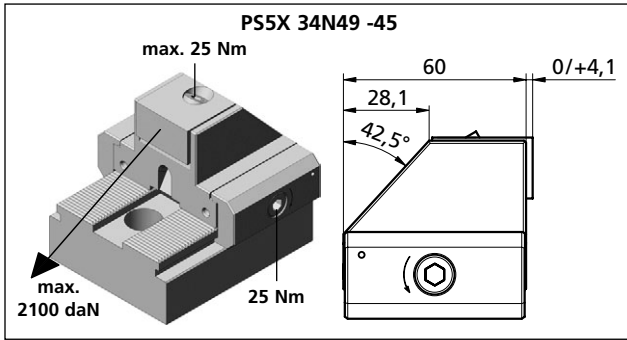

Bestellbeispiel / Ordering example / Exemple de commande:
1x PS5X 34N49 -45 & 1x B47HM

PS5X 34N49 -45	
1	1x TF140455
PS1R 34N49 -45	
1	1x TF140454
2	1x
3	1x PCSP 60R
4	1x PCSP 60L
5	1x PCS 14
6	1x PCGU 20 49
7	1x M6x8 ISO 7380
8	2x M5x14 ISO 4762
9	2x PCD 005
10	1x M6x20 ISO 4762
11	2x FED 0418
12	2x M5x10 ISO 4762
kg	~1,4

	B45	B46	B47	B47HM
C	26	26	26	26
H	20	20	20	20
L	19	19	19,1	19,1
D	9	9	9	9
e	12	12	12	12
i	HV700 x0,2mm	HV700 x0,2mm	*	HM

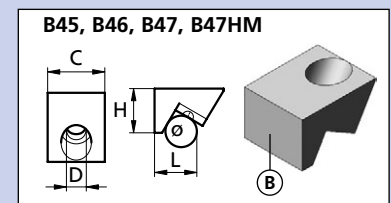

* = weich / soft / doux

HM = Hartmetallbeschichtet / Carbide coated / Revêtuë avec carbure



PS1R/F 43N49 -60

PS1R/F 43N62 -60

PS5X 43N49 -60

powerCLAMP

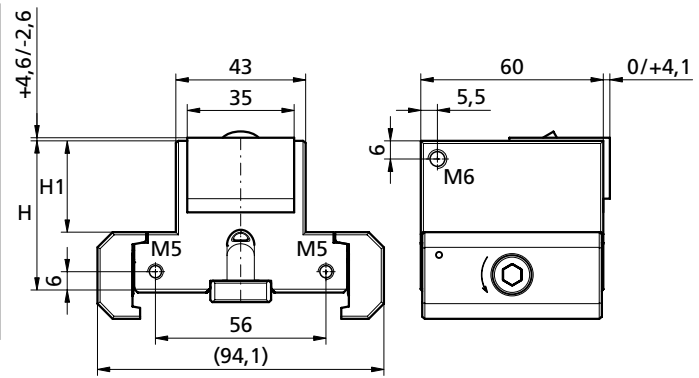
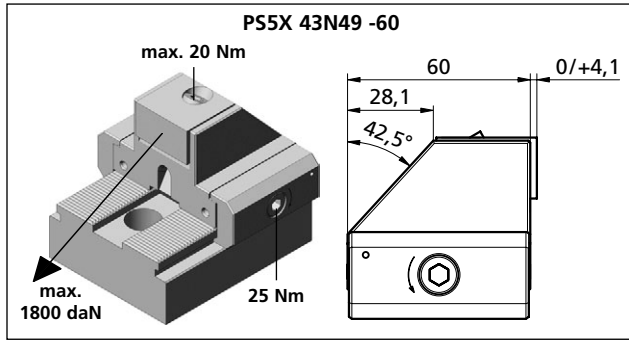

- PS5X 43N49 -60**
- 1x TF140458
- PS1F 43N49 -60**
- 1x TF140456
- PS1R 43N49 -60**
- 1x TF140457
 - 1x
 - 1x PCSP 60R
 - 1x PCSP 60L
 - 1x PCS 14
 - 1x PCGU 20 49
 - 1x M6x8 ISO 7380
 - 2x M5x14 ISO 4762
 - 2x PCD 005
 - 1x M8x20 ISO 4762
 - 2x FED 0618
 - 2x M5x10 ISO 4762
- H1 = 49
H2 = 30
kg ~1,4

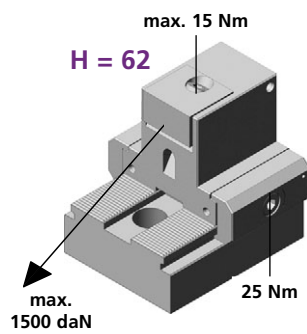
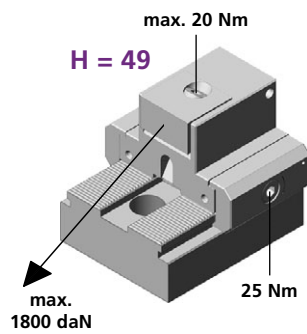

- PS1F 43N62 -60**
- 1x TF140459
- PS1R 43N62 -60**
- 1x TF140460
- H1 = 62
H2 = 43
kg ~1,7

Verankerungspratze
Clamp
Griffe d'encrage

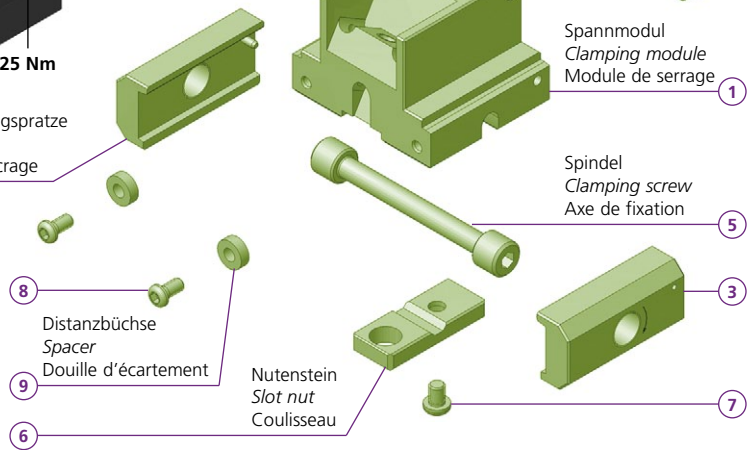

Spannbacke
Clamping jaw
Mors de serrage

Spannmodul
Clamping module
Module de serrage

Spindel
Clamping screw
Axe de fixation

Distanzbüchse
Spacer
Douille d'écartement

Nutenstein
Slot nut
Coulisseau

Bestellbeispiel / Ordering example / Exemple de commande:

1x PS1R 43N49 -60 & 1x B61

	B58	B60	B61	B62	B62HM	B65	B66	B67	B68	B69	B77	B79	B79R
C	35	35	35	35	35	35	35	35	35	35	35	35	35
H	20	20	20	20	20	20	20	20	20	20	20	20	20
L	24	19	19	19	19	19	19	24	26	22	22	25	25
D	9	9	9	9	9	9	9	9	9	9	9	9	9
o	12	12	12	12	12	12	12	12	12	12	12	12	12
i	ALU *	56 HRC	56 HRC	*	HM	HV700 x0,2mm	HV700 x0,2mm	HV700 x0,2mm	*	*	56 HRC	HV700 x0,2mm	HV700 x0,2mm

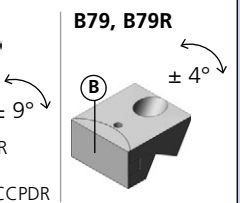
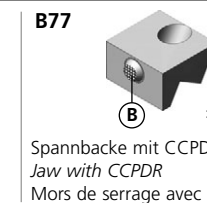
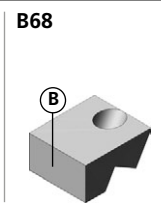
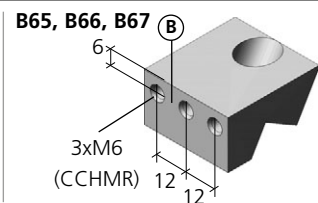
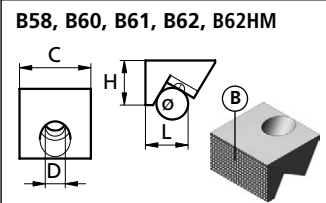
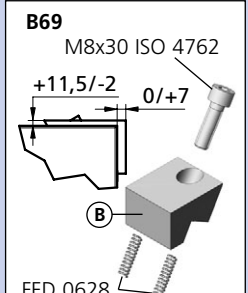

PS1R/F 48N34 -80

PS1R/F 58N34 -80

PS1R/F 68N34 -80



powerCLAMP

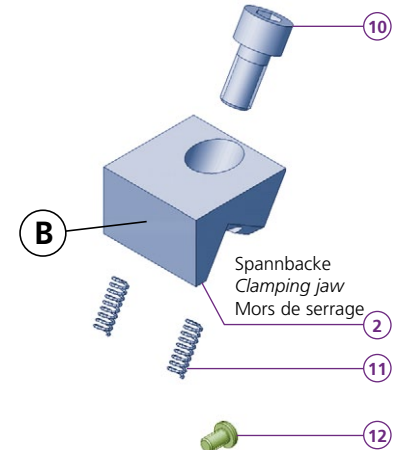
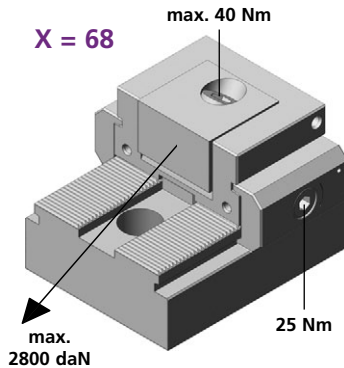
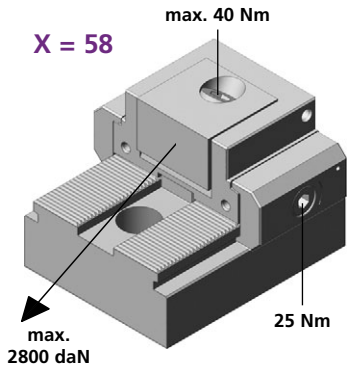
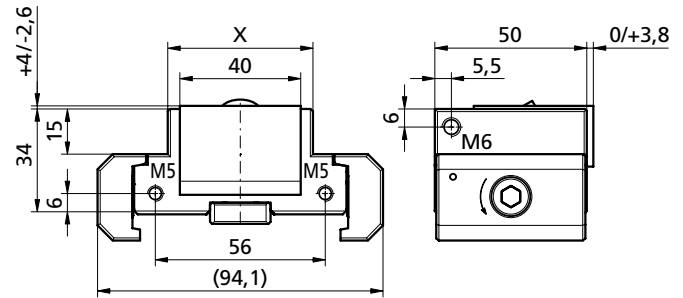
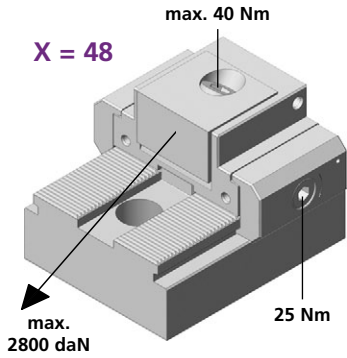

- PS1F 48N34 -80**
- 1 1x TF140461
- PS1R 48N34 -80**
- 1 1x TF140462
 - 2 1x
 - 3 1x PCSP 50R
 - 4 1x PCSP 50L
 - 5 1x PCS 14
 - 6 1x PCGU 20 49
 - 7 1x M6x8 ISO 7380
 - 8 2x M5x14 ISO 4762
 - 9 2x PCD 005
 - 10 1x M10x25 ISO 4762
 - 11 2x FED 0618
 - 12 2x M5x10 ISO 4762
- X = 48
kg ~1,0

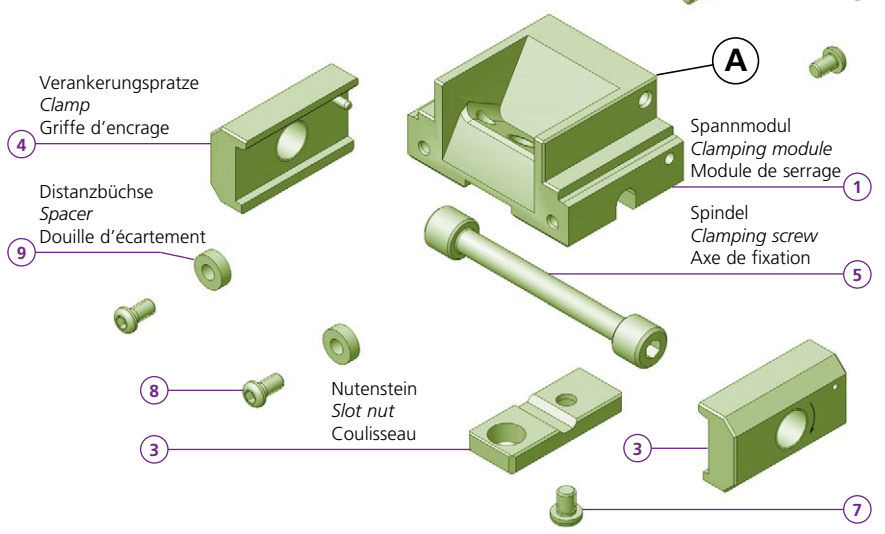

- PS1F 58N34 -80**
- 1 1x TF140463
- PS1R 58N34 -80**
- 1 1x TF140464
- X = 58
kg ~1,0

- PS1F 68N34 -80**
- 1 1x TF140465
- PS1R 68N34 -80**
- 1 1x TF140466
- X = 68
kg ~1,1

Bestellbeispiel / Ordering example / Exemple de commande:
1x PS1F 68N34 -80 & 1x B82HM

	B80	B81	B82	B82L33	B82HM	B83	B89
C	40	40	40	40	40	40	40
H	25	25	25	25	25	25	25
L	22	22	22,2	33	22,2	22	29
D	11	11	11	11	11	11	11
ø	15	15	15	15	15	15	15
i	56HRc	56HRc	*	*	56HRc	HV700 x0,2mm	HV700 x0,2mm

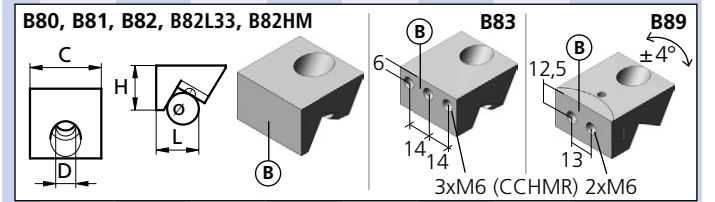

* = weich / soft / doux

HM = Hartmetallbeschichtet / Carbide coated / Revêtu avec carbure

Separat bestellen / Separate order / Commander séparément



PS1R/F 48N49 -80

PS1R 48N75 -80

PS5X 48N49 -80

powerCLAMP

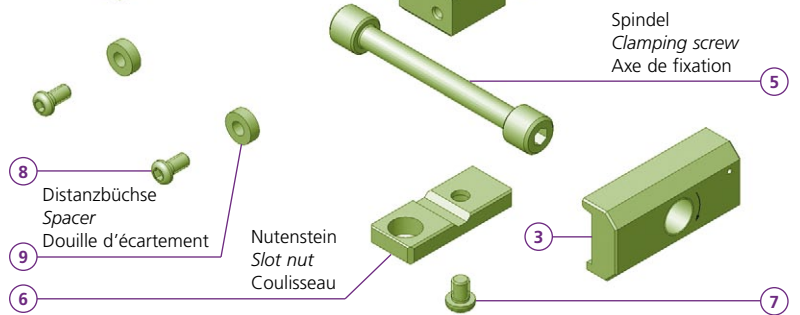
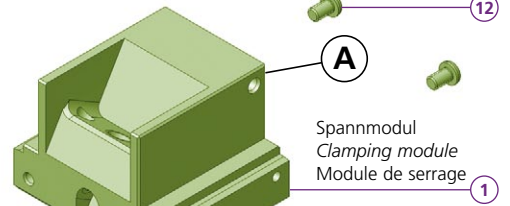
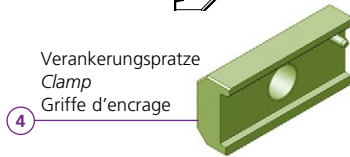
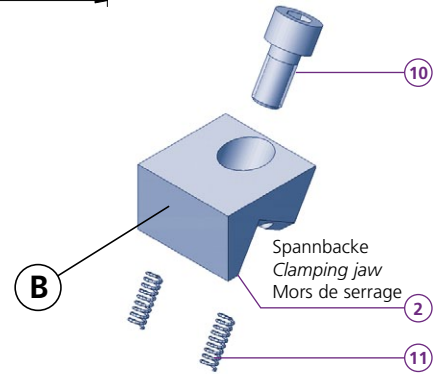
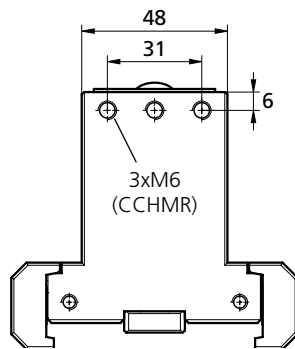
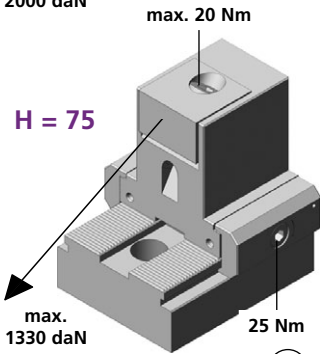
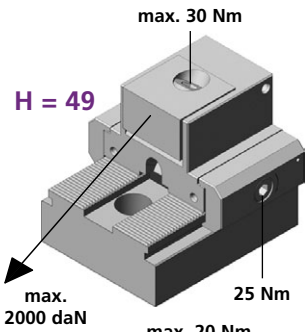
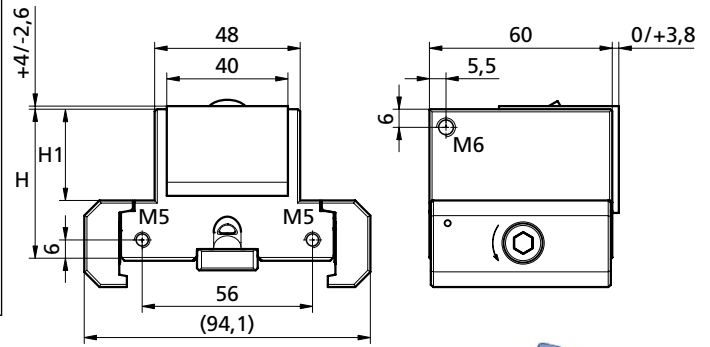
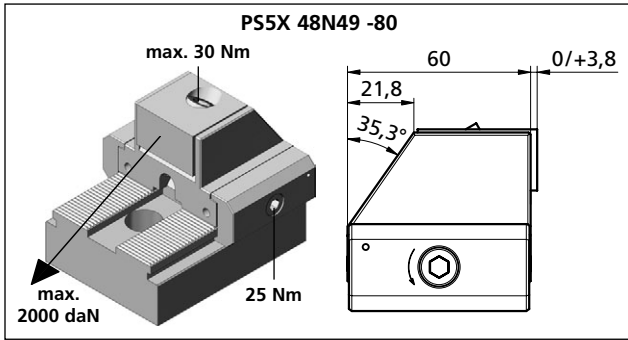

- PS5X 48N49 -80**
- 1x TF140469
- PS1F 48N49 -80**
- 1x TF140467
- PS1R 48N49 -80**
- 1x TF140468

- 1x
 - 1x PCSP 60R
 - 1x PCSP 60L
 - 1x PCS 14
 - 1x PCGU 20 49
 - 1x M6x8 ISO 7380
 - 2x M5x14 ISO 4762
 - 2x PCD 005
 - 1x M10x25 ISO 4762
 - 2x FED 0618
 - 2x M5x10 ISO 4762
- H1 = 49
- H2 = 30
- kg ~1,5

- PS1R 48N75 -80**
- 1x TF140471
- H1 = 75
- H2 = 56
- kg ~2,2

Bestellbeispiel / Ordering example / Exemple de commande:
1x PS1F 48N49 -80 & 1x B80

	B80	B81	B82	B82L33	B82HM	B83	B89
C	40	40	40	40	40	40	40
H	25	25	25	25	25	25	25
L	22	22	22,2	33	22,2	22	29
D	11	11	11	11	11	11	11
ø	15	15	15	15	15	15	15
i	56HRc	56HRc	*	*	56HRc	HV700	HV700
						x0,2mm	x0,2mm

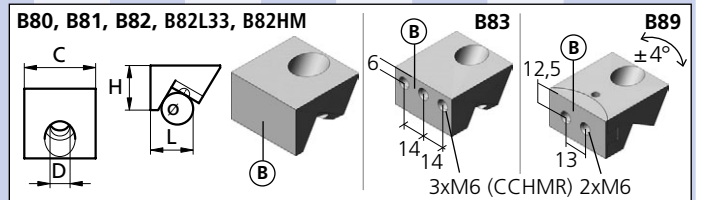

PS1R/F 78N34 -80

PS1R/F 78N49 -80

PS1R/F 94N34 -80



powerCLAMP

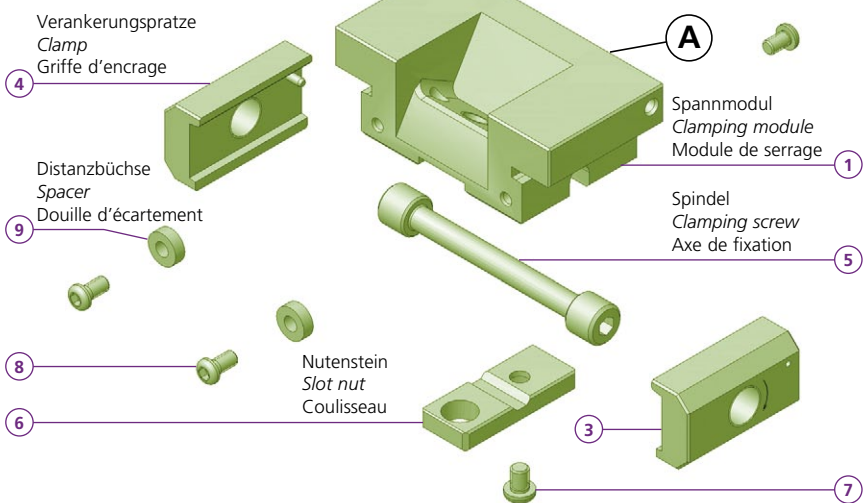
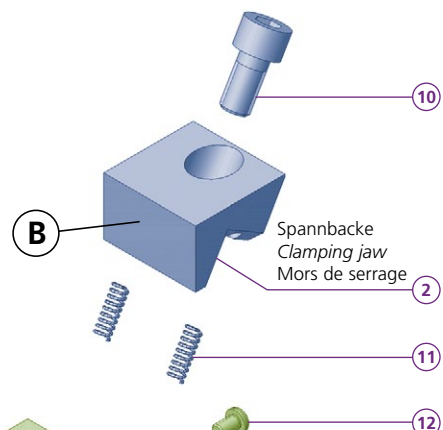
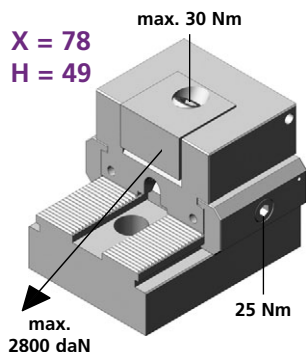
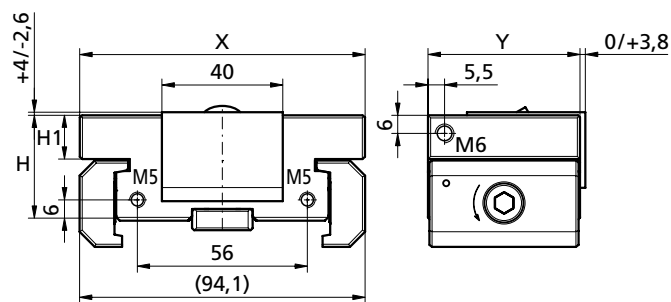
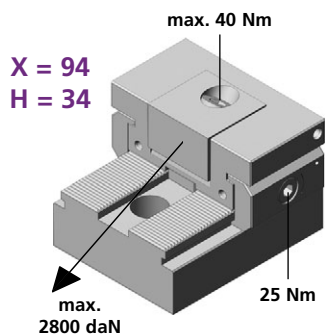
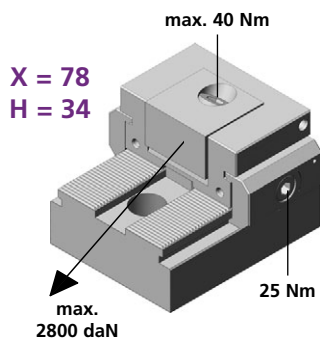

- PS1F 78N34 -80**
- 1 1x TF140472
- PS1R 78N34 -80**
- 1 1x TF140473
 - 2 1x _____
 - 3 1x PCSP 50R
 - 4 1x PCSP 50L
 - 5 1x PCS 14
 - 6 1x PCGU 20 49
 - 7 1x M6x8 ISO 7380
 - 8 2x M5x14 ISO 4762
 - 9 2x PCD 005
 - 10 1x M10x25 ISO 4762
 - 11 2x FED 0618
 - 12 2x M5x10 ISO 4762
- X = 48
H = 34
H2 = 15
Y = 50
kg ~1,0

- PS1F 94N34 -80**
- 1 1x TF140476
- PS1R 94N34 -80**
- 1 1x TF140477
- X = 94
H = 34
H2 = 15
Y = 50
kg ~1,4

- PS1F 78N49 -80**
- 1 1x TF140474
- PS1R 78N49 -80**
- 1 1x TF140475
 - 3 1x PCSP 60R
 - 4 1x PCSP 60L
- X = 78
H = 49
H2 = 30
Y = 60
kg ~1,4

Bestellbeispiel / Ordering example / Exemple de commande:
1x PS1R 94N34 -80 & 1x B80

	B80	B81	B82	B82L33	B82HM	B83	B89
C	40	40	40	40	40	40	40
H	25	25	25	25	25	25	25
L	22	22	22,2	33	22,2	22	29
D	11	11	11	11	11	11	11
ø	15	15	15	15	15	15	15
i	56HRc	56HRc	*	*	56HRc	HV700 x0,2mm	HV700 x0,2mm

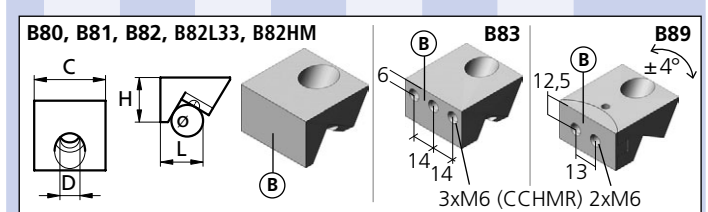

* = weich / soft / doux

HM = Hartmetallbeschichtet / Carbide coated / Revêtuë avec carbure

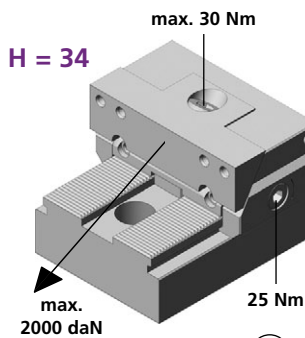
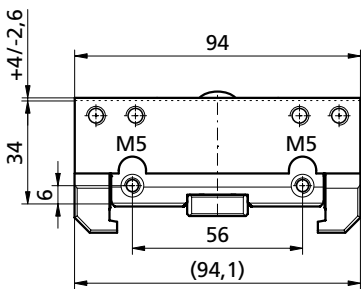
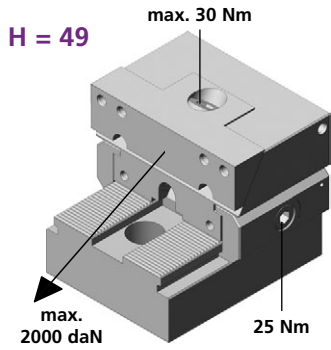
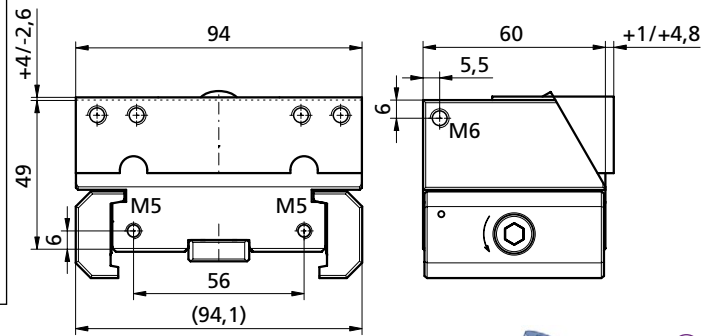
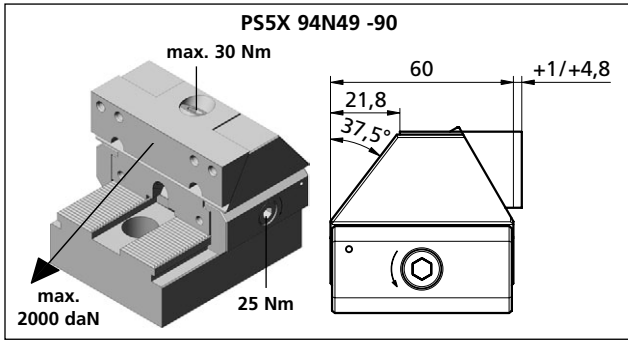

PS1F 94N34 -90	
1	1x TF140478
PS1R 94N34 -90	
1	1x TF140479
2	1x
3	1x PCSP 50R F
4	1x PCSP 50L F
5	1x PCS 14
6	1x PCGU 20 49
7	1x M6x8 ISO 7380
8	2x M5x16 ISO 4762
9	2x PCD 008
10	1x M10x25 ISO 4762
11	2x FED 0618
12	2x M5x10 ISO 4762
H	= 34
kg	~1,4

PS5X 94N49 -90	
1	1x TF140482
PS1F 94N49 -90	
1	1x TF140480
PS1R 94N49 -90	
1	1x TF140481
2	1x
3	1x PCSP 60R
4	1x PCSP 60L
8	2x M5x14 ISO 4762
9	2x PCD 005
H	= 49
kg	~2,0

Verankerungsplatte
Clamp
Griffe d'encrage

8 Distanzbüchse
Spacer
Douille d'écartement

6 Nutenstein
Slot nut
Coulisseau

10 Spannbacke
Clamping jaw
Mors de serrage

11

12

1 Spannmodul
Clamping module
Module de serrage

5 Spindel
Clamping screw
Axe de fixation

3

Bestellbeispiel / Ordering example / Exemple de commande:
1x PS1F 94N34 -90 & 1x B91

	B90	B91	B92	B93	B94
C	94	94	94	94	94
H	25	25	25	25	25
L	23	23	23	23	40
D	11	11	11	11	11
e	15	15	15	15	15
i	HV700 x0,2mm	HV700 x0,2mm	*	HV700 x0,2mm	*

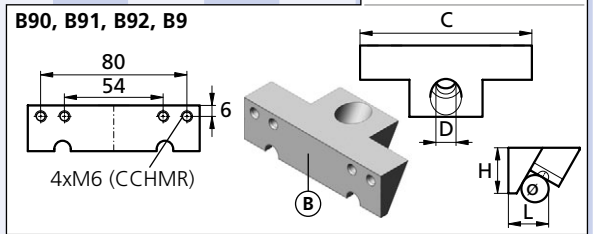

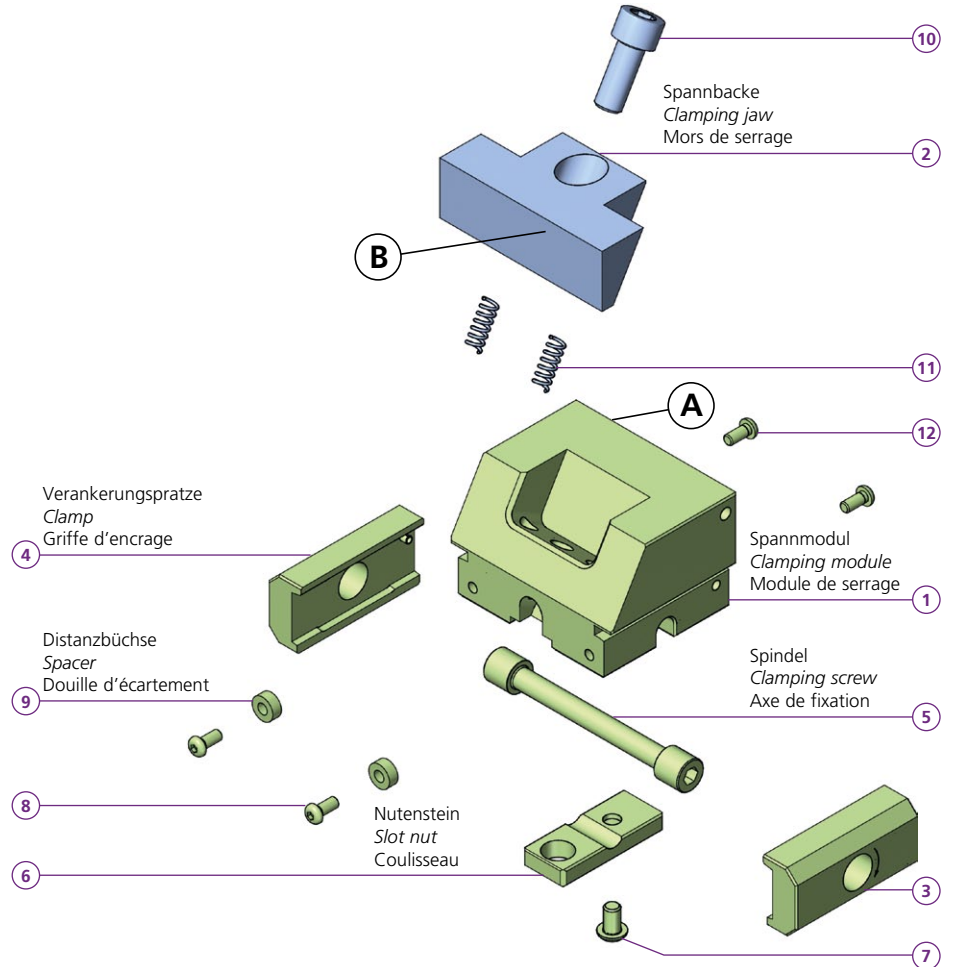
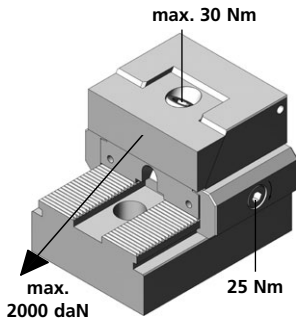
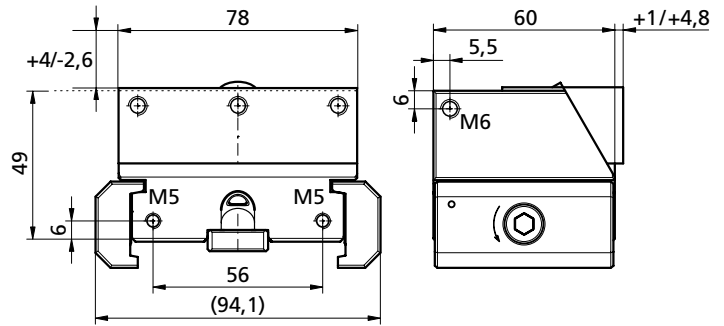

PS1F 78N49 -90	A
1x TH160490	
PS1R 78N49 -90	
1x TH160490	
1x	
1x PCSP 60R	
1x PCSP 60L	
1x PCS 14	
1x PCGU 20 49	
1x M6x8 ISO 7380	
2x M5x16 ISO 4762	
2x PCD 008	
1x M10x25 ISO 4762	
2x FED 0618	
2x M5x10 ISO 4762	
kg ~1,4	

Bestellbeispiel / Ordering example / Exemple de commande:
1x PS1F 78N49 -90 & 1x B90F78

	B90F78	B90W78	B90R78
C	78	78	78
H	25	25	25
L	23	28	23
D	11	11	11
e	15	15	15
i	HV700 x0,2mm	*	HV700 x0,2mm

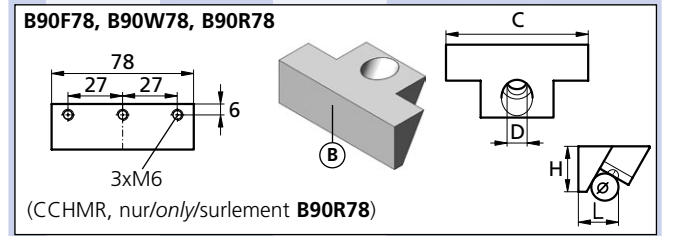

* = weich / soft / doux

Separat bestellen / Separate order / Commander séparément



PS1R/F 125N49 -95

PS5X 125N49 -95

powerCLAMP

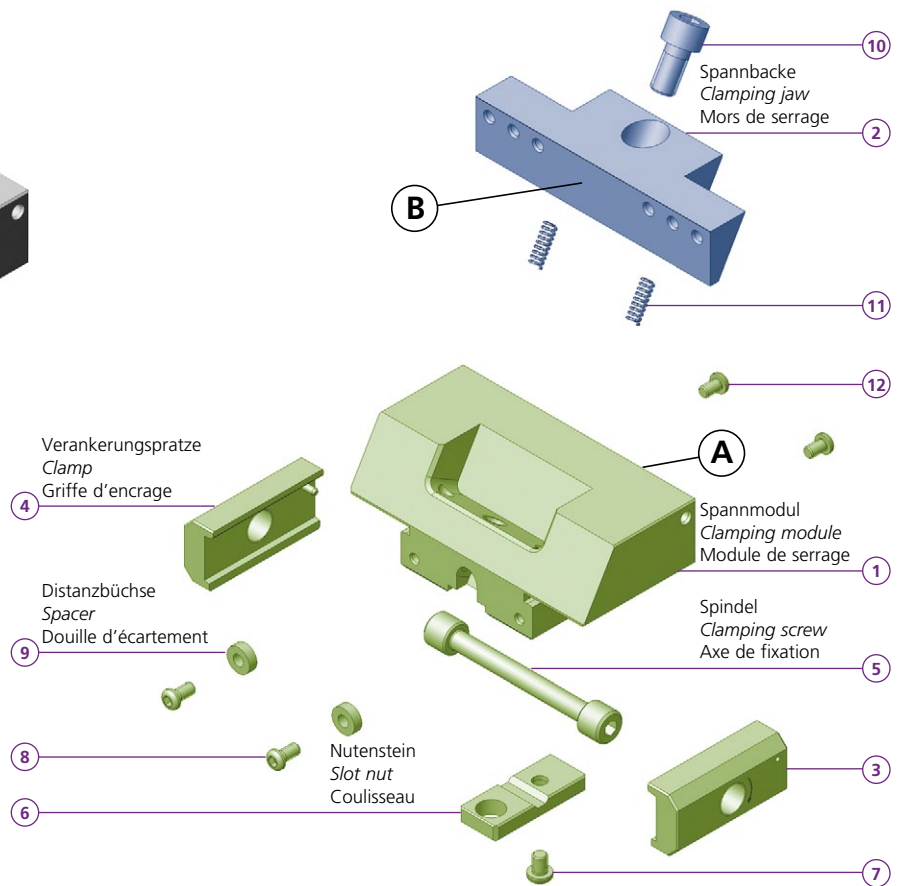
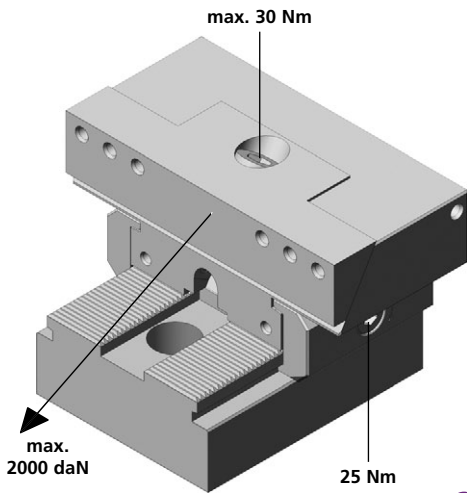
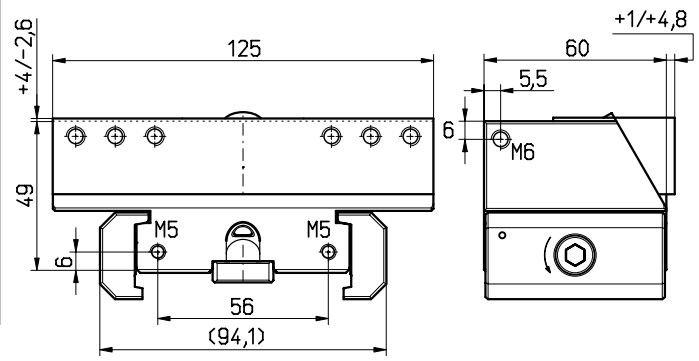
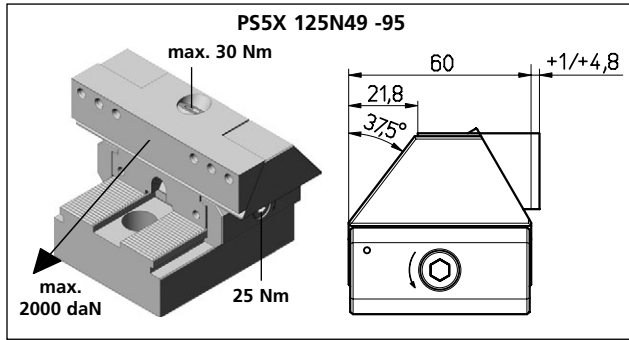

PS5X 125N49 -95	
1	1x TF140485
PS1F 125N49 -95	
1	1x TF140483
PS1R 125N49 -95	
1	1x TF140484
2	1x
3	1x PCSP 60R
4	1x PCSP 60L
5	1x PCS 14
6	1x PCGU 20 49
7	1x M6x8 ISO 7380
8	2x M5x14 ISO 4762
9	2x PCD 005
10	1x M10x25 ISO 4762
11	2x FED 0618
12	2x M5x10 ISO 4762
kg	~2,4

Bestellbeispiel / Ordering example / Exemple de commande:
1x PS5X 125N49 -95 & 1x B95

	B95	B96	B97	B98	B99
C	125	125	125	125	125
H	25	25	25	25	25
L	23	23	23	30	23
D	11	11	11	11	11
o	15	15	15	15	15
i	HV700 x0,2mm	HV700 x0,2mm	*	*	HV700 x0,2mm

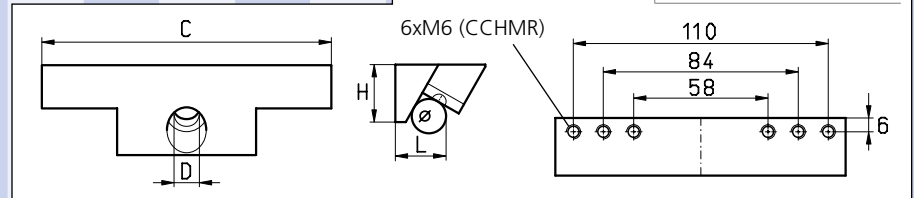
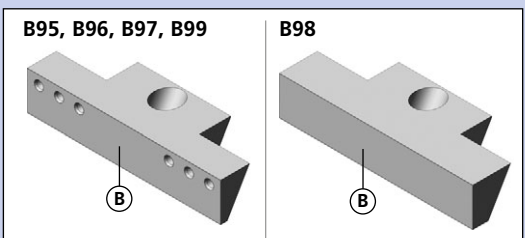



PS2G 94N44 -13

powerCLAMP

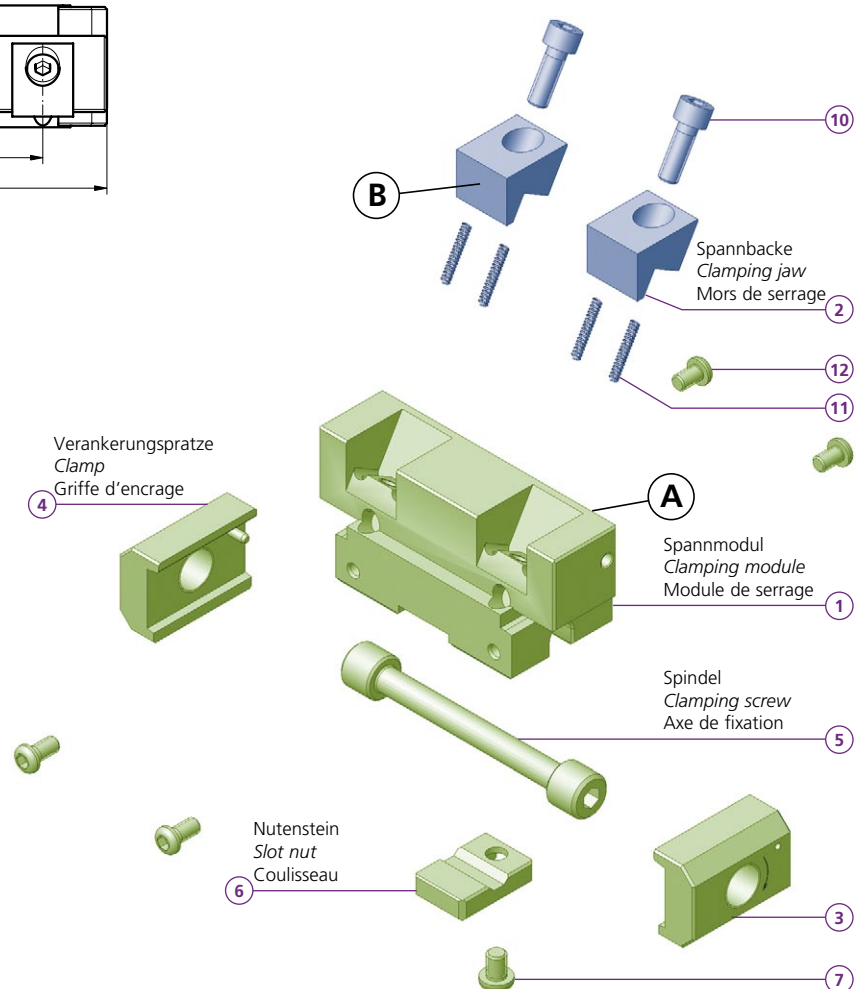
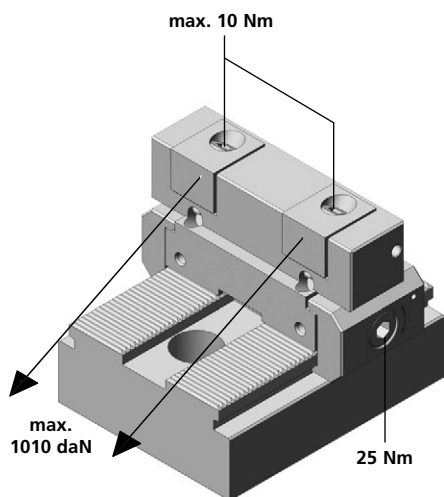
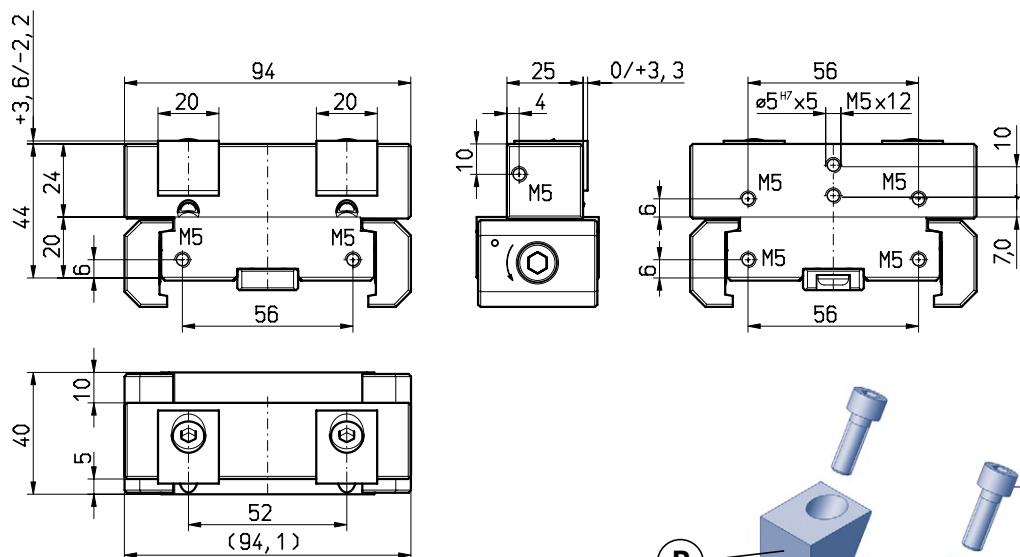

Bestellbeispiel / Ordering example / Exemple de commande:
1x PS2G 94N44 -13 & 2x B14

PS2G 94N44 -13		B13 B14 B15 B16			
1	1x TF140486				
2	2x				
3	1x PCSP 40R				
4	1x PCSP 40L				
5	1x PCS 14				
6	1x PCGU 20 30				
7	1x M6x8 ISO 7380				
10	2x M6x16 ISO 4762				
11	4x FED 0618				
12	4x M5x10 ISO 4762				
kg	~0,6				
		C	H	L	D
		20	20	20	20
		16	16	25	25
		13,8	13,8	13,8	19
		6,5	6,5	6,5	6,5
		10	10	10	10
		HV700 x0,2mm	HV700 x0,2mm	*	*

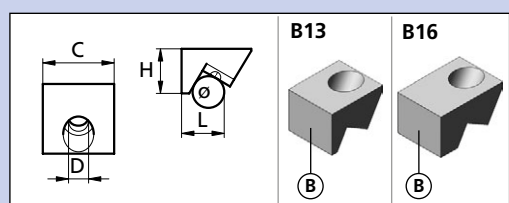

* = weich / soft / doux

Separat bestellen / Separate order / Commander séparément

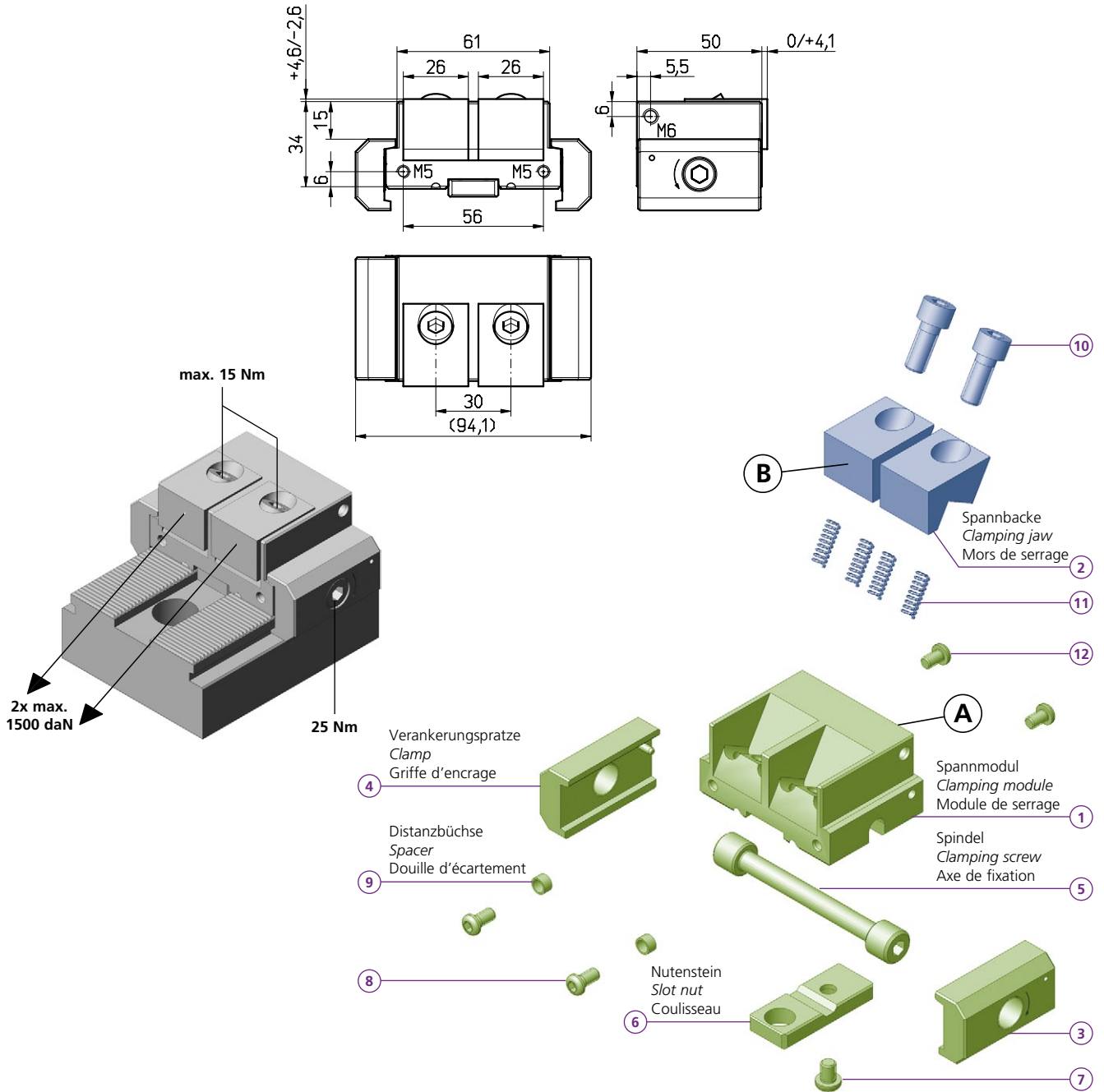

PS2F 61N34 -45	
1	1x TF140487
PS2R 61N34 -45	
1	1x TF140488
2	2x
3	1x PCSP 50R
4	1x PCSP 50L
5	1x PCS 14
6	1x PCGU 20 49
7	1x M6x8 ISO 7380
8	2x M5x16 ISO 4762
9	2x PCD 005
10	2x M8x20 ISO 4762
11	4x FED 0618
12	2x M5x10 ISO 4762
kg	~1,2

	B45	B46	B47	B47HM
C	26	26	26	26
H	20	20	20	20
L	19	19	19,1	19,1
D	9	9	9	9
e	12	12	12	12
i	56HRc	56HRc	*	HM

Bestellbeispiel / Ordering example / Exemple de commande:
1x PS2R 61N34 -45 & 2x B47HM

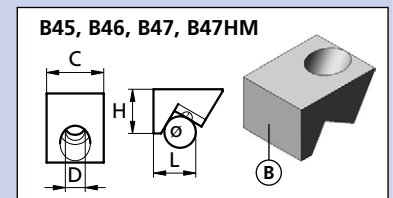



PS2X 94N49 -60

powerCLAMP

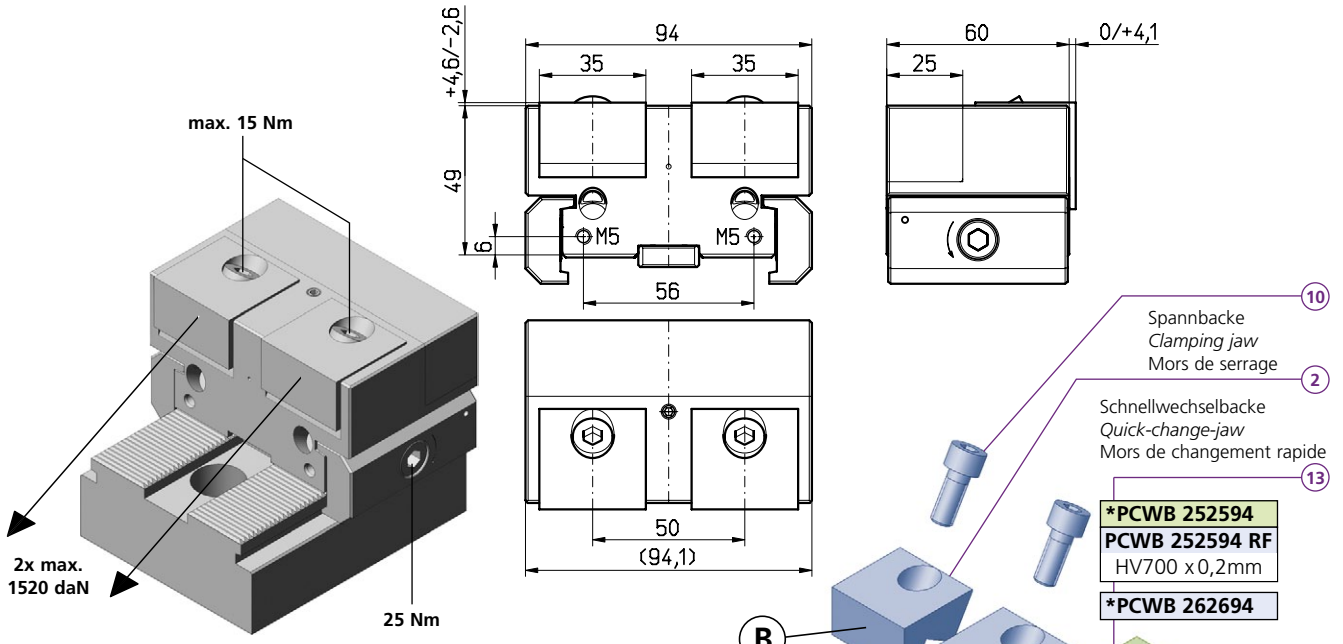

- PS2X 94N49 -60**
- 1 1x TF140489
 - 2 2x
 - 3 1x PCSP 60R
 - 4 1x PCSP 60L
 - 5 1x PCS 14
 - 6 1x PCGU 20 49
 - 7 1x M6x8 ISO 7380
 - 8 2x M5x14 ISO 4762
 - 9 2x PCD 005
 - 10 2x M8x20 ISO 4762
 - 11 4x FED 0618
 - 12 2x M5x10 ISO 4762
 - 13 1x PCWB 2525 94
 - 14 1x PCBO 0605 40
 - 15 1x M5x16 ISO 4026
- kg ~2,2

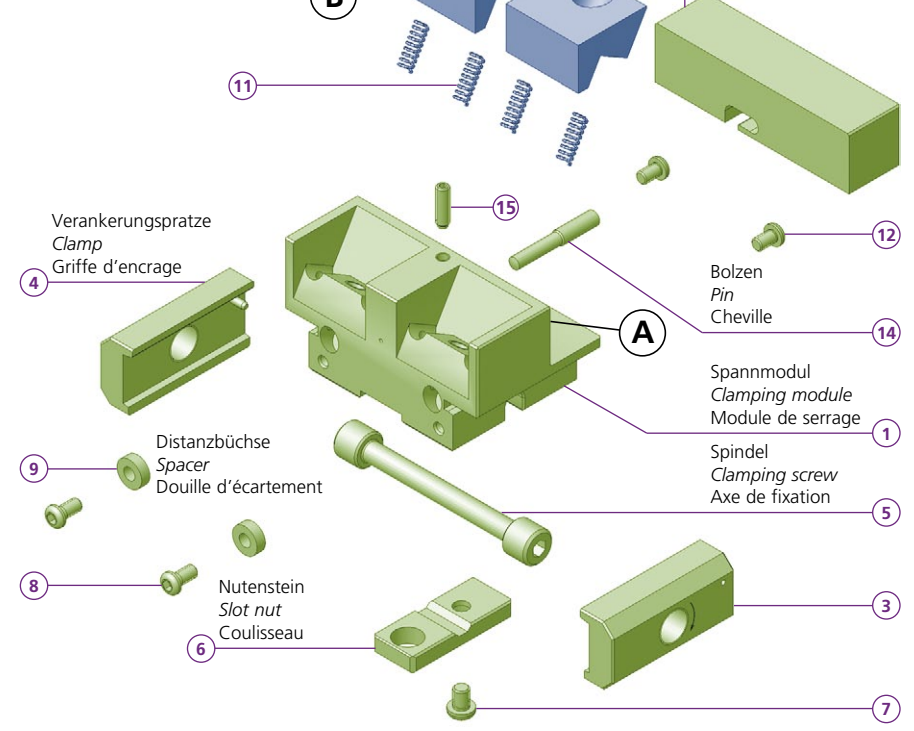

Bestellbeispiel / Ordering example / Exemple de commande:
1x PS2X 94N49 -60 & 2x B58

	B58	B60	B61	B62	B62HM	B65	B66	B67	B68	B69	B77	B79	B79R
C	35	35	35	35	35	35	35	35	35	35	35	35	35
H	20	20	20	20	20	20	20	20	20	20	20	20	20
L	24	19	19	19	19	19	19	24	26	22	22	25	25
D	9	9	9	9	9	9	9	9	9	9	9	9	9
o	12	12	12	12	12	12	12	12	12	12	12	12	12
i	ALU *	56 HRC	56 HRC	*	HM	HV700	HV700	HV700	*	*	56 HRC	HV700	HV700
		x0,2mm	x0,2mm			x0,2mm	x0,2mm	x0,2mm				x0,2mm	x0,2mm

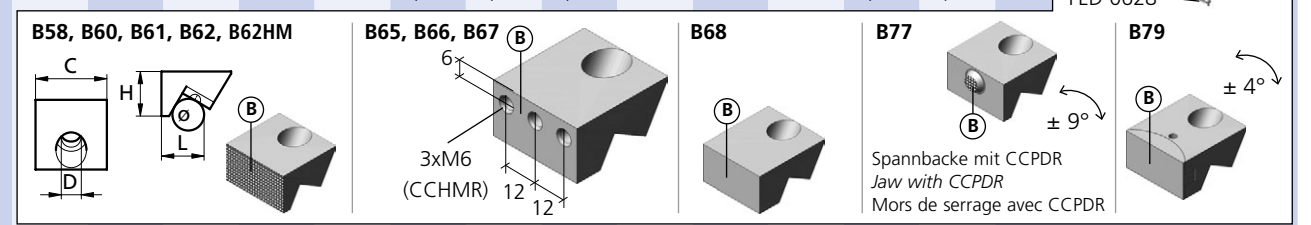
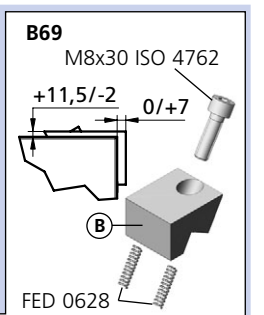

* = weich / soft / doux HM = Hartmetallbeschichtet / Carbide coated / Revêtu avec carbure

Separat bestellen / Separate order / Commander séparément

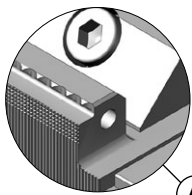
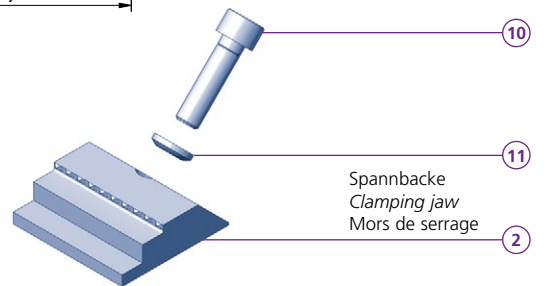
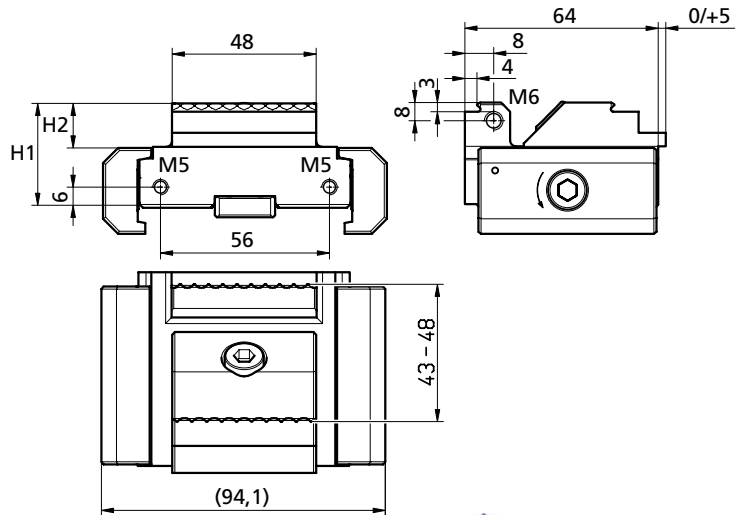
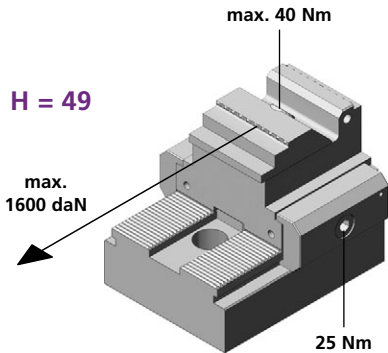
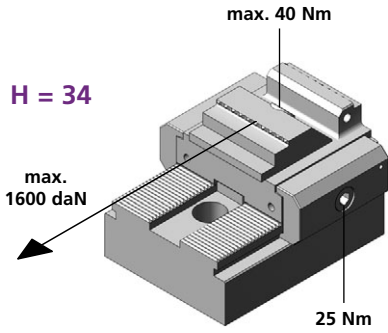

Verankerungspratze
Clamp
Griffe d'encrage

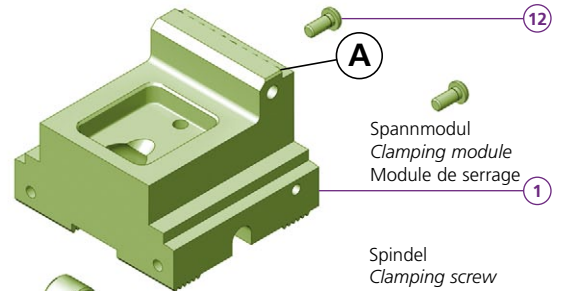
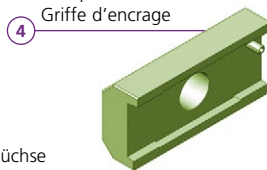

Distanzbüchse
Spacer
Douille d'écartement



Spindel
Clamping screw
Axe de fixation

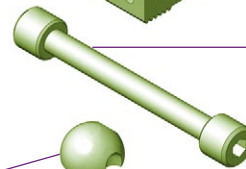

Spindellager
Spindle bearing
Palier de la broche

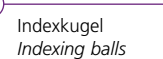

Distanzbüchse
Spacer
Douille d'écartement

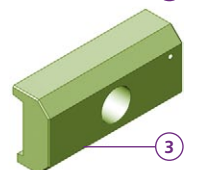

Indexkugel
Indexing balls
Bille d'indexage

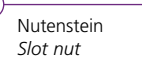

Nutenstein
Slot nut
Coulisseau



PS1P 48L34 -105

- 1 1x TW100098-01
- 2 1x
- 3 1x PCSP 60R
- 4 1x PCSP 60L
- 5 1x PCS 14
- 6 1x PCGU 20 59
- 7 1x M6x8 ISO 7380
- 8 2x M5x14 ISO 4762
- 9 2x PCD 005
- 10 1x M8x30 ISO 4762
- 11 1x PCUSR 14
- 12 2x M5x10 ISO 4762
- 13 1x PCKMR 45 M8
- 14 2x D=6 DIN 5401
- H1 = 34
- H2 = 15
- kg ~1,25

p. 96

Bestellbeispiel / Ordering example / Exemple de commande:
1x PS1P 48L34 -105 & 1x B115

PS1PF 48L34 -105

- 1 1x TK140780
- H1 = 49
- H2 = 30
- kg ~1,25

PS1P 48L49 -105

- 1 1x TK120011
- 15 1x PCD 20L15
- H1 = 49
- H2 = 30
- kg ~1,75

PS1PF 48L49 -105

- 1 1x TK140781
- 15 1x PCD 20L15
- H1 = 49
- H2 = 30
- kg ~1,75

Drehmoment Torque Couple de torsion	Spannkraft Workholding force Force de serrage
10 Nm lb-ft 7,4	= 0,4 t 400 daN
20 Nm lb-ft 14,8	= 0,8 t 800 daN
30 Nm lb-ft 22,2	= 1,2 t 1200 daN
40 Nm lb-ft 29,6	= 1,6 t 1600 daN

PS1P 94L34 -105

PS1P6 94L34 -105

PS1P 94L49 -105

PS1PF 94L49 -105

PS1PF 94L34 -105

Linear



prägen
stamping
imprimer



powerCLAMP

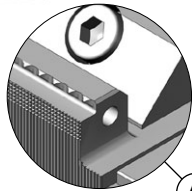
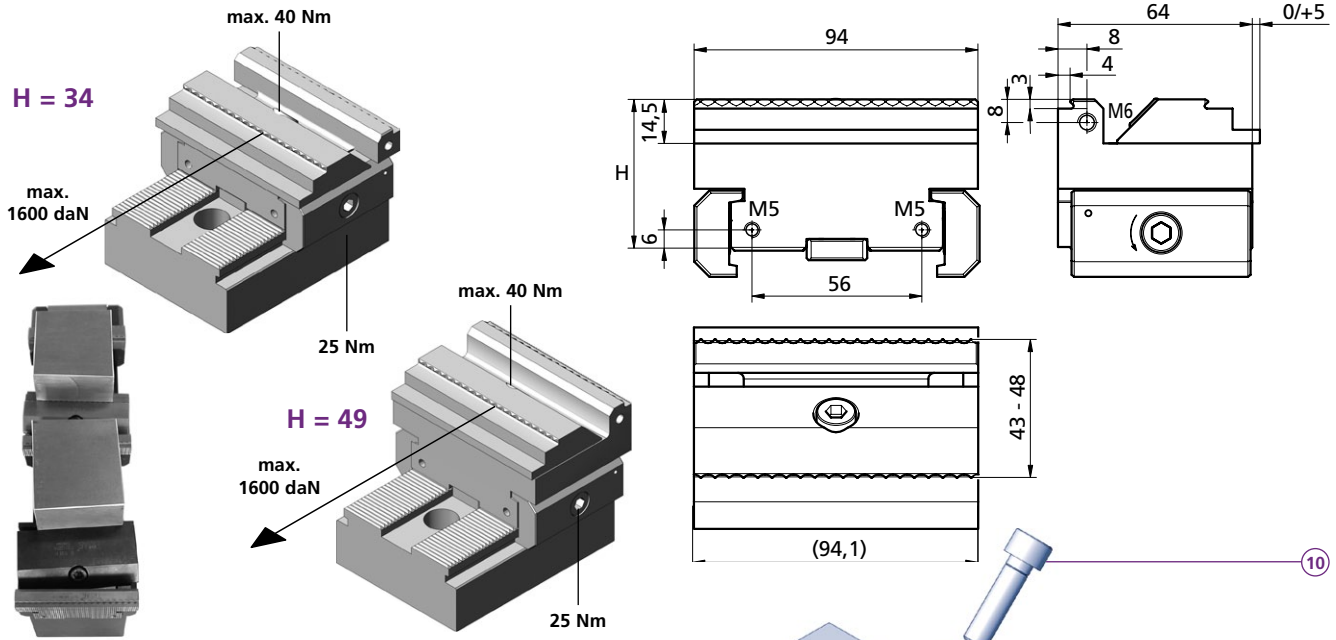

PS1P 94L34 -105

- 1 1x TW100100-01
 - 2 1x _____
 - 3 1x PCSP 60R
 - 4 1x PCSP 60L
 - 5 1x PCS 14
 - 6 1x PCGU 20 59
 - 7 1x M6x8 ISO 7380
 - 8 2x M5x14 ISO 4762
 - 9 2x PCD 005
 - 10 1x M8x30 ISO 4762
 - 11 1x PCUSR 14
 - 12 2x M5x10 ISO 4762
 - 13 1x PCKMR 45 M8
 - 14 2x D=6 DIN 5401
- H = 34
kg ~1,06

PS1P6 94L34 -105

- 1 1x TW100100-02
- kg ~1,06

PS1P 94L49 -105

- 1 1x TK120857
 - 15 1x PCD 20L15
- H = 49
kg ~1,3

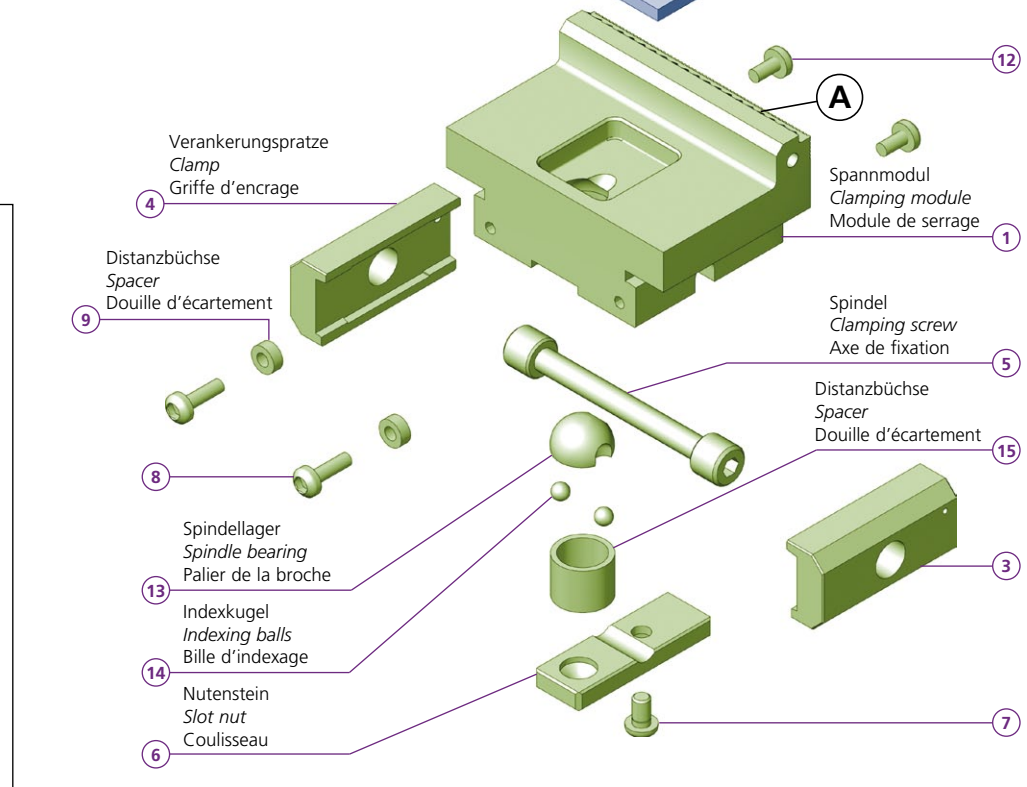

p. 96

Bestellbeispiel / Ordering example / Exemple de commande:
1x PS1P 94L34 -105 & 1x B115

PS1PF 94L49 -105

- 1 1x TK140783
 - 15 1x PCD 20L15
- H = 49
kg ~1,3

PS1PF 94L34 -105

- 1 1x TK140782
- H = 49
kg ~1,06

Drehmoment Torque Couple de torsion	Spannkraft Workholding force Force de serrage
10 Nm lb-ft 7,4	= 0,4 t 400 daN
20 Nm lb-ft 14,8	= 0,8 t 800 daN
30 Nm lb-ft 22,2	= 1,2 t 1200 daN
40 Nm lb-ft 29,6	= 1,6 t 1600 daN

Separat bestellen / Separate order / Commander séparément



PS1PV 48L34 -105

powerCLAMP

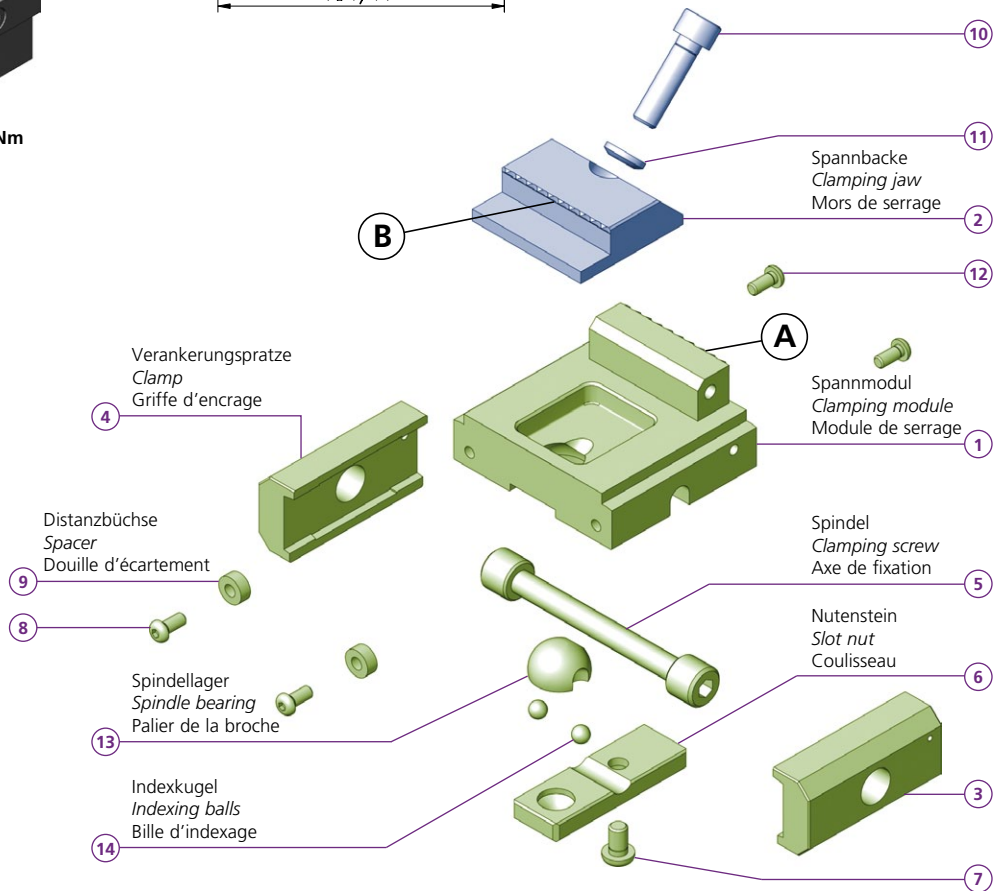
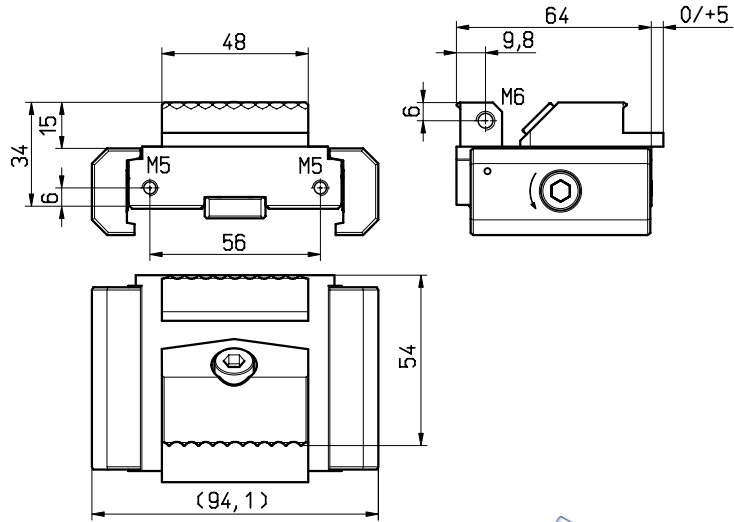
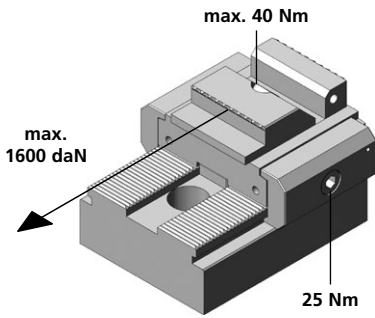

PS1PV 48L34 -105

- 1 1x TK140762
- 2 1x
- 3 1x PCSP 60R
- 4 1x PCSP 60L
- 5 1x PCS 14
- 6 1x PCGU 20 59
- 7 1x M6x8 ISO 7380
- 8 2x M5x14 ISO 4762
- 9 2x PCD 005
- 10 1x M8x28 ISO 4762
- 11 1x PCUSR 16
- 12 2x M5x10 ISO 4762
- 13 1x PCKMR 45 M8
- 14 2x D=6 DIN 5401

kg ~1,0

Bestellbeispiel / Ordering example / Exemple de commande:
1x PS1PV 48L34 -105 & 1x B123P

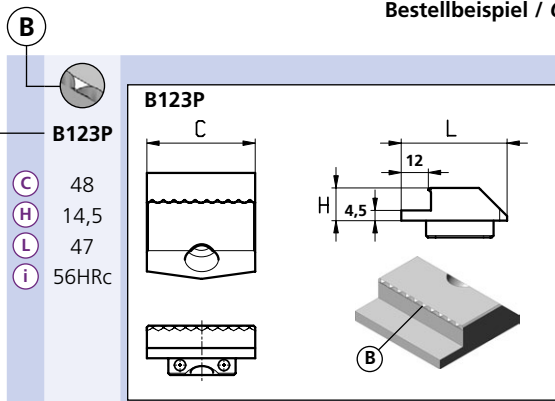

Drehmoment Torque Couple de torsion	Spannkraft Workholding force Force de serrage
10 Nm lb-ft 7,4	= 0,4 t 400 daN
20 Nm lb-ft 14,8	= 0,8 t 800 daN
30 Nm lb-ft 22,2	= 1,2 t 1200 daN
40 Nm lb-ft 29,6	= 1,6 t 1600 daN

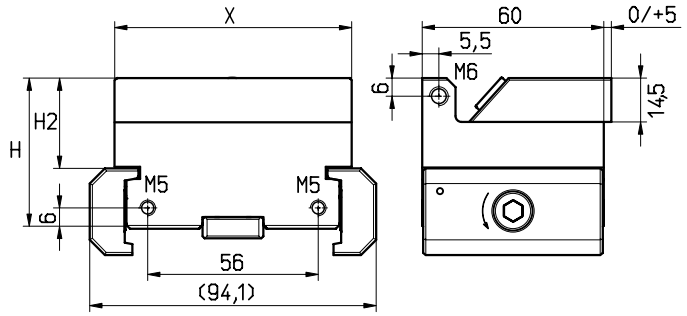
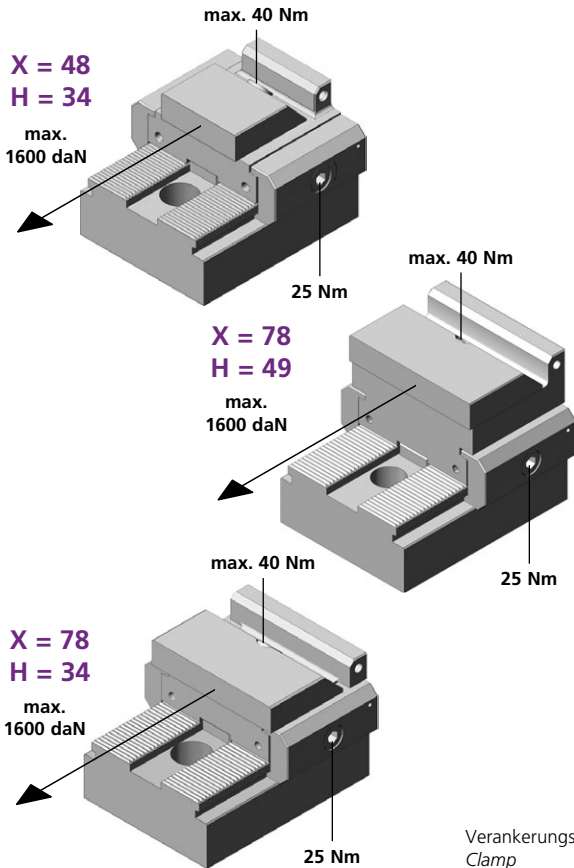

PS1R 48L34 -105	
1	1x T00120
PS1F 48L34 -105	
1	1x TW090122-01
2	1x
3	1x PCSP 60R
4	1x PCSP 60L
5	1x PCS 14
6	1x PCGU 20 59
7	1x M6x8 ISO 7380
8	2x M5x14 ISO 4762
9	2x PCD 005
10	1x M8x30 ISO 4762
11	1x PCUSR 14
12	2x M5x10 ISO 4762
13	1x PCKMR 45 M8
14	2x D=6 DIN 5401
X	= 48
H	= 34
H2	= 15
kg	~1,2

PS1R 78L34 -105	
1	1x TF140575
PS1F 78L34 -105	
1	1x TF140574
X	= 78
H	= 34
H2	= 15
kg	~1,0

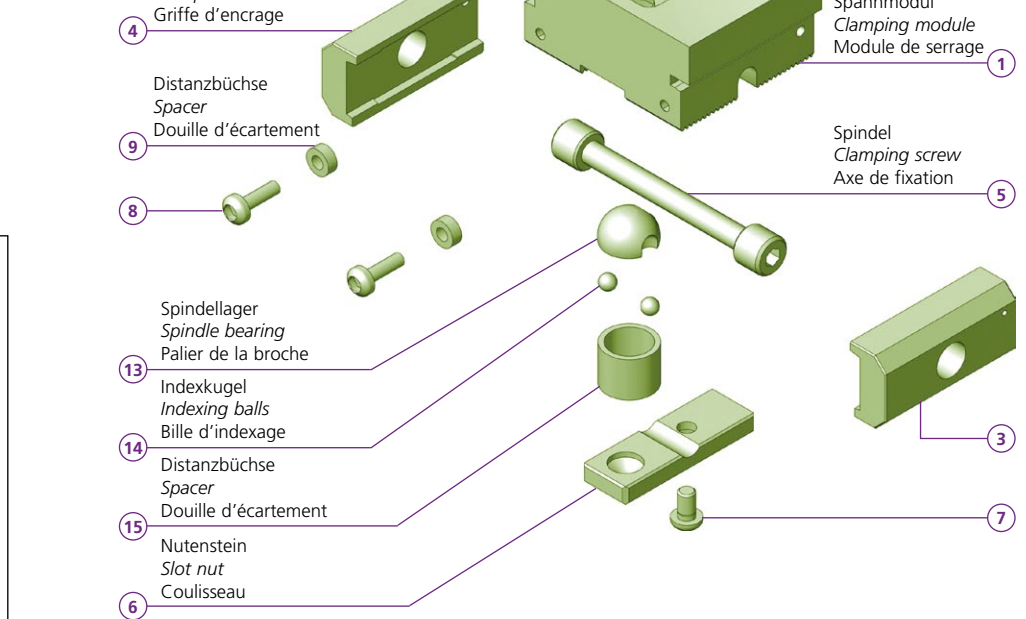

PS1R 78L49 -105	
1	1x TK110399
15	2x PCD 20L15
PS1F 78L49 -105	
1	1x TK110400
15	2x PCD 20L15
X	= 78
H	= 49
H2	= 30
kg	~1,5

p. 96

Bestellbeispiel / Ordering example / Exemple de commande:
1x PS1R 48L34 -105 & 1x B105

Drehmoment Torque Couple de torsion	Spannkraft Workholding force Force de serrage
10 Nm	lb-ft 7,4 = 0,4 t 400 daN
20 Nm	lb-ft 14,8 = 0,8 t 800 daN
30 Nm	lb-ft 22,2 = 1,2 t 1200 daN
40 Nm	lb-ft 29,6 = 1,6 t 1600 daN

Separat bestellen / Separate order / Commander séparément

PS1PV 94L34 -105
PS1PV 94L49 -105

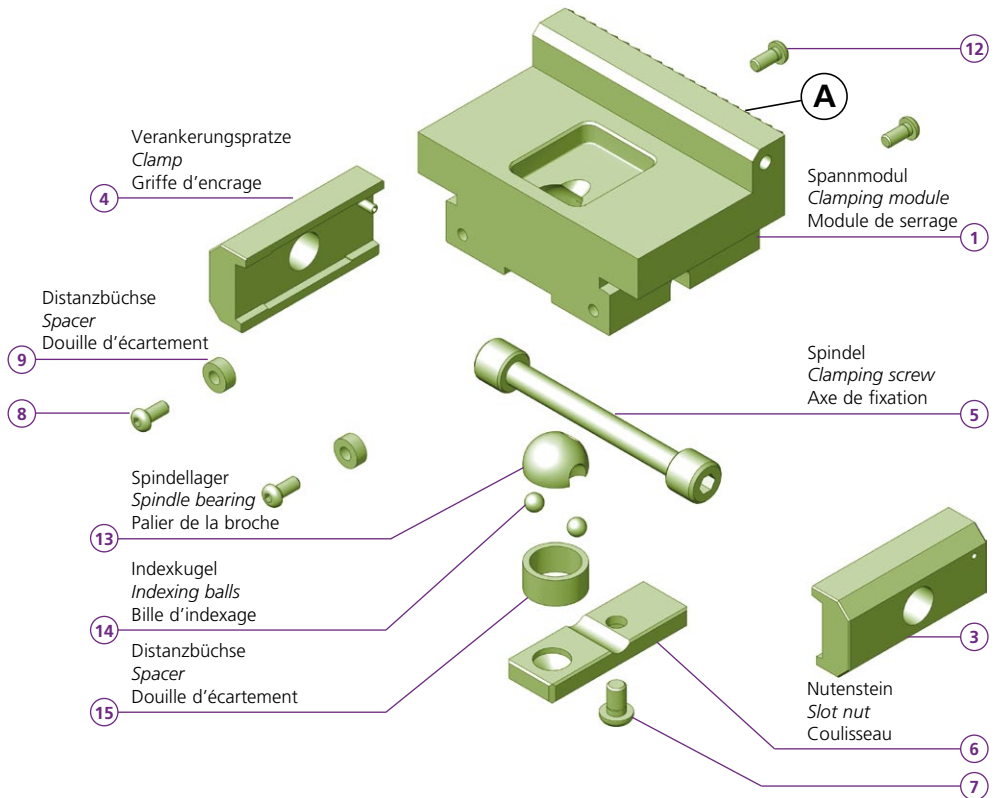
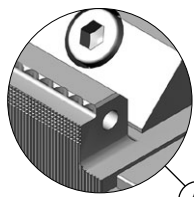
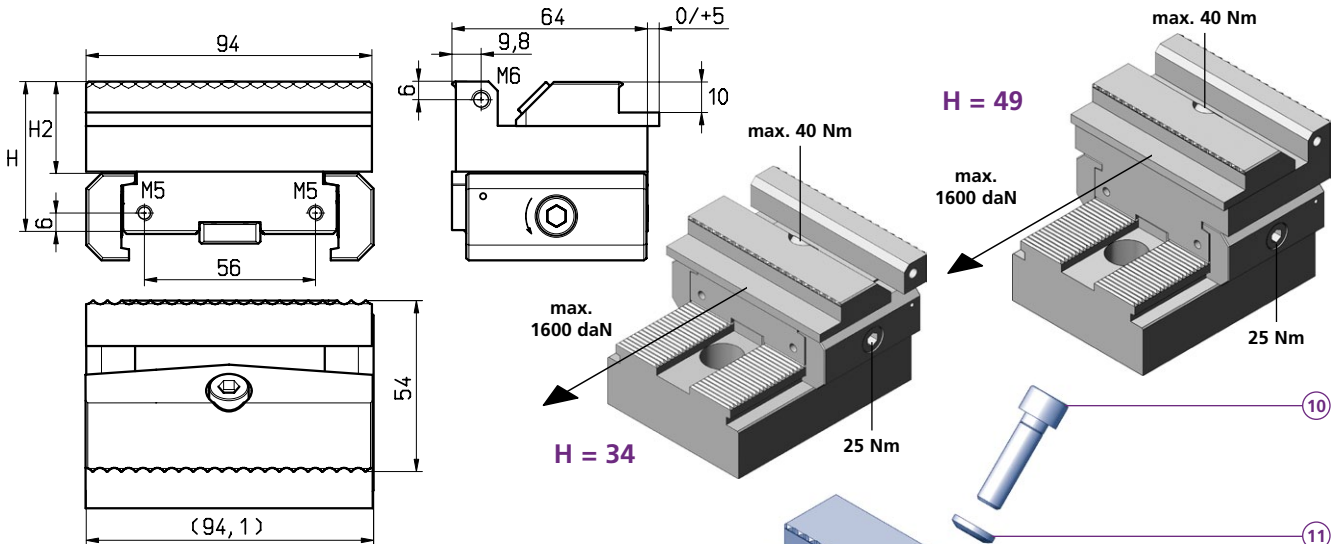

PS1PV 94L34 -105

- 1 1x TK120230
- 2 1x
- 3 1x PCSP 60R
- 4 1x PCSP 60L
- 5 1x PCS 14
- 6 1x PCGU 20 59
- 7 1x M6x8 ISO 7380
- 8 2x M5x14 ISO 4762
- 9 2x PCD 005
- 10 1x M8x28 ISO 4762
- 11 1x PCUSR 16
- 12 2x M5x10 ISO 4762
- 13 1x PCKMR 45 M8
- 14 2x D=6 DIN 5401
- H = 34
- H2 = 15
- kg ~1,05

PS1PV 94L49 -105

- 1 1x TK110250
- 15 1x PCD 20L15
- H = 49
- H2 = 30
- kg ~1,72

Bestellbeispiel / Ordering example / Exemple de commande:
1x PS1PV 94L49 -105 & 1x B122P

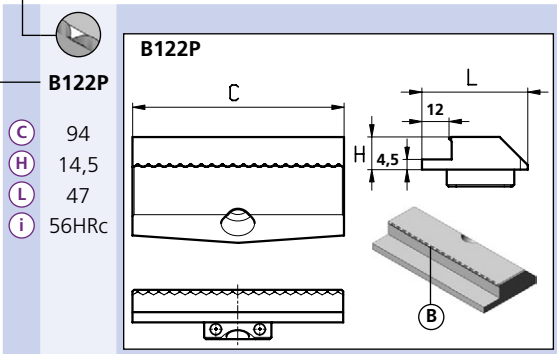

Drehmoment Torque Couple de torsion	Spannkraft Workholding force Force de serrage
10 Nm lb-ft 7,4	= 0,4 t 400 daN
20 Nm lb-ft 14,8	= 0,8 t 800 daN
30 Nm lb-ft 22,2	= 1,2 t 1200 daN
40 Nm lb-ft 29,6	= 1,6 t 1600 daN

Separat bestellen / Separate order / Commander séparément

PS1R/F 48L49 -105
PS5X 48L49 -105

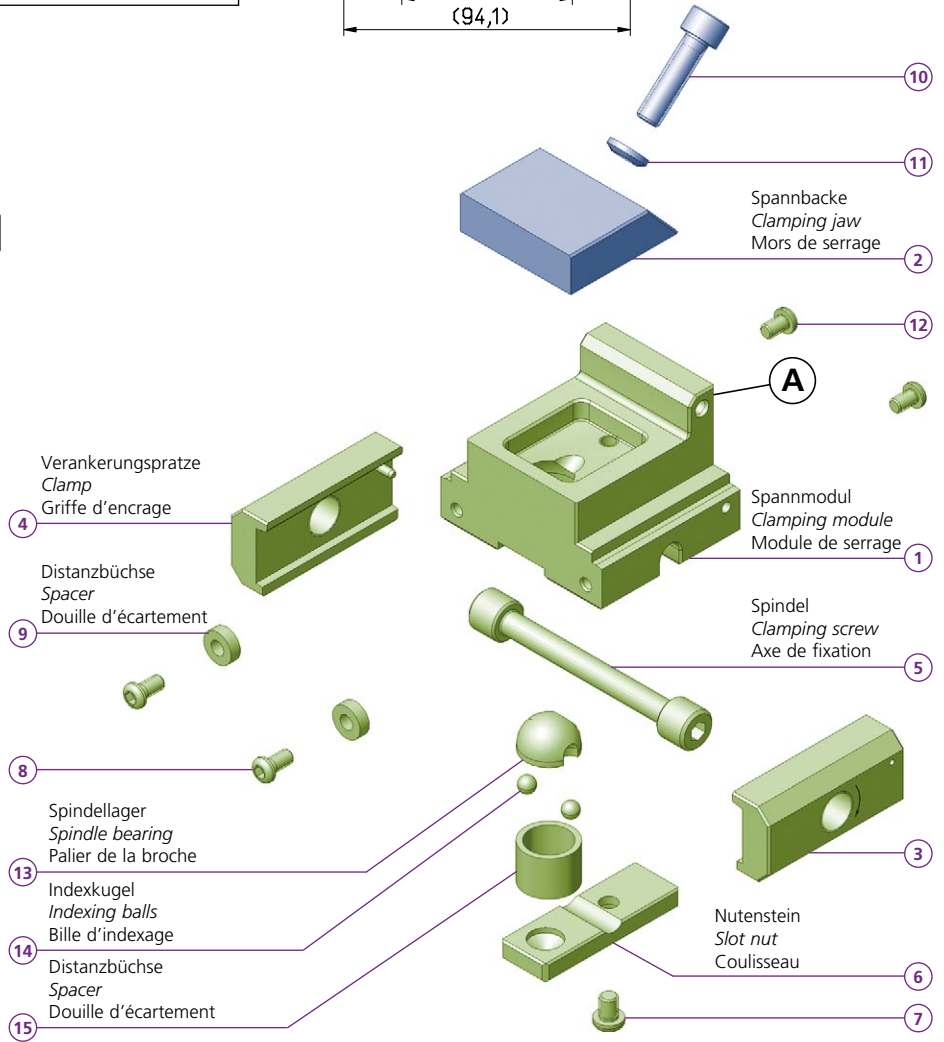
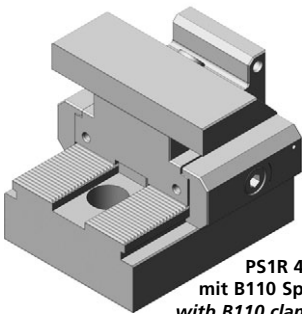
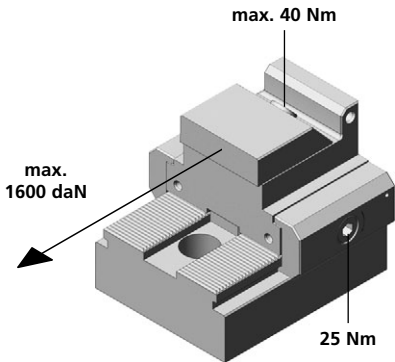
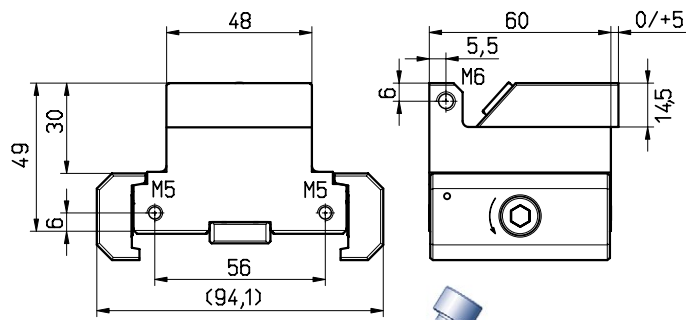
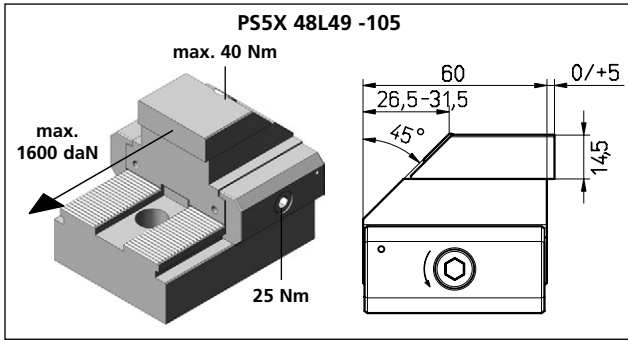

PS5X 48L49 -105	
1	1x TW090120
PS1F 48L49 -105	
1	1x TF140673
PS1R 48L49 -105	
1	1x TF140672
2	1x
3	1x PCSP 60R
4	1x PCSP 60L
5	1x PCS 14
6	1x PCGU 20 59
7	1x M6x8 ISO 7380
8	2x M5x14 ISO 4762
9	2x PCD 005
10	1x M8x30 ISO 4762
11	1x PCUSR 14
12	2x M5x10 ISO 4762
13	1x PCKMR 45 M8
14	2x D=6 DIN 5401
15	1x PCD 20L15
kg	~1,5

p. 96

Bestellbeispiel / Ordering example / Exemple de commande:
 1x PS1F 48L49 -105 & 1x B105



Drehmoment Torque Couple de torsion	Spannkraft Workholding force Force de serrage
10 Nm	lb-ft 7,4 = 0,4 t 400 daN
20 Nm	lb-ft 14,8 = 0,8 t 800 daN
30 Nm	lb-ft 22,2 = 1,2 t 1200 daN
40 Nm	lb-ft 29,6 = 1,6 t 1600 daN

Separat bestellen / Separate order / Commander séparément



PS5X 48L34 -105

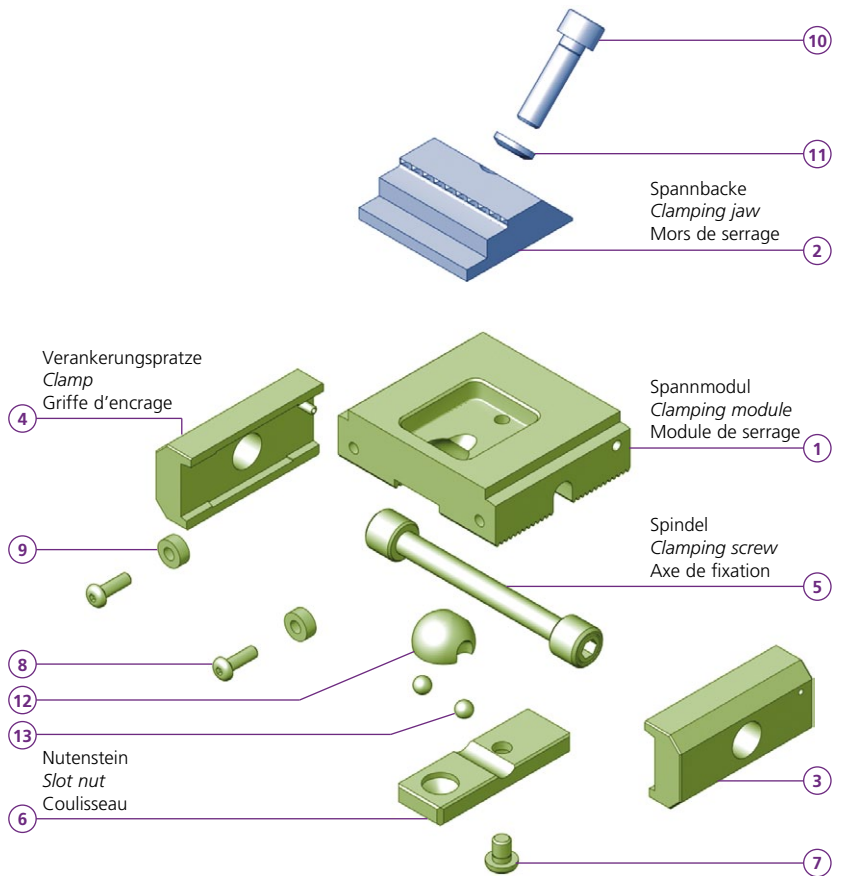
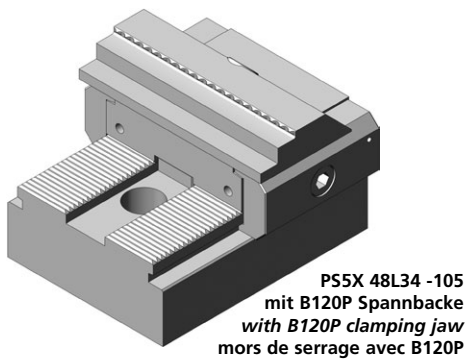
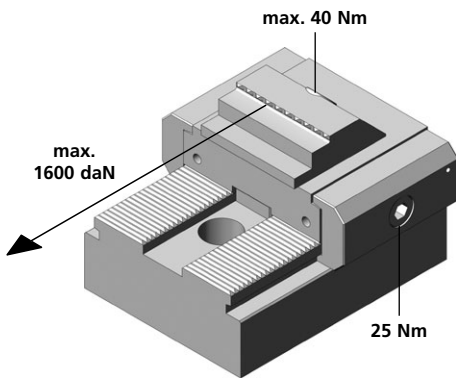
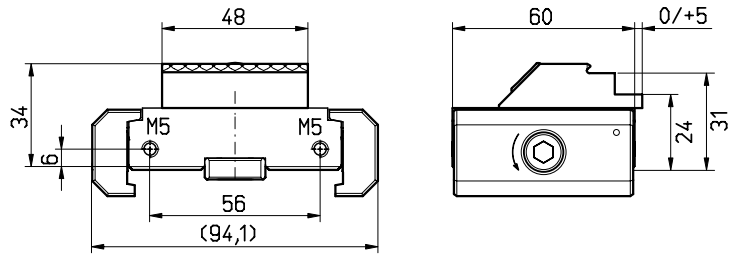

PS5X 48L34 -105	
1	1x T00365
2	1x
3	1x PCSP 60R
4	1x PCSP 60L
5	1x PCS 14
6	1x PCGU 20 59
7	1x M6x8 ISO 7380
8	2x M5x14 ISO 4762
9	2x PCD 005
10	1x M8x30 ISO 4762
11	1x PCUSR 14
12	1x PCKMR 45 M8
13	2x D=6 DIN 5401
kg	~0,48

p. 96

Bestellbeispiel / Ordering example / Exemple de commande:
1x PS5X 48L34 -105 & 1x B105

Drehmoment Torque Couple de torsion	Spannkraft Workholding force Force de serrage
10 Nm lb-ft 7,4	= 0,4 t 400 daN
20 Nm lb-ft 14,8	= 0,8 t 800 daN
30 Nm lb-ft 22,2	= 1,2 t 1200 daN
40 Nm lb-ft 29,6	= 1,6 t 1600 daN

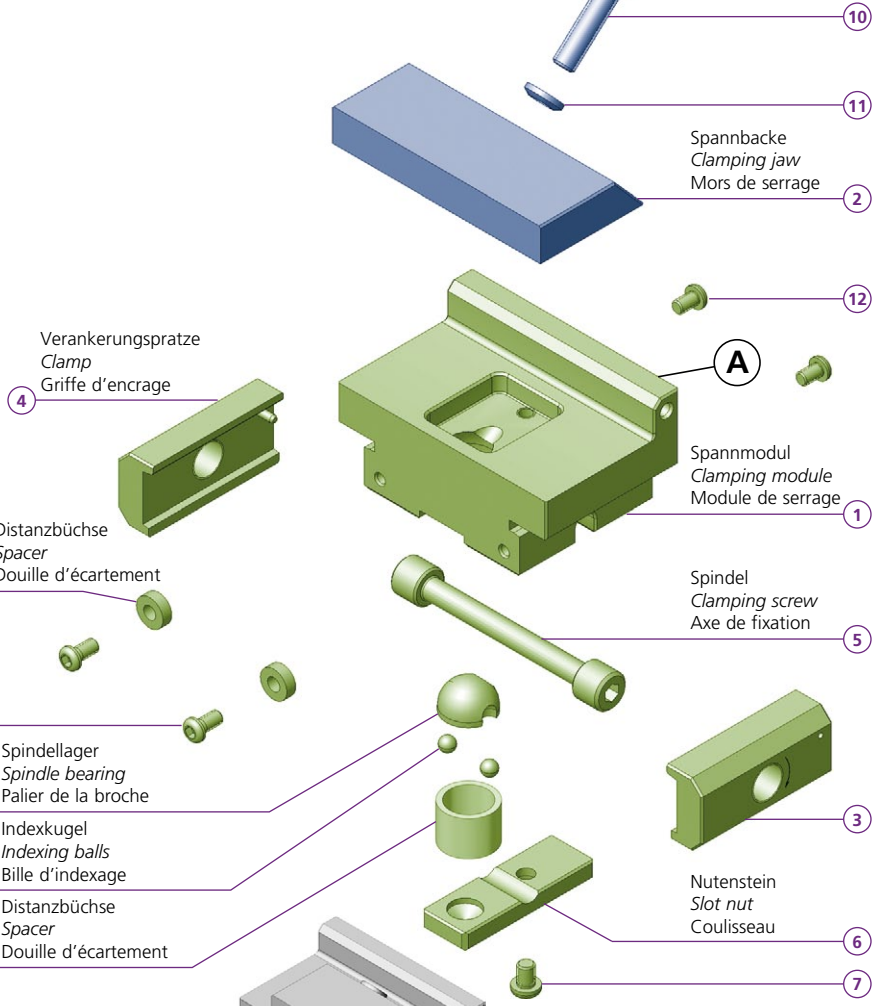
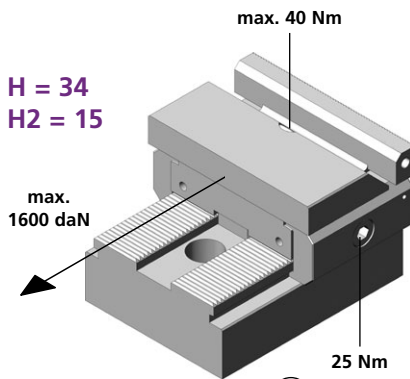
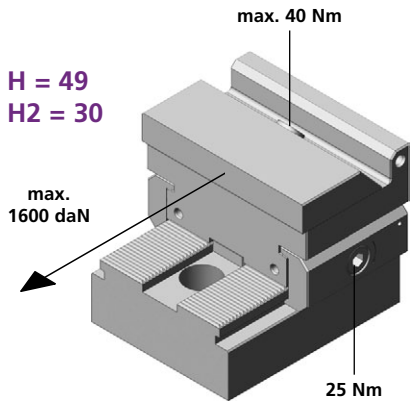
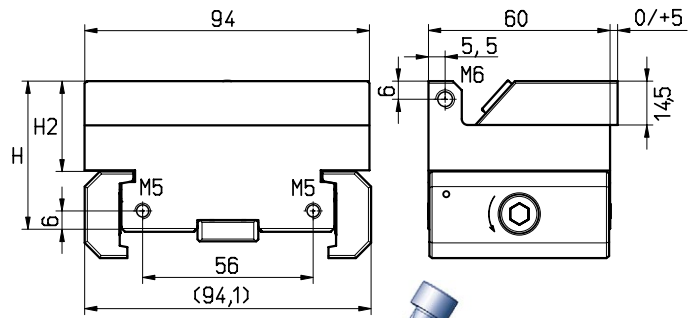
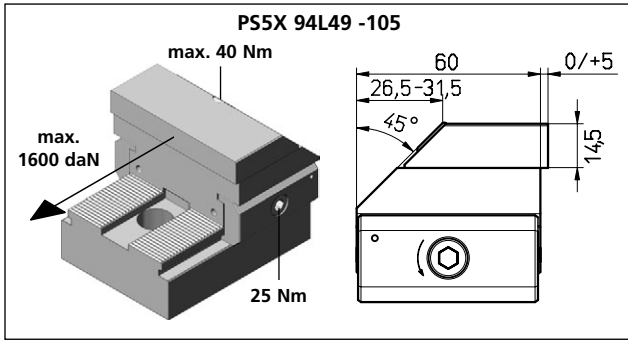

PS5X 94L49 -105

1x TW100186

2x PCD 20L15

PS1F 94L34 -105

1x TH130785

PS1R 94L34 -105

1x TH130786

1x

1x PCSP 60R

1x PCSP 60L

1x PCS 14

1x PCGU 20 59

1x M6x8 ISO 7380

2x M5x14 ISO 4762

2x PCD 005

1x M8x30 ISO 4762

1x PCUSR 14

2x M5x10 ISO 4762

1x PCKMR 45 M8

2x D=6 DIN 5401

H = 34

H2 = 15

kg ~1,0

p. 96

PS1F 94L49 -105

1x TF140674

2x PCD 20L15

PS1R 94L49 -105

1x TF140675

2x PCD 20L15

H = 49

H2 = 30

kg ~2,1

PS1R 94L49 -105 mit B105 Spannbacke
with B105 clamping jaw
mors de serrage avec B105

Bestellbeispiel / Ordering example / Exemple de commande:
1x PS1R 94L49 -105 & 1x B105

Drehmoment Torque Couple de torsion	Spannkraft Workholding force Force de serrage
10 Nm lb-ft 7,4	= 0,4 t 400 daN
20 Nm lb-ft 14,8	= 0,8 t 800 daN
30 Nm lb-ft 22,2	= 1,2 t 1200 daN
40 Nm lb-ft 29,6	= 1,6 t 1600 daN

Separat bestellen / Separate order / Commander séparément

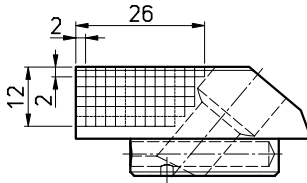

Zum Erstellen Ihrer individuellen Formbacke:
Schnittzeichnung zum Ermitteln der maximalen Bearbeitungsprofiltiefe

If a dedicated jaw is being machined:
This sketch will be of help regarding the workpiece penetration depth

Pour régler votre mors individuel aux étages:
Dessin en coupe pour déterminer la profondeur maximum du profil à usiner

für / for / pour B107, B112, B112E, 112HG

B105, B106, B107, B140, B141, B110, B111, B112, B112HG

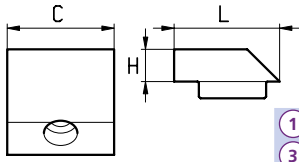

- 1 1x B...
- 3 1x M8x30 ISO 4762
- 4 1x PCUSR 14

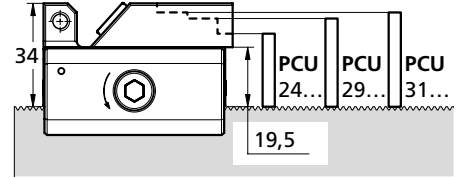
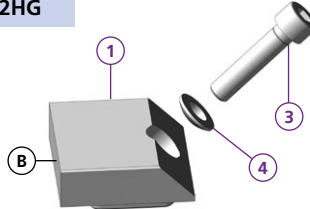

B108, B113

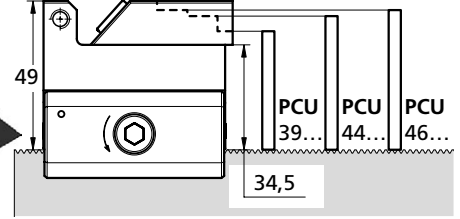
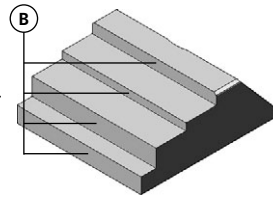
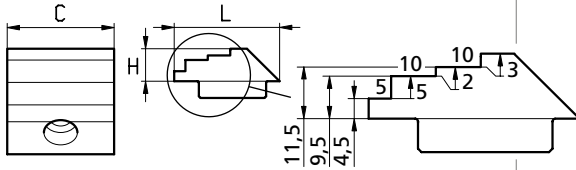

B115 P, B120 P, B115, B120

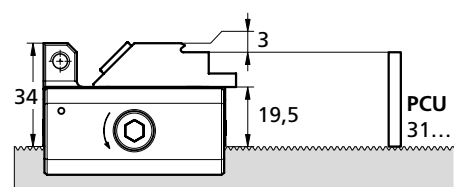
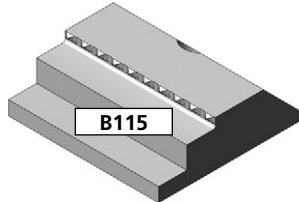
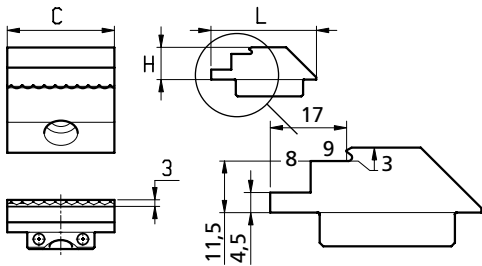

- 1 1x B115P, B120P
- 3 1x M8x28 ISO 4762
- 4 1x PCUSR 16

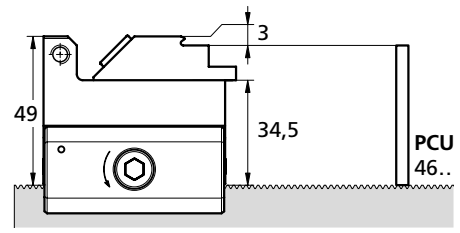
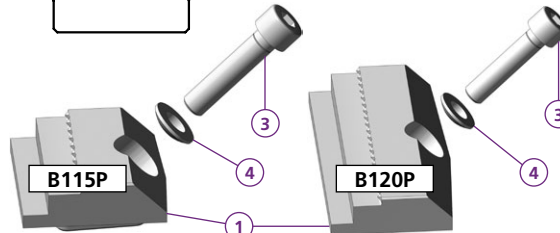

B105-15

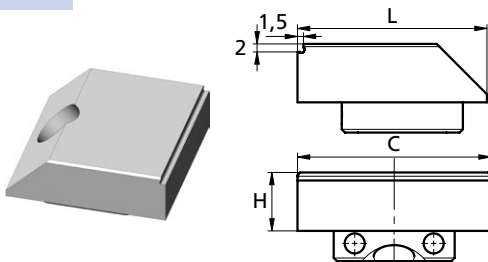

PF-SET

- 4 1x PCUSR 16
- 5 1x M8x35 ISO 4762
- 6 3x TH160577

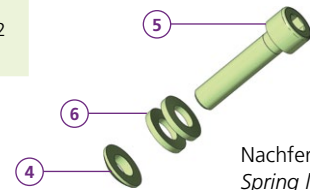

Nachfedern
Spring loaded
Effet amortisseur

	HG = Hochgenau / High-precision / Haute precision													
	B105	B105-15	B106	B107	B108	B140	B141	B110	B111	B112	B112E	B113	B115	B120
	B105P		B106P	B107P	B108P	B140P	B141P	B110P	B111P	B112P	B112EP	B113P	B115P	B120P
C	48	48	48	48	48	78	78	94	94	94	94	94	48	94
H	14,5	14,5	14,5	14,5	14,5	14,5	14,5	14,5	14,5	14,5	14,5	14,5	14,5	14,5
L	47	47	47	47	47	47	47	47	47	47	47	47	47	47
i	HV700 x0,2mm	HV700 x0,2mm	HV700 x0,2mm	*	HV700 x0,2mm	HV700 x0,2mm	HV700 x0,2mm	HV700 x0,2mm	HV700 x0,2mm	*	**	HV700 x0,2mm	57HRc	57HRc

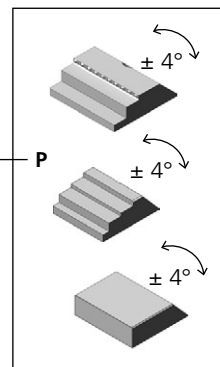

PS1R 48L49 -105H20
PS1R 94L49 -105H20

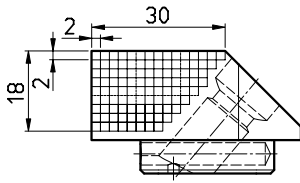

Zum Erstellen Ihrer individuellen Formbacke:
 Schnittzeichnung zum Ermitteln der maximalen Bearbeitungsprofiltiefe

If a dedicated jaw is being machined:
 This sketch will be of help regarding the workpiece penetration depth

Pour régler votre mors individuel aux étages:
 Dessin en coupe pour déterminer la profondeur maximum du profil à usiner

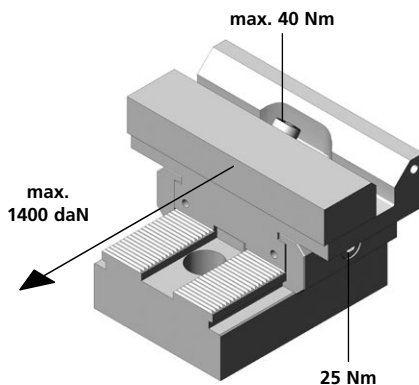
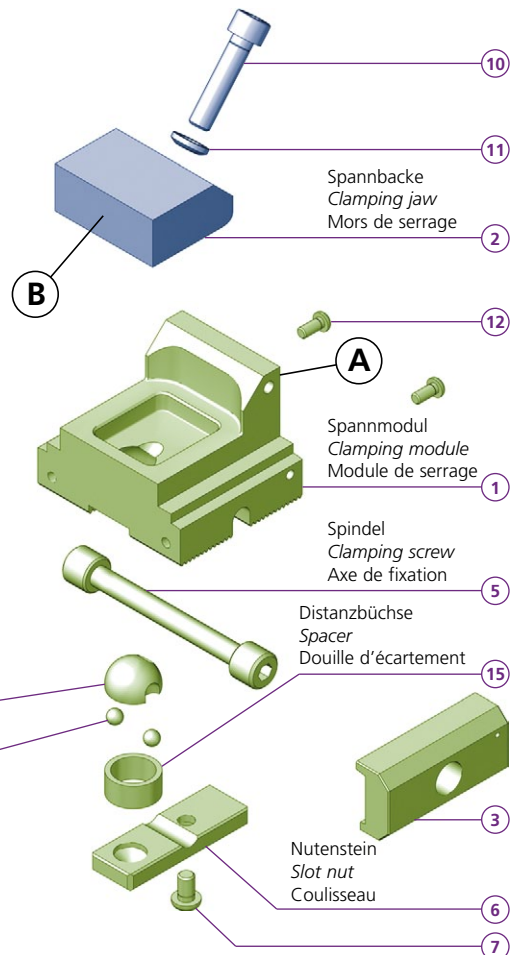
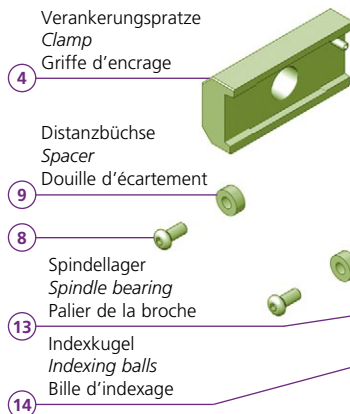
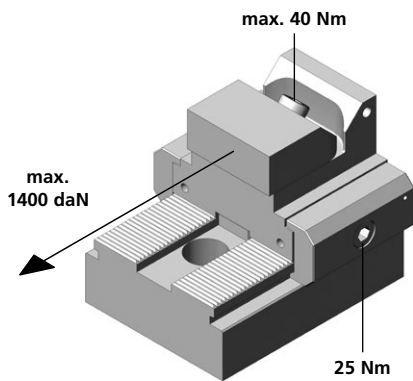
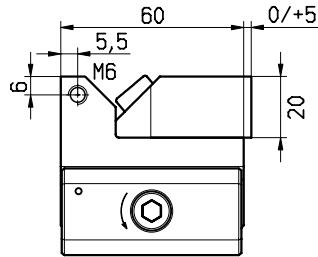
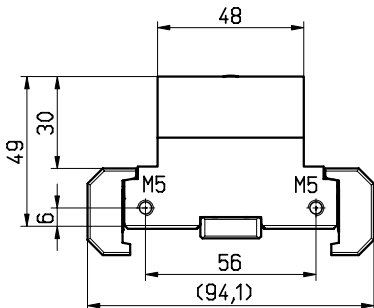

Drehmoment Torque Couple de torsion		Spannkraft Workholding force Force de serrage	
10 Nm	lb-ft 7,4	= 0,4 t	400 daN
20 Nm	lb-ft 14,8	= 0,8 t	800 daN
30 Nm	lb-ft 22,2	= 1,2 t	1200 daN
40 Nm	lb-ft 29,6	= 1,6 t	1600 daN

PS1R 48L49 -105H20

1	1x TW100161-01
2	1x
3	1x PCSP 60R
4	1x PCSP 60L
5	1x PCS 14
6	1x PCGU 20 59
7	1x M6x8 ISO 7380
8	2x M5x14 ISO 4762
9	2x PCD 005
10	1x M8x35 ISO 4762
11	1x PCUSR 14
12	2x M5x10 ISO 4762
13	1x PCKMR 51 M8
14	2x D=6 DIN 5401
15	1x PCD 20L 095

kg ~1,5

PS1R 94L49 -105H20

1	1x TW100161-07
---	----------------

kg ~2,1

Bestellbeispiel / Ordering example / Exemple de commande:
 1x **PS1R 48L49 -105H20** & 1x **B107H20**

	B105H20	B106H20	B107H20	B110H20	B111H20	B112H20
C	48	48	48	94	94	48
H	20	20	20	20	20	20
L	47	47	47	47	47	47
i	HV700 x0,2mm	HV700 x0,2mm	*	HV700 x0,2mm	HV700 x0,2mm	*

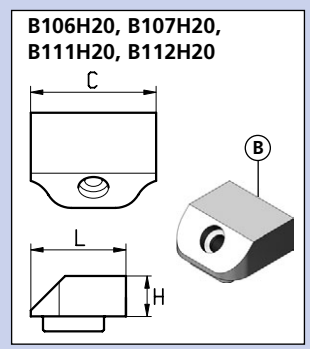

* = weich / soft / doux



PS1R 125L49 -105H20

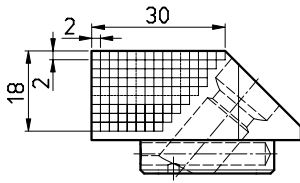

Zum Erstellen Ihrer individuellen Formbacke:
Schnittzeichnung zum Ermitteln der maximalen Bearbeitungsprofiltiefe

If a dedicated jaw is being machined:
This sketch will be of help regarding the workpiece penetration depth

Pour régler votre mors individuel aux étages:
Dessin en coupe pour déterminer la profondeur maximum du profil à usiner

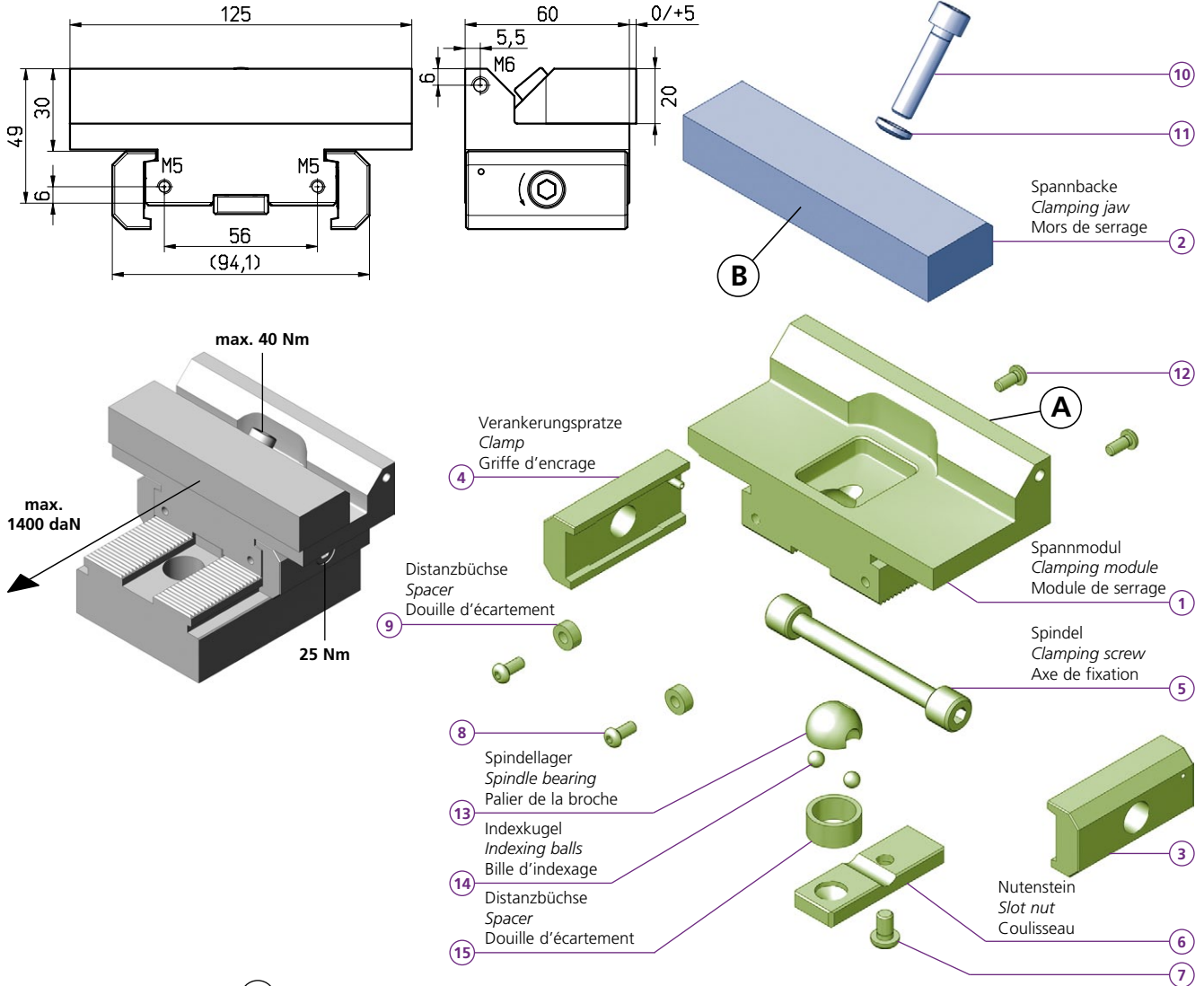

PS1R 125L49 -105H20	
1	1x TW110037
2	1x
3	1x PCSP 60R
4	1x PCSP 60L
5	1x PCS 14
6	1x PCGU 20 59
7	1x M6x8 ISO 7380
8	2x M5x14 ISO 4762
9	2x PCD 005
10	1x M8x35 ISO 4762
11	1x PCUSR 14
12	2x M5x10 ISO 4762
13	1x PCKMR 51 M8
14	2x D=6 DIN 5401
15	1x PCD 20L 095
kg	~2,5

Drehmoment Torque Couple de torsion	Spannkraft Workholding force Force de serrage
10 Nm lb-ft 7,4	= 0,4 t 400 daN
20 Nm lb-ft 14,8	= 0,8 t 800 daN
30 Nm lb-ft 22,2	= 1,2 t 1200 daN
40 Nm lb-ft 29,6	= 1,6 t 1600 daN

Bestellbeispiel / Ordering example / Exemple de commande:
1x PS1R 125L49 -105H20 & 1x B132H20P

	B130H20P	B131H20P	B132H20P
C	125	125	125
H	20	20	20
L	47	47	47
i	HV700 x0,2mm	HV700 x0,2mm	*

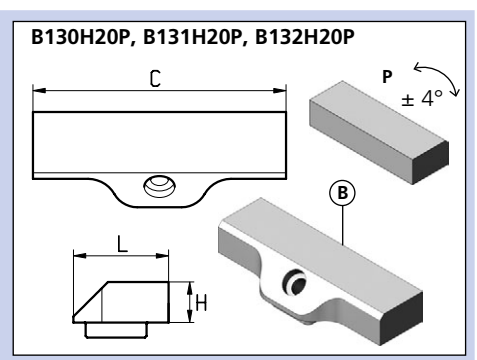

Separat bestellen / Separate order / Commander séparément

Anschlagmodule
End module
Module d'appui

PAND 19-49
PAND 26-49
PAND 34-49

PA5X 19-49 R/F
PA5X 26-49 R/F
PA5X 34-49 R/F

powerCLAMP

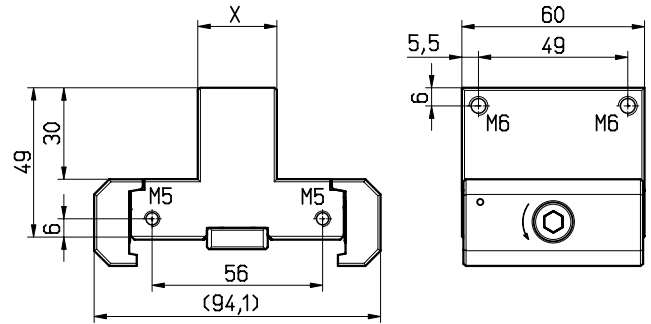
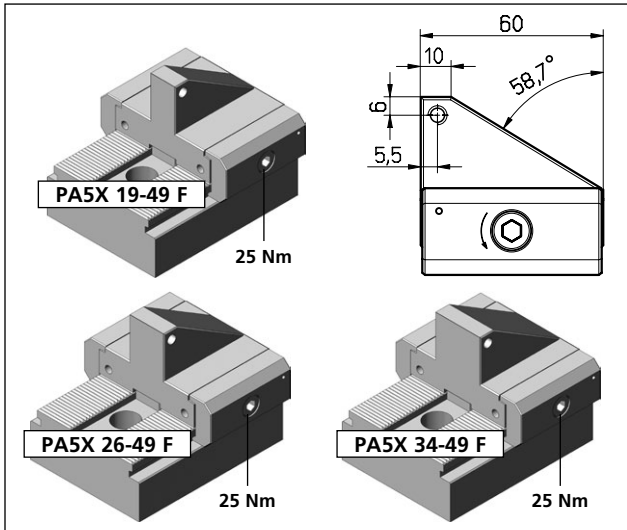

	PA5X 19-49 R	
	1x TF140617	
	2x M5x10 ISO 4762	
	PA5X 19-49 F	
	1x TF140618	
	PAND 19-49	
	1x TF140619	
	1x PCSP 60R	
	1x PCSP 60L	
	1x PCS 14	
	1x PCGU 20 49	
	1x M6x8 ISO 7380	
	4x M5x10 ISO 4762	
X	= 19	
kg	~1,1	

	PA5X 26-49 R	
	1x TF140621	
	2x M5x10 ISO 4762	
	PA5X 26-49 F	
	1x TF140620	
	2x M5x10 ISO 4762	
	PAND 26-49	
	1x TF140622	
X	= 26	
kg	~1,2	

	PA5X 34-49 R	
	1x TF14024	
	2x M5x10 ISO 4762	
	PA5X 34-49 F	
	1x TF14023	
	2x M5x10 ISO 4762	
	PAND 34-49	
	1x TF14025	
X	= 34	
kg	~1,3	

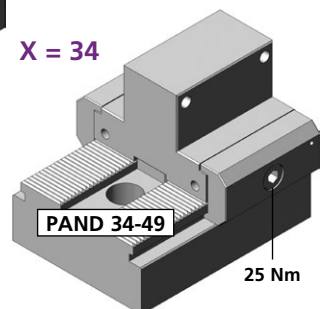
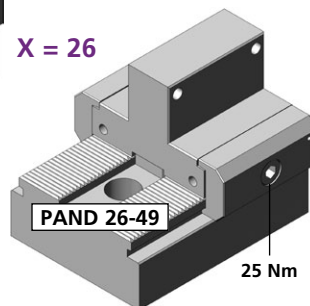
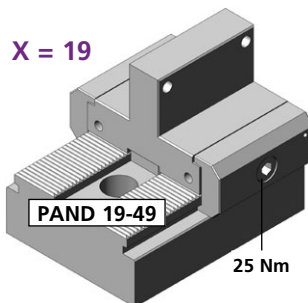
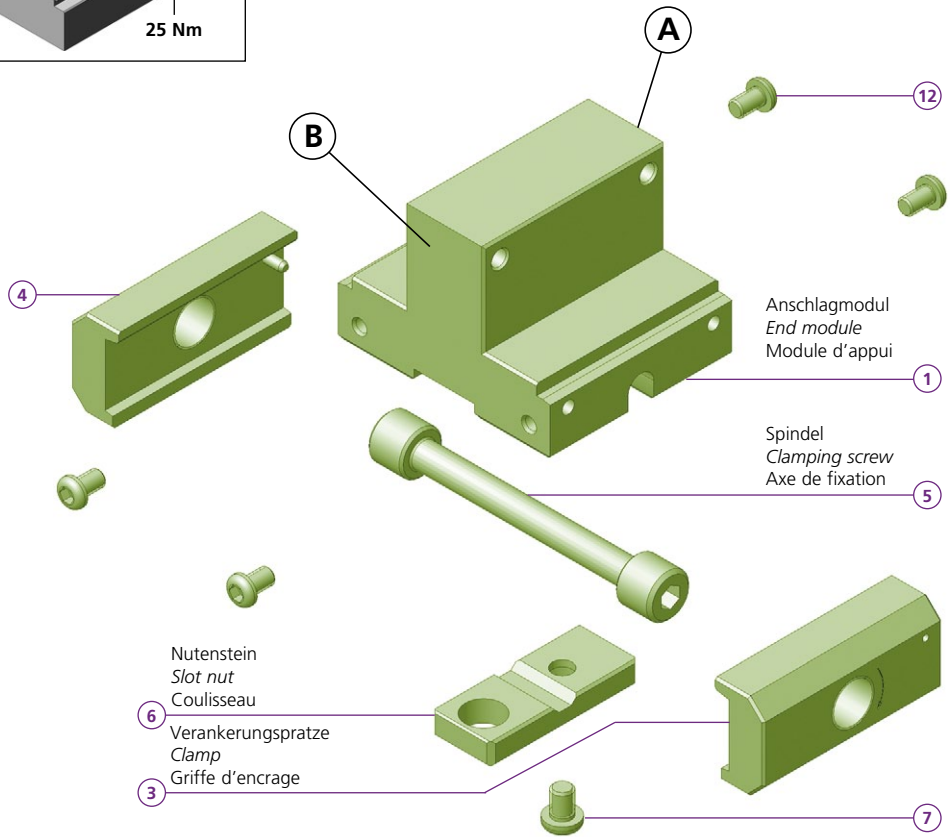

Bestellbeispiel / Ordering example / Exemple de commande: **PAND 19-49**



PAND 25-44

PAND 94-44

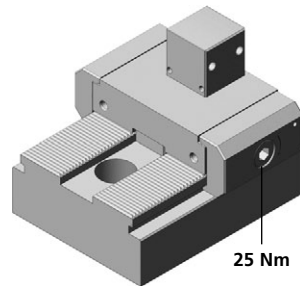
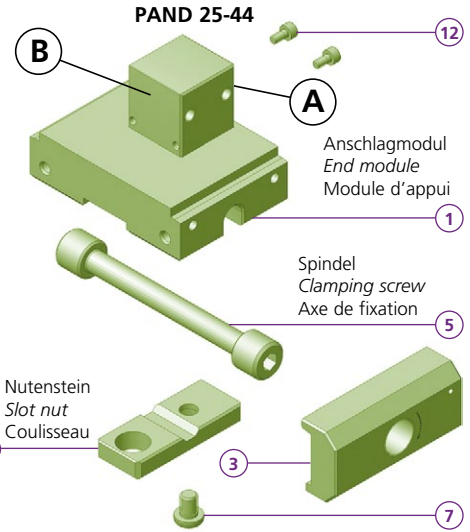
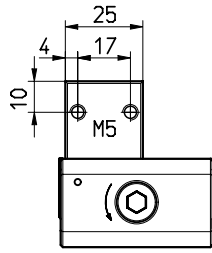
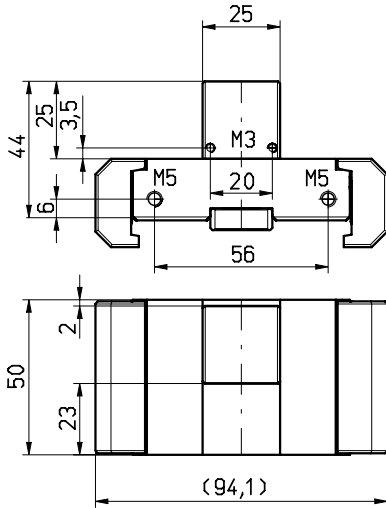

PAND 25-44

- | | |
|----|-------------------|
| 1 | 1x TF140626 |
| 3 | 1x PCSP 50R |
| 4 | 1x PCSP 50L |
| 5 | 1x PCS 14 |
| 6 | 1x PCGU 20 49 |
| 7 | 1x M6x8 ISO 7380 |
| 12 | 4x M5x10 ISO 4762 |
| kg | ~0,9 |

Bestellbeispiel / Ordering example / Exemple de commande: **PAND 25-44**

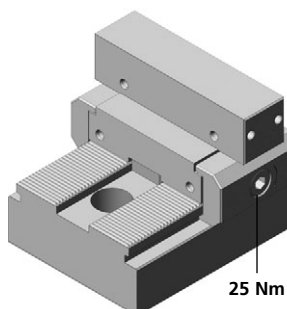
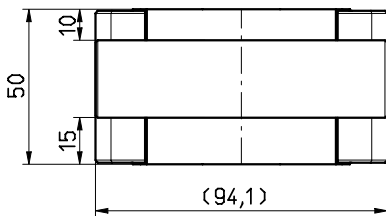
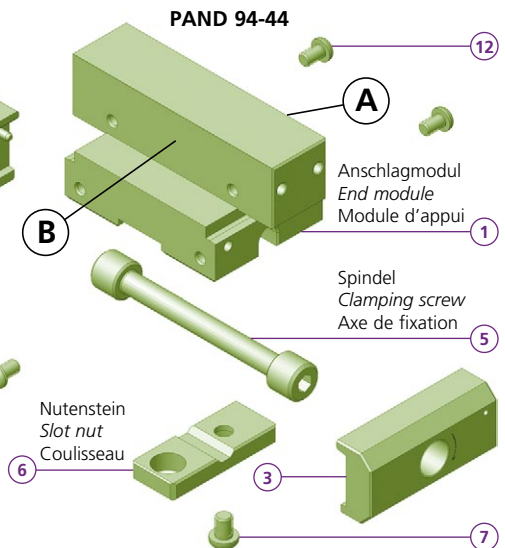
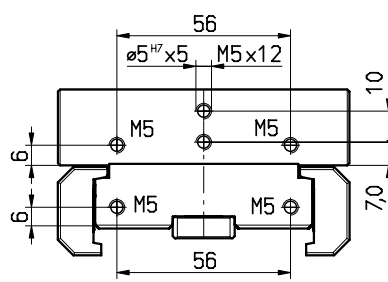
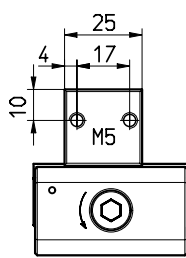
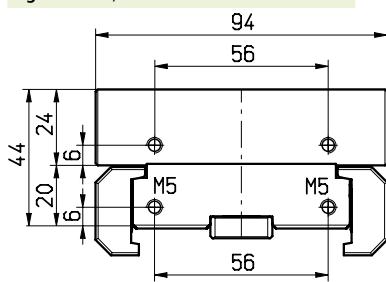

Bestellbeispiel / Ordering example / Exemple de commande: **PAND 94-44**

PAND 48-34

PAND 58-34

PAND 61-34

PAND 48-75

PAND 58-49



powerCLAMP

X = 48
H = 34

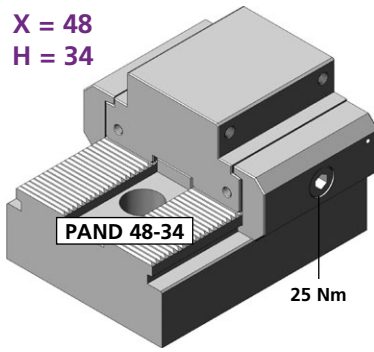

25 Nm

X = 48
H = 75

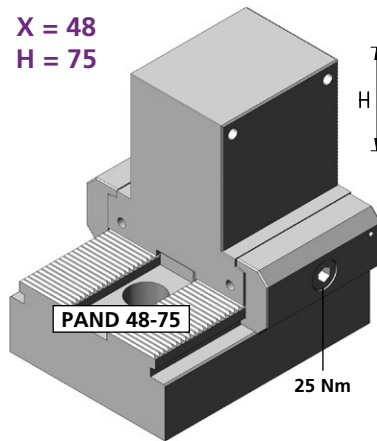

25 Nm

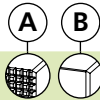
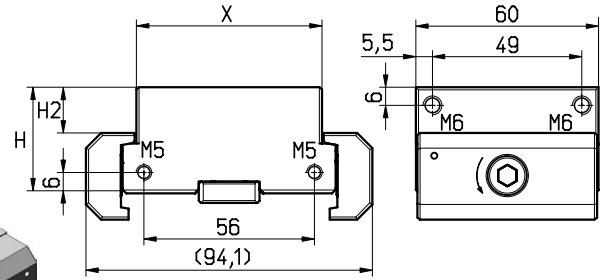

PAND 48-34

- 1 1x TF140628
 - 3 1x PCSP 60R
 - 4 1x PCSP 60L
 - 5 1x PCS 14
 - 6 1x PCGU 20 49
 - 7 1x M6x8 ISO 7380
 - 12 4x M5x10 ISO 4762
- X = 48
H = 34
H2 = 15
kg ~1,3

Verankerungspratze
Clamp
Griffe d'encrage

4

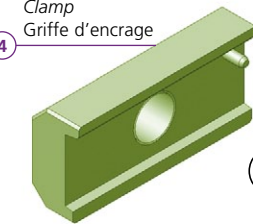

B

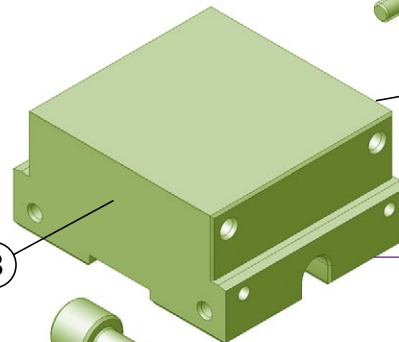

Anschlagmodul
End module
Module d'appui

1

Spindel
Clamping screw
Axe de fixation

5

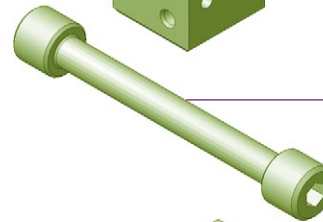

Nutenstein
Slot nut
Coulisseau

6



3

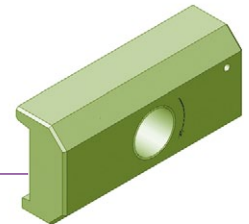

7

X = 58
H = 49

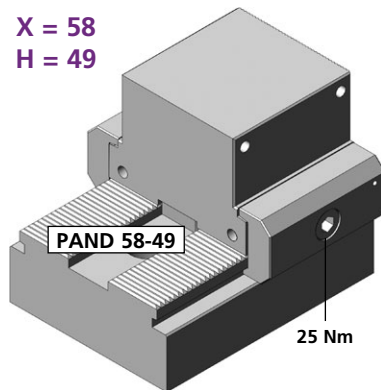

25 Nm

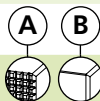

PAND 58-34

- 1 1x TF140629
- X = 58
H = 34
H2 = 15
kg ~1,4

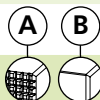

PAND 58-49

- 1 1x TK120130
- X = 58
H = 49
H2 = 30
kg ~1,72

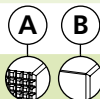

PAND 61-34

- 1 1x TF140630
- X = 61
H = 34
H2 = 15
kg ~1,4

X = 58
H = 34

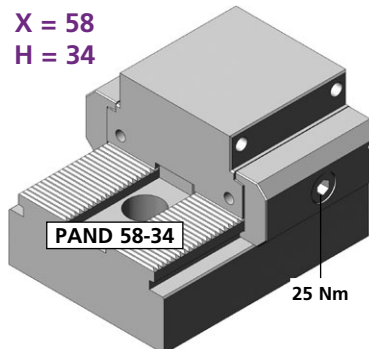

25 Nm

X = 61
H = 34

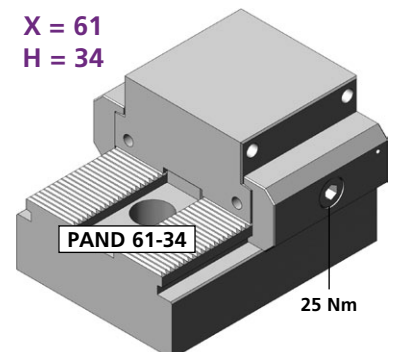

25 Nm

Bestellbeispiel / Ordering example / Exemple de commande: PAND 61-34

PAND 68-34

PAND 78-34

PAND 94-34

PAND 78-49



powerCLAMP

X = 68
H = 34

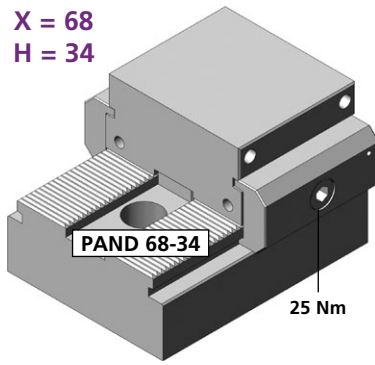

25 Nm

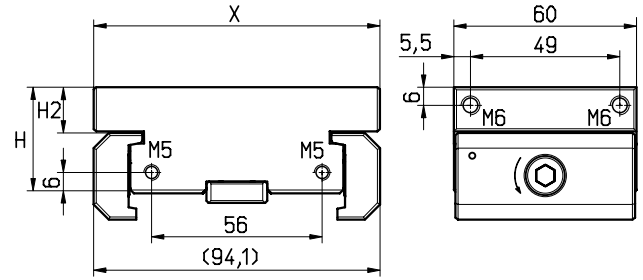

X = 78
H = 34

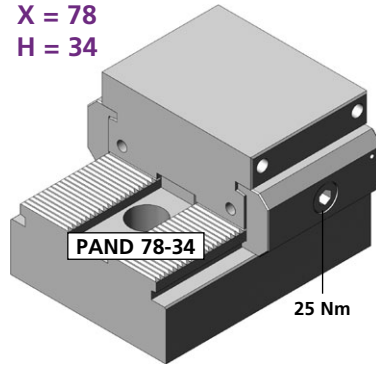

25 Nm

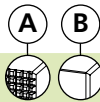

PAND 68-34

- 1 1x TF140631
 - 3 1x PCSP 60R
 - 4 1x PCSP 60L
 - 5 1x PCS 14
 - 6 1x PCGU 20 49
 - 7 1x M6x8 ISO 7380
 - 12 4x M5x10 ISO 4762
- X = 68
H = 34
H2 = 15
kg ~1,4

Verankerungspratze
Clamp
Griffe d'encrage

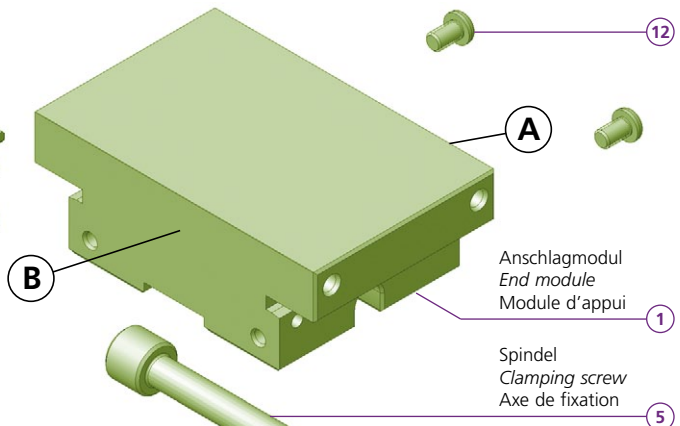
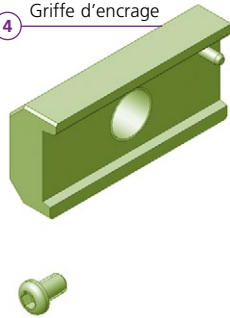

Ansschlagmodule
End module
Module d'appui

1

Spindel
Clamping screw
Axe de fixation

5

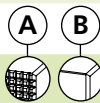

PAND 78-34

- 1 1x TF140632
- X = 78
H = 34
H2 = 15
kg ~1,5

Nutenstein
Slot nut
Coulisseau

6

3

7

X = 78
H = 49

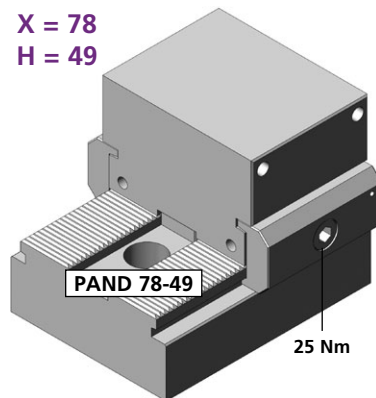

25 Nm

X = 94
H = 34

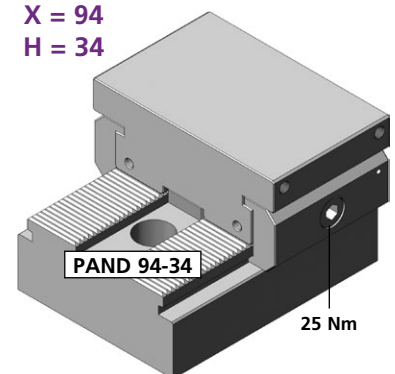

25 Nm

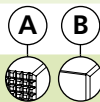

PAND 78-49

- 1 1x TF140634
- X = 78
H = 49
H2 = 30
kg ~2,0

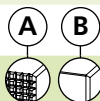

PAND 94-34

- 1 1x TF140633
- X = 94
H = 34
H2 = 15
kg ~1,6

Bestellbeispiel / Ordering example / Exemple de commande: PAND 94-34

PAND 43-49

PAND 125-49

PA5X 94-49 R/F

PAND 48-49

PA5X 43-49 R/F

PA5X 125-49 R/F

PAND 94-49

PA5X 48-49 R/F



powerCLAMP

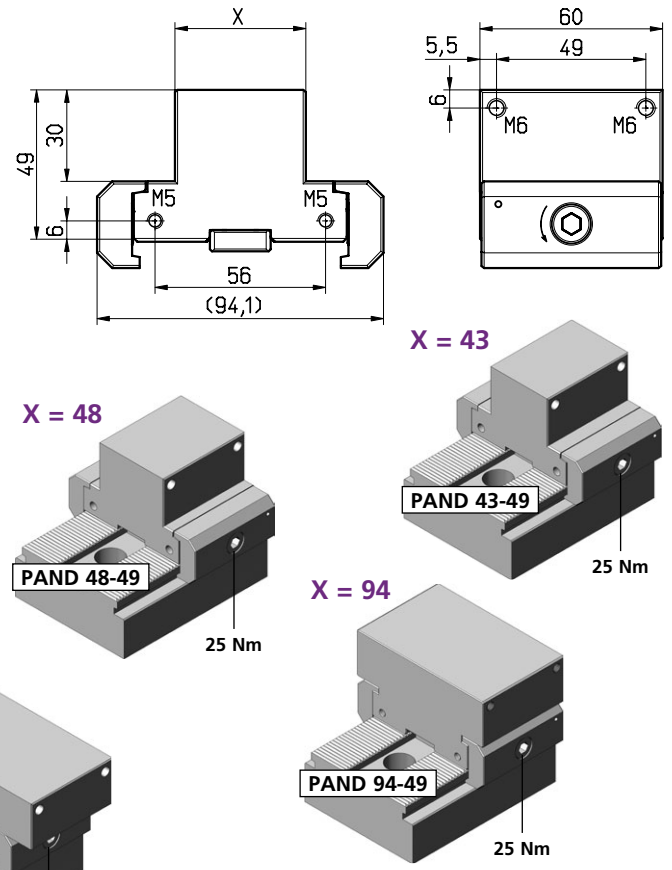
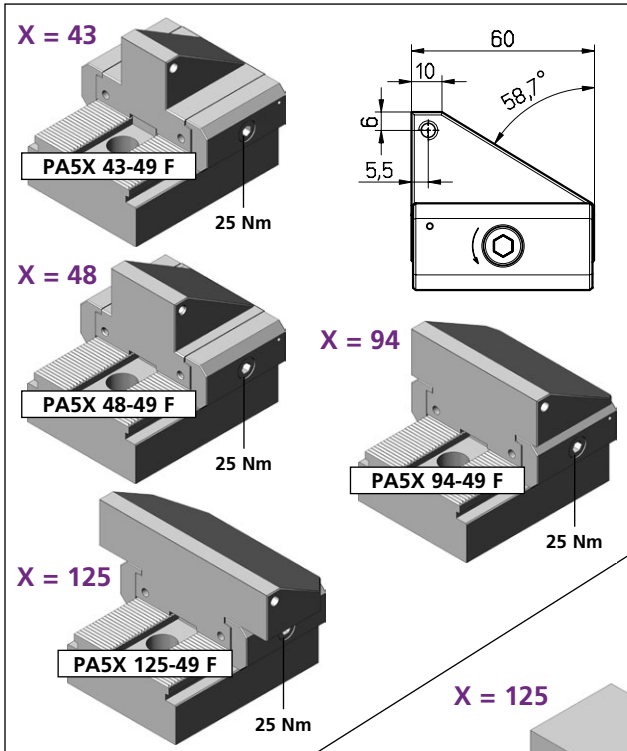

- PA5X 43-49 R**
 - 1x TF140651
 - 2x M5x10 ISO 4762
- PA5X 43-49 F**
 - 1x TF140652
- PAND 43-49**
 - 1x TF140659
 - 3x PCSP 60R
 - 4x PCSP 60L
 - 1x PCS 14
 - 1x PCGU 20 49
 - 1x M6x8 ISO 7380
 - 4x M5x10 ISO 4762
- X = 43
- kg ~1,5

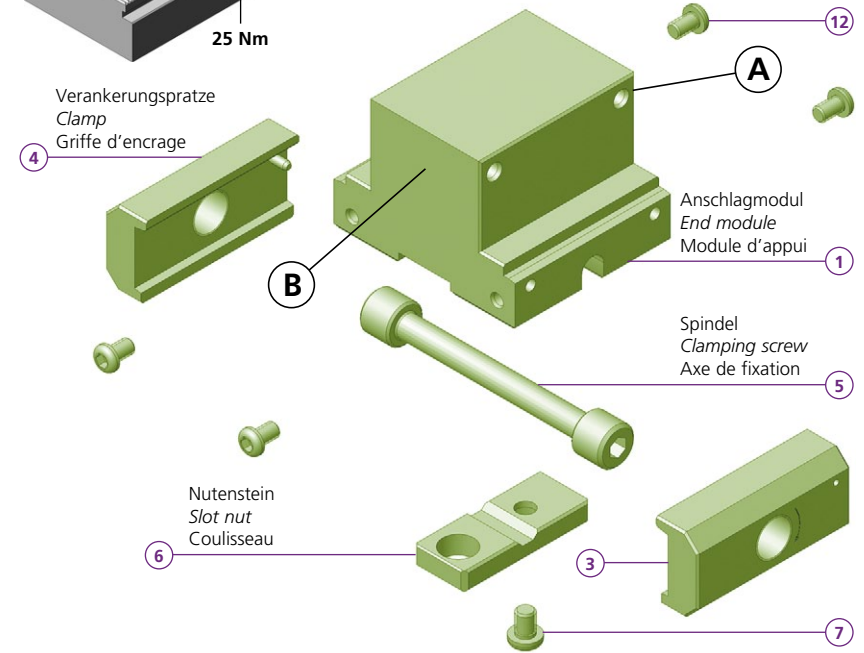

Bestellbeispiel / Ordering example / Exemple de commande: PAND 43-49

- PA5X 48-49 R**
 - 1x TF140653
- PA5X 48-49 F**
 - 1x TF140654
- PAND 48-49**
 - 1x TF140660
- X = 48
- kg ~1,6

- PA5X 94-49 R**
 - 1x TF140655
- PA5X 94-49 F**
 - 1x TF140656
- PAND 94-49**
 - 1x TF140661
- X = 94
- kg ~2,0

- PA5X 125-49 R**
 - 1x TF140657
- PA5X 125-49 F**
 - 1x TF140658
- PAND 125-49**
 - 1x TF140662
- X = 125
- kg ~2,7



prägen
stamping
imprimer



powerCLAMP

X = 48
H = 34

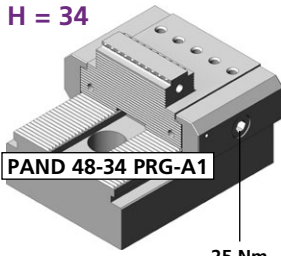

25 Nm

X = 94
H = 34

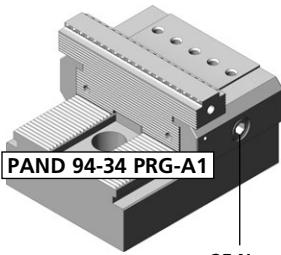

25 Nm

X = 48
H = 49

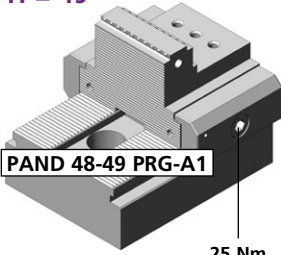

25 Nm

X = 94
H = 49

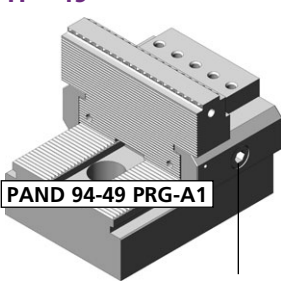

25 Nm

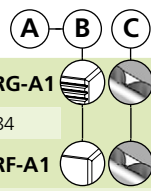
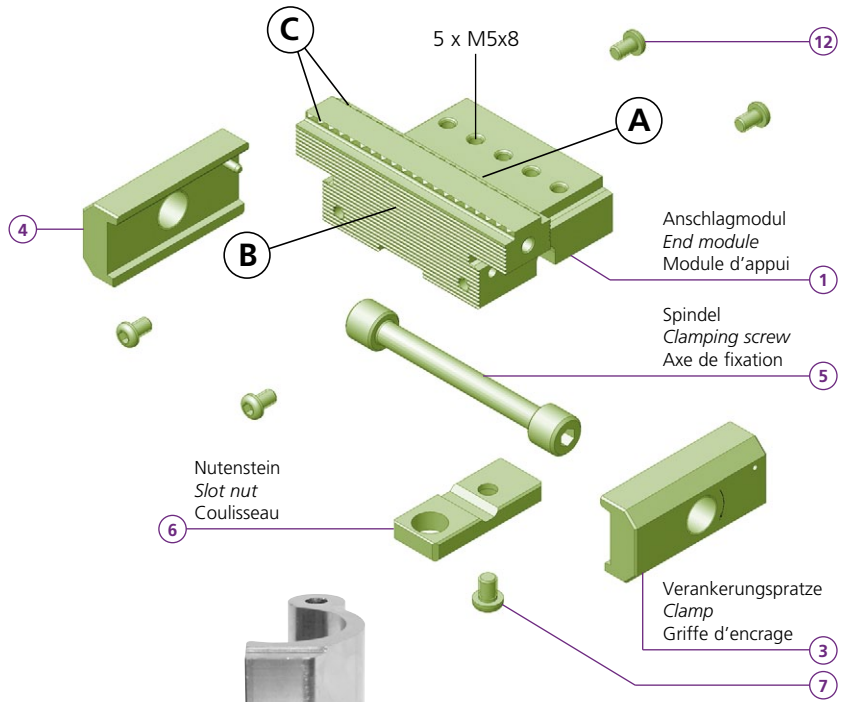
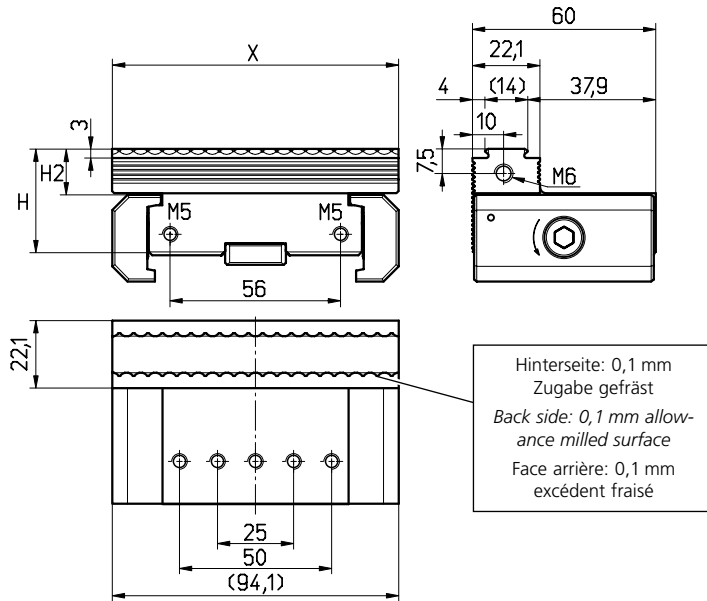

PAND 48-34 PRG-A1

1 1x TH120684

PAND 48-34 PRF-A1

1 1x TK140239

3 1x PCSP 60R

4 1x PCSP 60L

5 1x PCS 14

6 1x PCGU 20 49

7 1x M6x8 ISO 7380

12 4x M5x10 ISO 4762

X = 48

H = 34

H2 = 15

kg ~1,1

Bestellbeispiel / Ordering example / Exemple de commande: PAND 94-34 PRG-A1

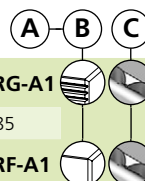

PAND 48-49 PRG-A1

1 1x TH120685

PAND 48-49 PRF-A1

1 1x TK140597

X = 48

H = 49

H2 = 30

kg ~1,1

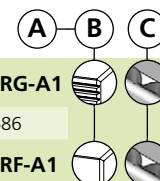

PAND 94-34 PRG-A1

1 1x TH120686

PAND 94-34 PRF-A1

1 1x TH140185

X = 94

H = 34

H2 = 15

kg ~1,1

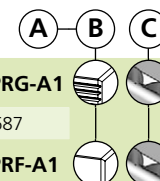

PAND 94-49 PRG-A1

1 1x TH120687

PAND 94-49 PRF-A1

1 1x TH130754

X = 94

H = 49

H2 = 30

kg ~1,1

PAND 94-34 PRGV PAND 94-49 PRGV



prägen
stamping
imprimer



powerCLAMP

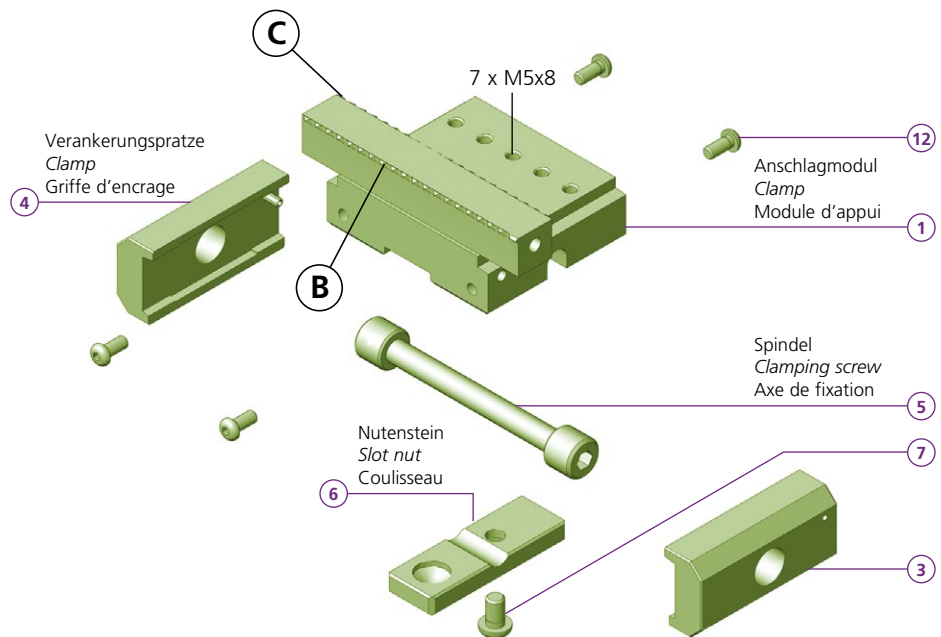
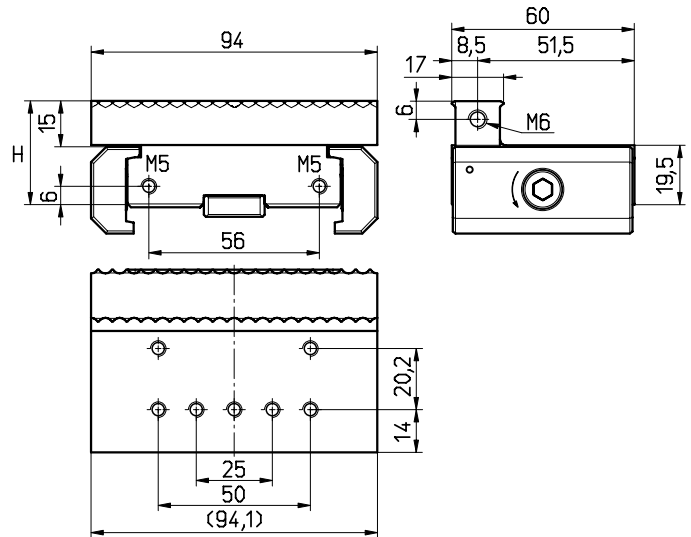
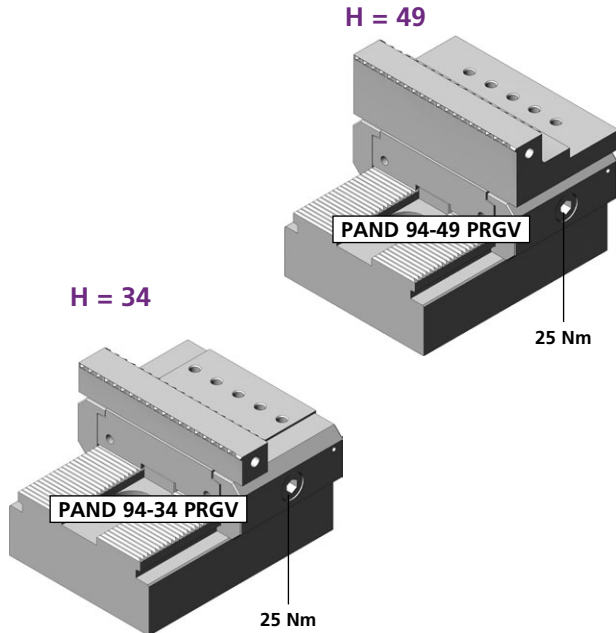

PAND 94-34 PRGV	
1	1x TK120690
3	1x PCSP 60R
4	1x PCSP 60L
5	1x PCS 14
6	1x PCGU 20 59
7	1x M6x8 ISO 7380
12	4x M5x10 ISO 4762
H	= 34
kg	~1,08

PAND 94-49 PRGV	
1	1x TK110249
H	= 49
kg	~1,6

Bestellbeispiel / Ordering example / Exemple de commande: **PAND 94-34 PRGV**

PAND 78-34 UPRG
PAND 78-49 UPRG
PAND 120-49 UPRG



prägen
stamping
imprimer



powerCLAMP

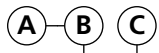
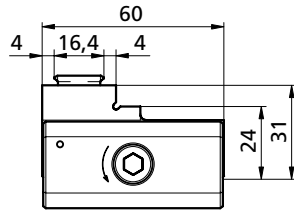
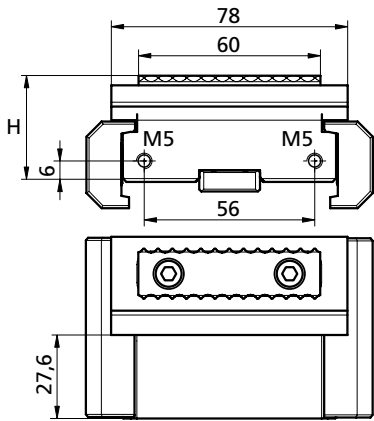

PAND 78-34 UPRG

- 1 1x TH140038
- 2 1x TK120226
- 3 1x PCSP 60R
- 4 1x PCSP 60L
- 5 1x PCS 14
- 6 1x PCGU 20 59
- 7 1x M6x8 ISO 7380
- 8 2x M5x16 DIN 912

kg ~1,1



PAND 78-49 UPRG

- 1 1x TH140039

kg ~1,5

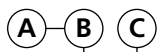
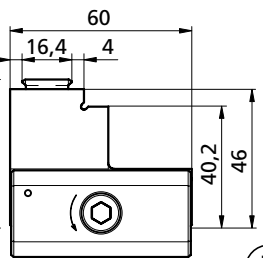
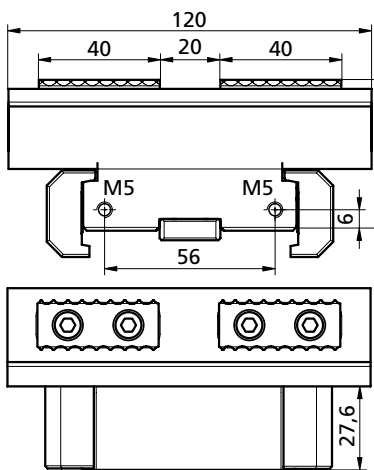
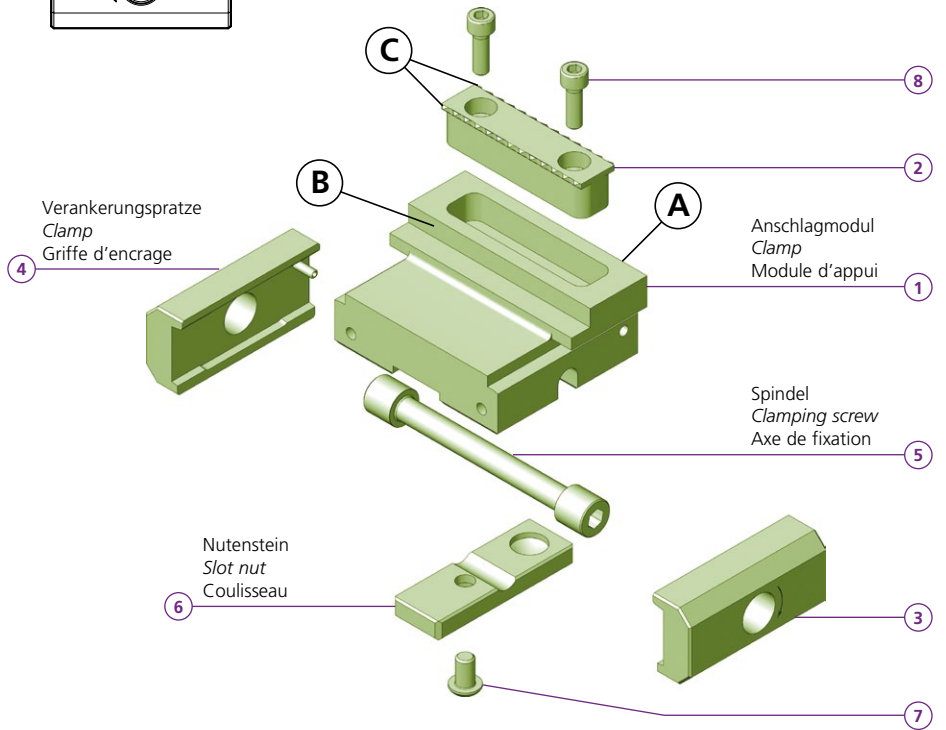

PAND 120-49 UPRG

- 1 1x TH160318
- 2 2x TK150234
- 3 1x PCSP 60R
- 4 1x PCSP 60L
- 5 1x PCS 14
- 6 1x PCGU 20 49
- 7 1x M6x8 ISO 7380
- 8 4x M5x16 DIN 912

kg ~1,5

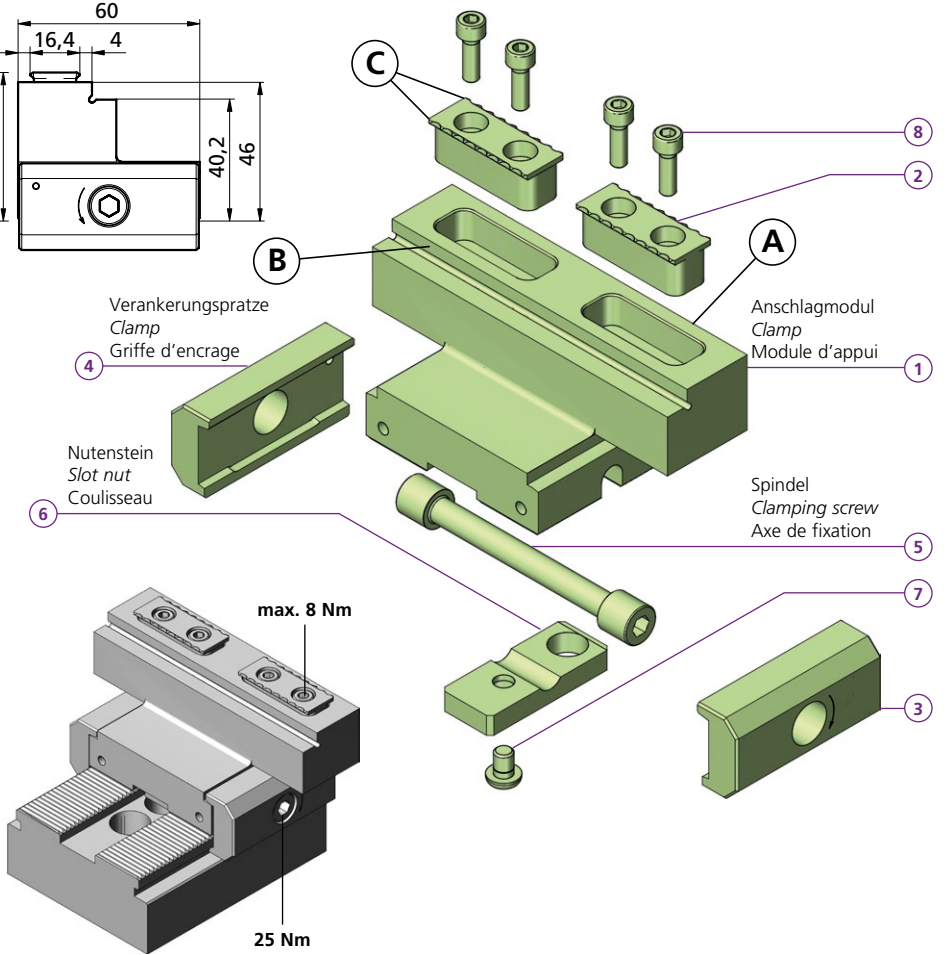

Bestellbeispiel / Ordering example / Exemple de commande: **PAND 120-49 UPRG**

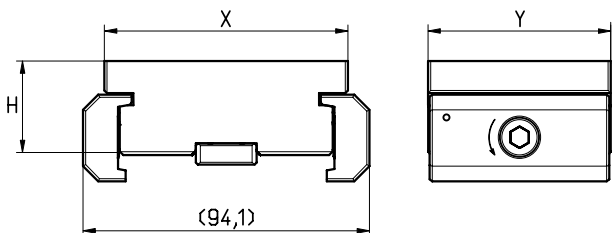

NS = Rohlingsmodul freie Positionierung ohne Verzahnung
 Carrier module without positioning serration for free positioning
 Support de module sans denture pour positionnement libre

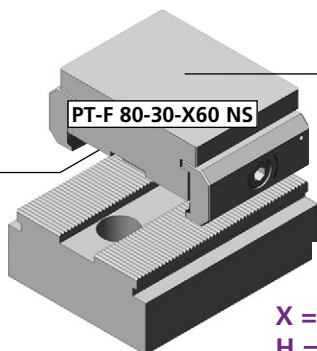
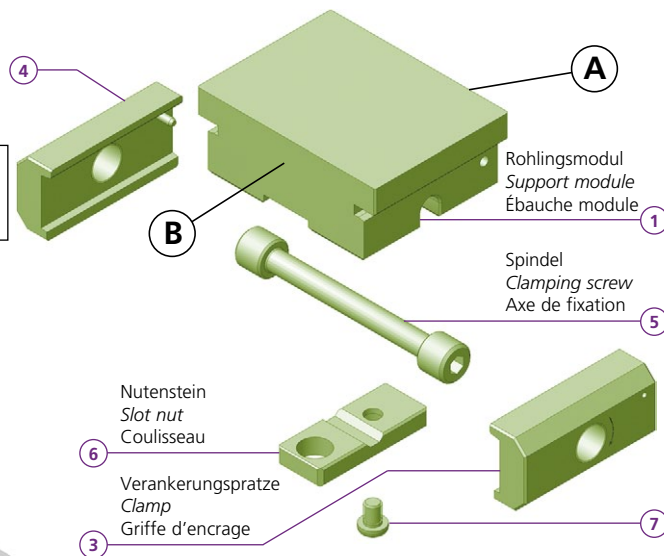

weich soft
doux 1.2312

X = 80
H = 30

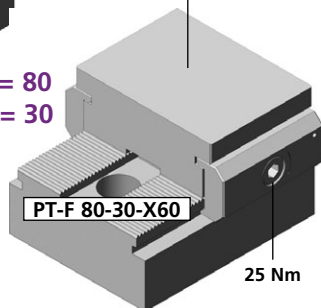

25 Nm

weich soft
doux 1.2312

X = 80
H = 30

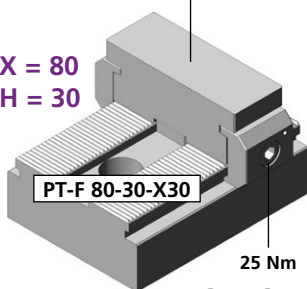

25 Nm

- PT-F 80-30 X30 NS**
- 1 1x TF140749
 - 3 1x PCSP 30R
 - 4 1x PCSP 30L
 - 5 1x PCS 14
 - 6 1x PCGU 20 30
 - 7 1x M6x8 ISO 7380
- X = 80
H = 30
Y = 30
kg ~0,5

- PT-F 61-25 X30**
- 1 1x TF140636
 - 3 1x PCSP 30R
 - 4 1x PCSP 30L
 - 6 1x PCGU 20 30
- X = 61
H = 25
Y = 30
kg ~0,6

X = 61
H = 25

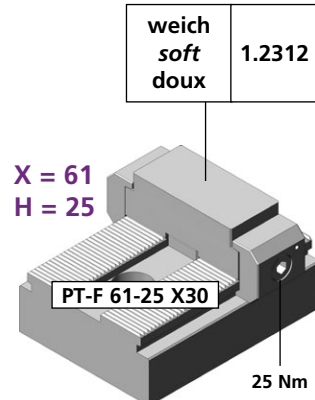

25 Nm

- PT-F 61-25 X50**
- 1 1x TF140750
 - 3 1x PCSP 50R
 - 4 1x PCSP 50L
 - 6 1x PCGU 20 49
- X = 61
H = 25
Y = 50
kg ~1,0

X = 61
H = 25

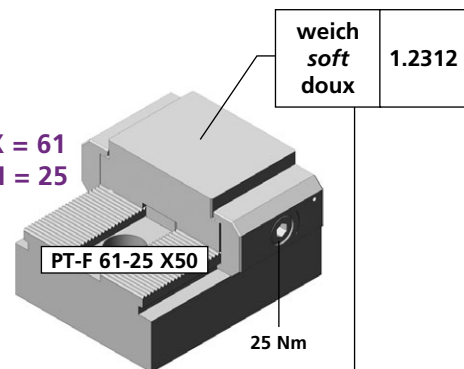

25 Nm

- PT-F 80-30 X60**
- 1 1x TF140637
- PT-F 80-30 X60 NS**
- 1 1x TF140635
 - 3 1x PCSP 60R
 - 4 1x PCSP 60L
 - 6 1x PCGU 20 49
- X = 80
H = 30
Y = 60
kg ~1,3

- PT-F 61-25 X60**
- 1 1x TF140638
 - 3 1x PCSP 60R
 - 4 1x PCSP 60L
- X = 61
H = 25
Y = 60
kg ~1,1

X = 61
H = 25

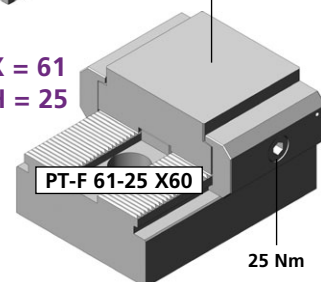

25 Nm

Bestellbeispiel
 Ordering example
 Exemple de commande: **PT-F 80-30 X60**

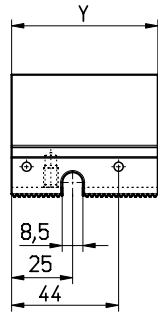
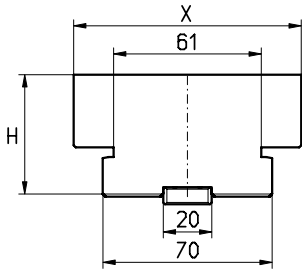

weich soft doux	1.2312
ALU	ENAW-7022

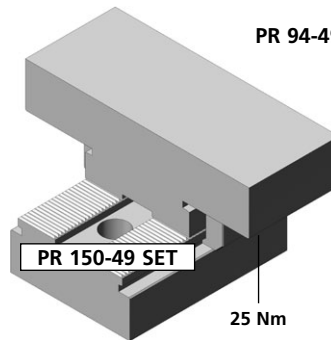
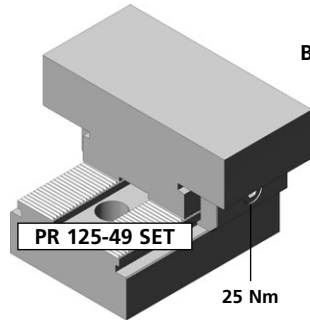
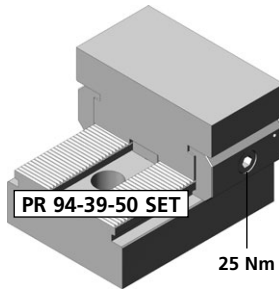
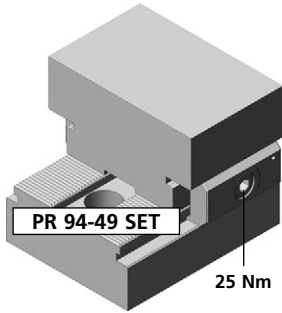
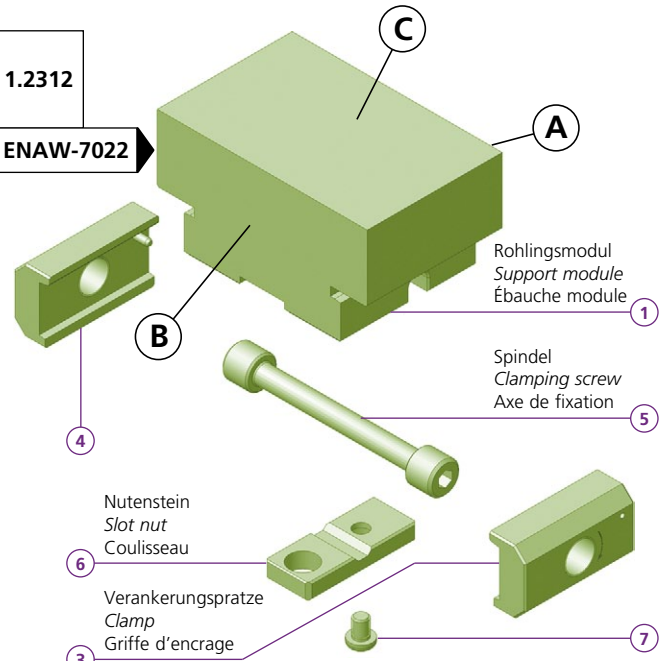

Bestellbeispiel / Ordering example / Exemple de commande: PR 94-49 SET

PR 94-49 SET = 1 Stück inkl. Zubehör
1 piece, including accessories
1 pièce accessoires

- PR 94-49 SET**
- 1 1x PR 94-49
 - 3 1x PCSP 50R
 - 4 1x PCSP 50L
 - 5 1x PCS 14
 - 6 1x PCGU 20 49
 - 7 1x M6x8 ISO 7380
- X = 94
H = 49
Y = 60,4
kg ~2,2

- PR 94-39-50 SET**
- X = 94
H = 39
Y = 50,4
kg ~1,5

- PR 125-49 SET**
- X = 125
H = 49
Y = 60,4
kg ~2,7

- PR 125-49 SETALU**
- X = 125
H = 49
Y = 60,4
kg ~0,83

- PR 150-49 SET**
- X = 150
H = 49
Y = 60,4
kg ~3,0

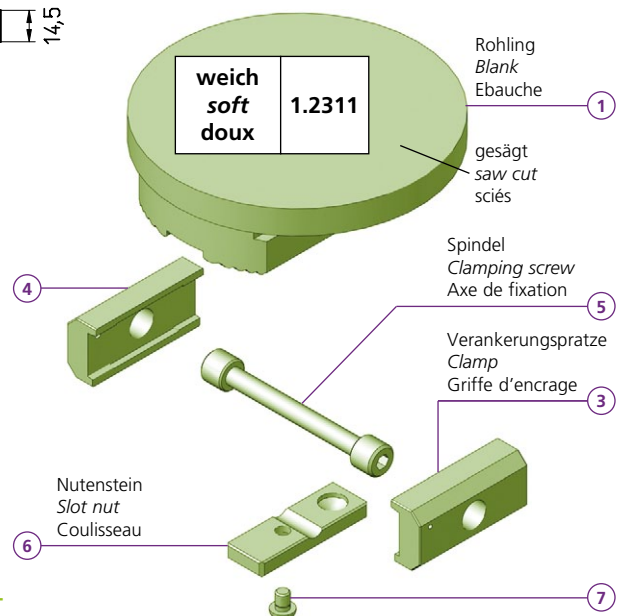
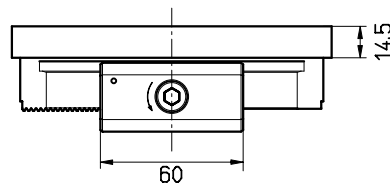
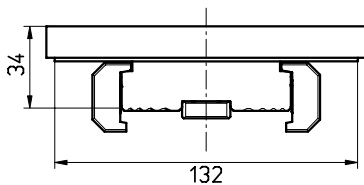

- PT-F 132-34 RD SET**
- 1 1x PT-F 132-34 RD
 - 3 1x PCSP 60R
 - 4 1x PCSP 60L
 - 5 1x PCS 14
 - 6 1x PCGU 20 59
 - 7 1x M6x8 ISO 7380
- kg ~3,1

Bestellbeispiel
Ordering example
Exemple de commande: PT-F 132-34 RD SET

Rohlingsmodule

Blank module PTX 160 -77 S

Ébauche module PTX 160 -57 S



powerCLAMP

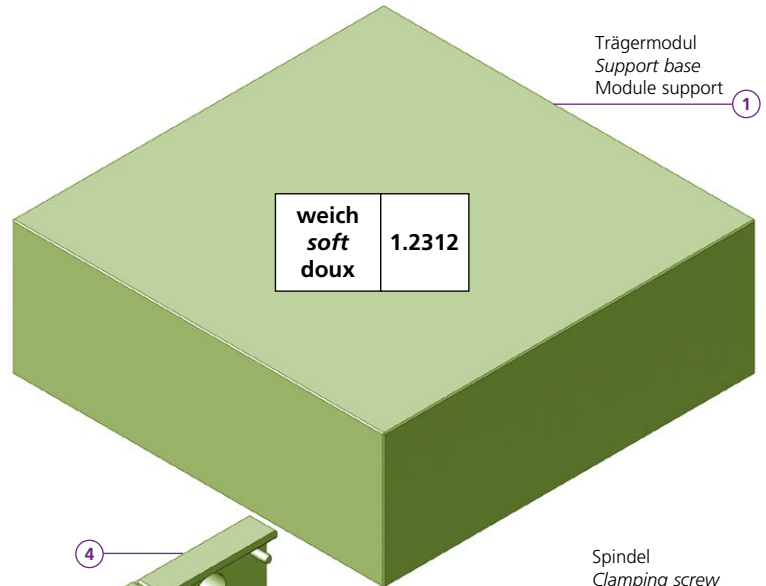
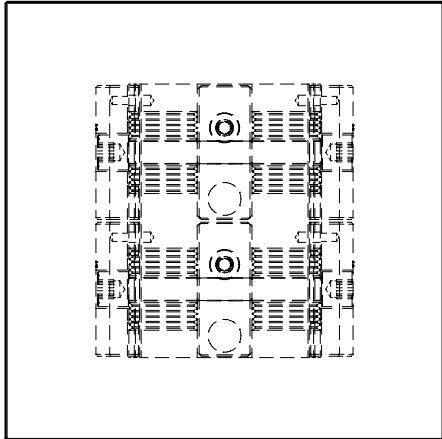
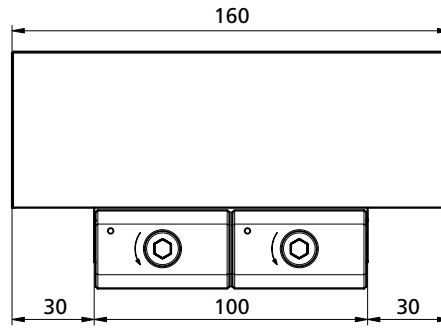
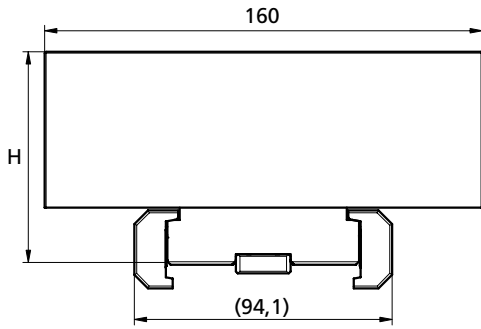

Trägermodul
Support base
Module support

1

weich
soft
doux 1.2312

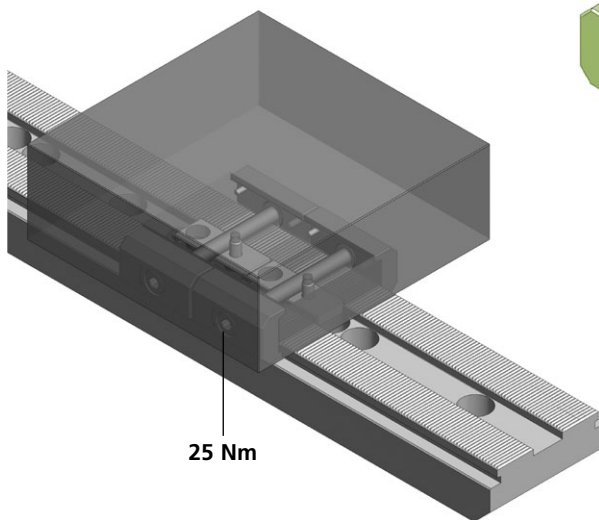

25 Nm

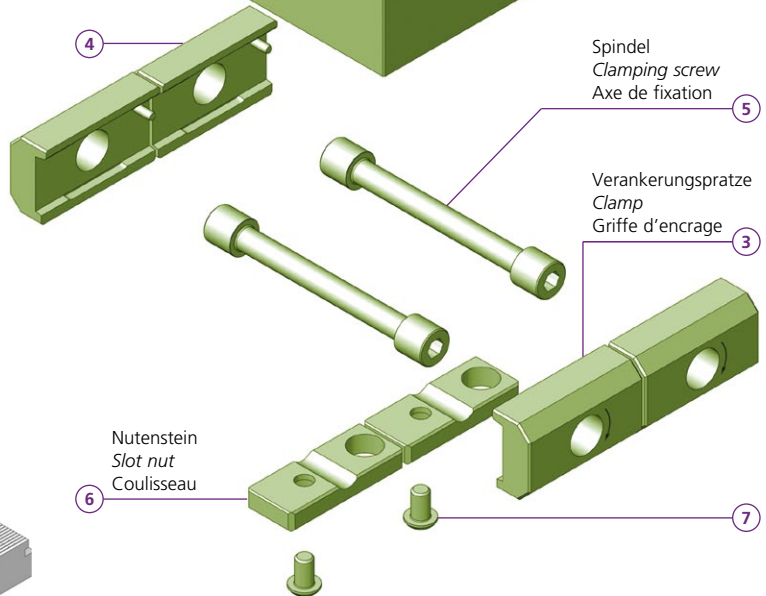

Spindel
Clamping screw
Axe de fixation

5

Verankerungspratze
Clamp
Griffe d'encrage

3

Nutenstein
Slot nut
Coulisseau

6

7

PTX 160 -77 S

1 1x TH130723

H = 77

kg ~13

PTX 160 -57 S

1 1x TH130539

3 2x PCSP 50R

4 2x PCSP 50L

5 2x PCS 14

6 2x PCGU 20 59

7 2x M6x8 ISO 7380

H = 57

kg ~9

Bestellbeispiel / Ordering example / Exemple de commande: PTX 160 -57 S

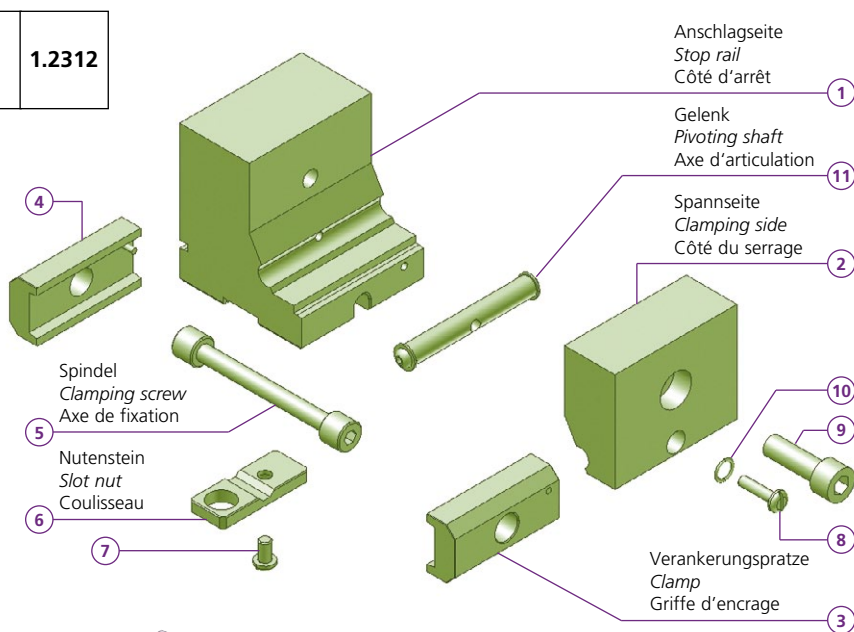
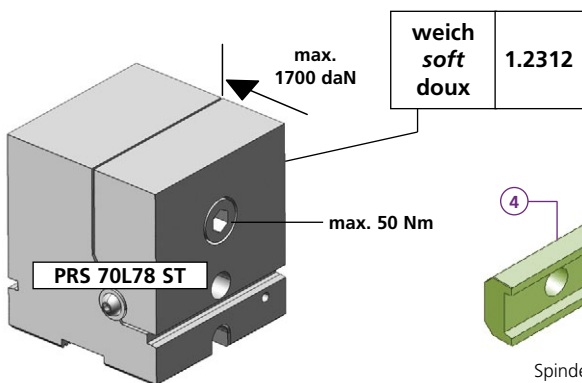
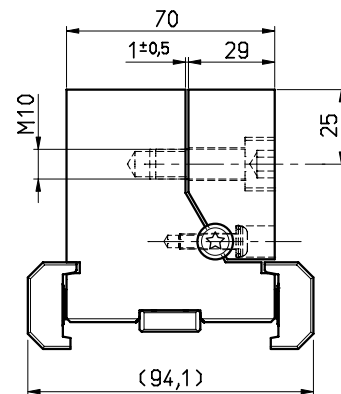
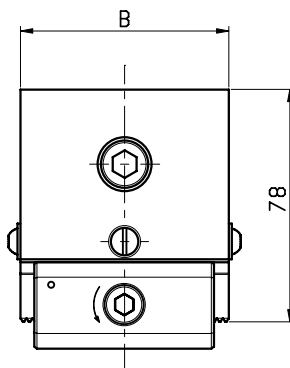
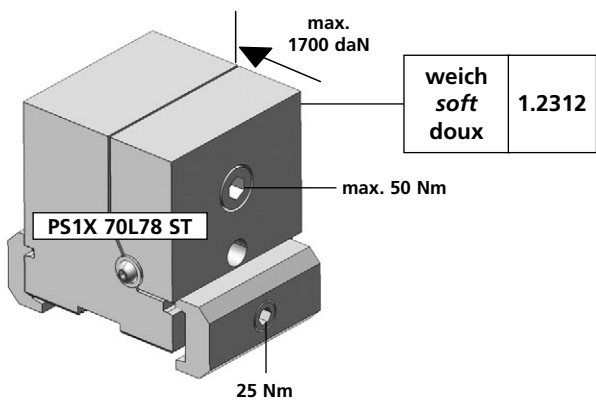

Drehmoment Torque Couple de torsion	Spannkraft Workholding force Force de serrage
10 Nm lb-ft 7,4	= 0,34 t 340 daN
20 Nm lb-ft 14,8	= 0,68 t 680 daN
30 Nm lb-ft 22,1	= 1,02 t 1020 daN
40 Nm lb-ft 29,5	= 1,36 t 1360 daN
50 Nm lb-ft 36,8	= 1,7 t 1700 daN

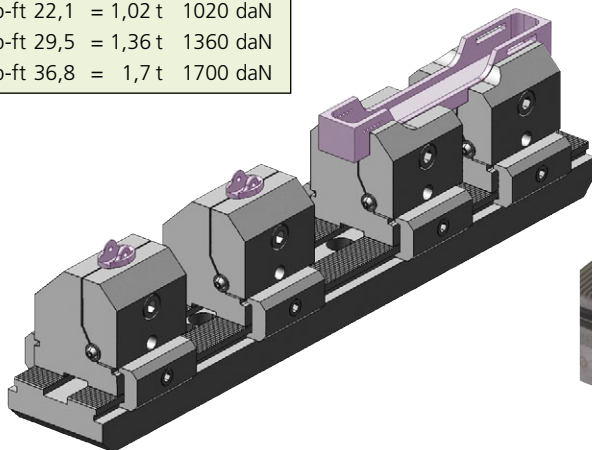

Spannbacken Rohling auf Kundenwunsch angepasst
Jaw blank machined to customer specification
Ebauches mors de serrage adaptés sur demande du client

Bestellbeispiel / Ordering example / Exemple de commande: **PS1X 70L78 ST**

PS1X 70L78 ST	
1	1x PRS7078AST
2	1x PRS7078SST
3	1x PCSP 60R
4	1x PCSP 60L
5	1x PCS 14
6	1x PCGU 20 49
7	1x M6x8 ISO 7380
8	1x M5x20 BN 1362
9	1x M10x30 ISO 4762
10	1x OR Ø 8x1,5
11	1x PRS 7078 G
B	= 70
kg	~3,1

PS1X 50L78 ST	
1	1x PRS5078AST
2	1x PRS5078SST
3	1x PCSP 50R
4	1x PCSP 50L
11	1x PRS 5078 G
B	= 50
kg	~2,3

PRS 70L78 ST	
1	1x PRS7078AST
2	1x PRS7078SST
11	1x PRS 7078 G
B	= 70
kg	~2,8

PRS 50L78 ST	
1	1x PRS5078AST
2	1x PRS5078SST
11	1x PRS 5078 G
B	= 50
kg	~2,0

Dreibackenfutter
Three jaw chuck
Mandrin à trois mors

PS3X 80L75 BSET
PS3X 100L82 BSET
PS3X 125L87 BSET



powerCLAMP

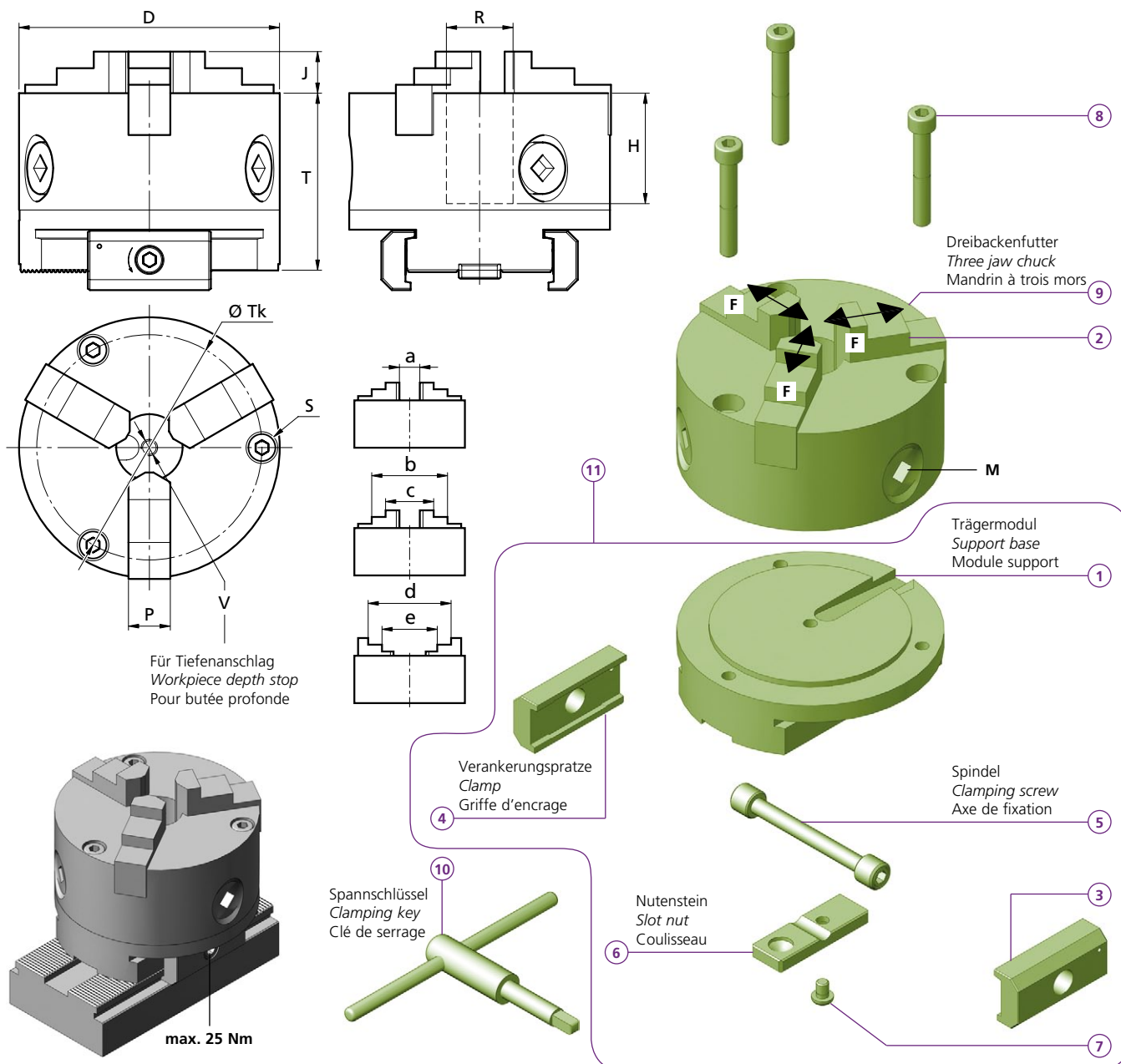

Bestellbeispiel / Ordering example / Exemple de commande: **PS3X 125L87 BSET**

	D	J	T	R	H	P	V	a mm	b mm	c mm	d mm	e mm	max. M	max. F	ØTk	S
PS3X 80L75 BSET	80	13	75	15	42,5	10	M6	3...27	48...73	23...48	52...76	27...51	28 Nm	1300 daN	67	M6
PS3X 100L82 BSET	100	17	82	20	49,5	14	M8	3...39	58...94	24...60	64...100	30...66	38 Nm	1600 daN	83	M8
PS3X 125L87 BSET	125	19	87	32	55	16	M8	3...49	70...116	30...75	83...125	38...84	55 Nm	2600 daN	108	M8

PS3X 80L75 BSET

- 1 1x PTX 80-30
- 2 2x 3 Stk. / pcs
- 3 1x PCSP 60R
- 4 1x PCSP 60L
- 5 1x PCS 14
- 6 1x PCGU 20 59
- 7 1x M6x8 ISO 7380
- 8 3x M6x45 ISO 4762
- 9 1x 243809.0083220
- 10 1x 243864.0080000
- kg ~2,8
- 11 **PTX80-30**

PS3X 100L82 BSET

- 1 1x PTX 100-30
- 2 2x 3 Stk. / pcs
- 8 3x M8x50 ISO 4762
- 9 1x 243809.0103220
- 10 1x 243864.0100000
- kg ~4,2
- 11 **PTX100-30**

PS3X 125L87 BSET

- 1 1x PTX 125-29
- 2 2x 3 Stk. / pcs
- 8 3x M8x55 ISO 4762
- 9 1x 243809.0123220
- 10 1x 243864.0120000
- kg ~6,4
- 11 **PTX125-29**

Ordering information for different diameters (Ø):

- 80-100: 243849.0083200, 243850.0083200, *243834.0083300
- 100-125: 243849.0103200, 243850.0103200, *243834.0103300
- 125-: 243849.0123200, 243850.0123200, *243834.0123300

Additional components: Weich Soft 16MnCr5 Doux (3x), Ø 3 - 49, Ø 38 - 125.

Separat bestellen / Separate order / Commander séparément

PS1X 50N100 -ER32 Ø 1 - 22 mm

PS1X 50N62 -ER32 Ø 1 - 22 mm

PS1X 63N100 -ER40 Ø 2 - 30 mm



powerCLAMP

ER32 1-22 mm / 2-30 mm ER40

ER32 50 / 63 ER40

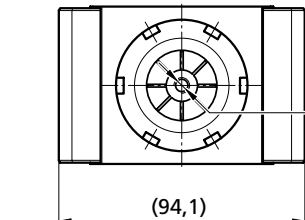
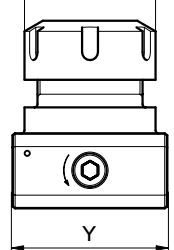
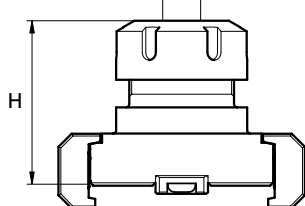

M6 Für Tiefenanschlag
For depth stop
Pour une butée profonde

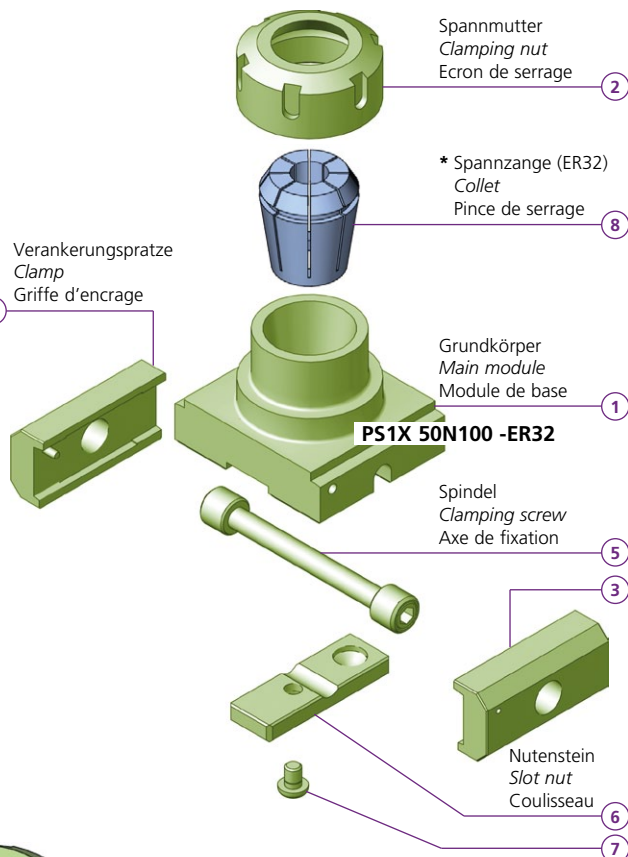
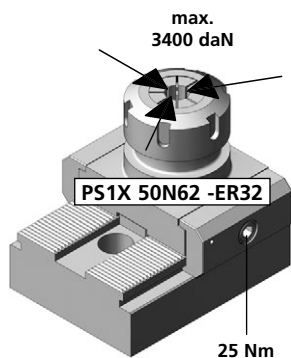
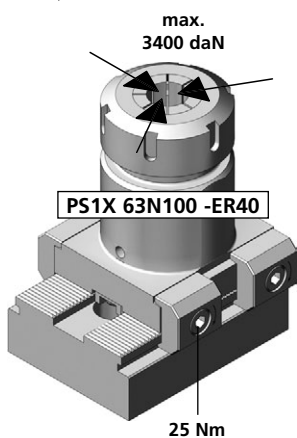

PS1X 50N62 -ER32

①	1x TW090089-01
②	1x ER32
③	1x PCSP 60R
④	1x PCSP 60L
⑤	1x PCS 14
⑥	1x PCGU 20 59
⑦	1x M6x8 ISO 7380
⑧	1x * ER32
H	= 62
Y	= 60
kg	~1,5

PS1X 50N100 -ER32

①	1x TW090047-01
H	= 100
Y	= 60
kg	~2,2

PS1X 63N100 -ER40

①	1x TW110026-01
②	1x ER40
③	2x PCSP 30R
④	2x PCSP 30L
⑤	2x PCS 14
⑥	2x PCUG 20 20
⑦	2x M6x8 ISO 7380
⑧	1x * ER40
⑨	1x BN42 - DIN 908 - M33x2
H	= 100
Y	= 80
kg	~2,6

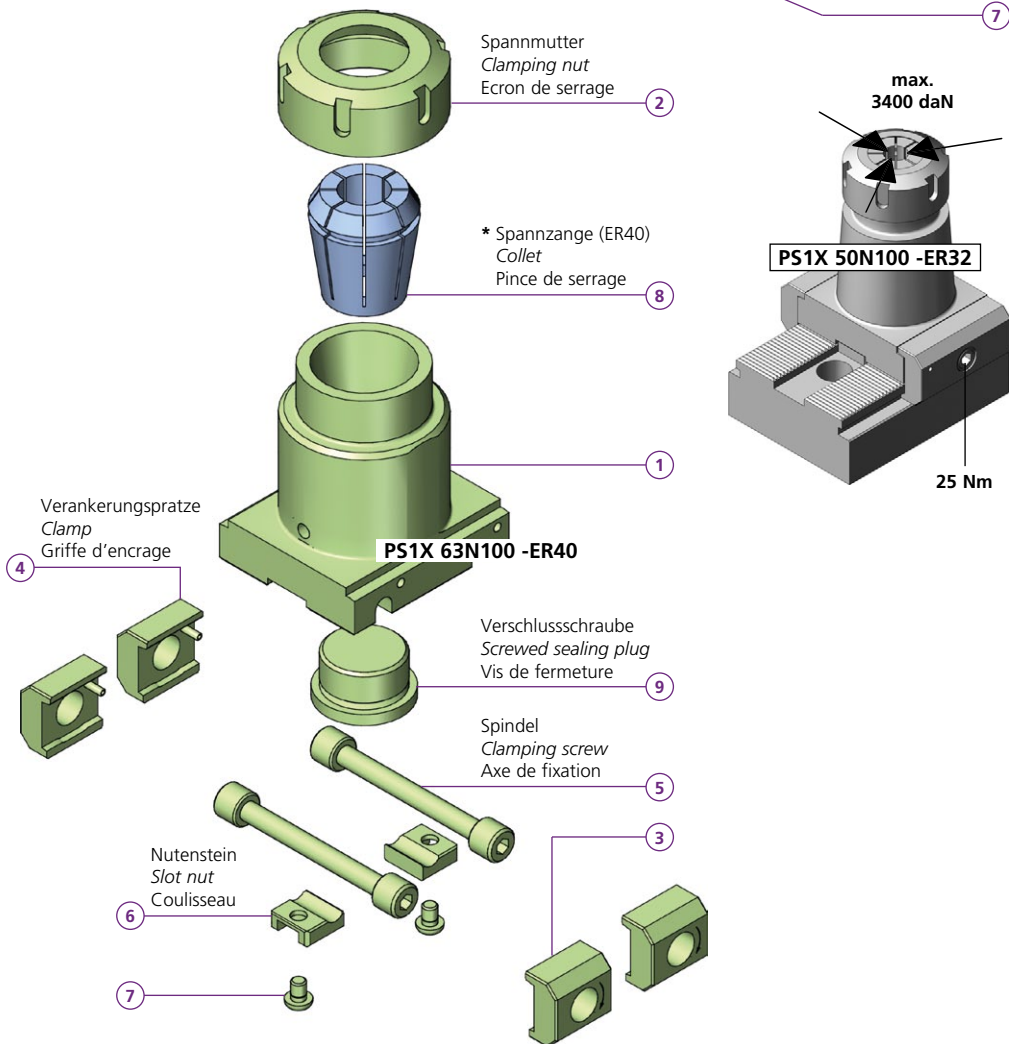

Bestellbeispiel / Ordering example / Exemple de commande:
1x PS1X 50N62 -ER32 & 1x ER32

Separat bestellen / Separate order / Commander séparément

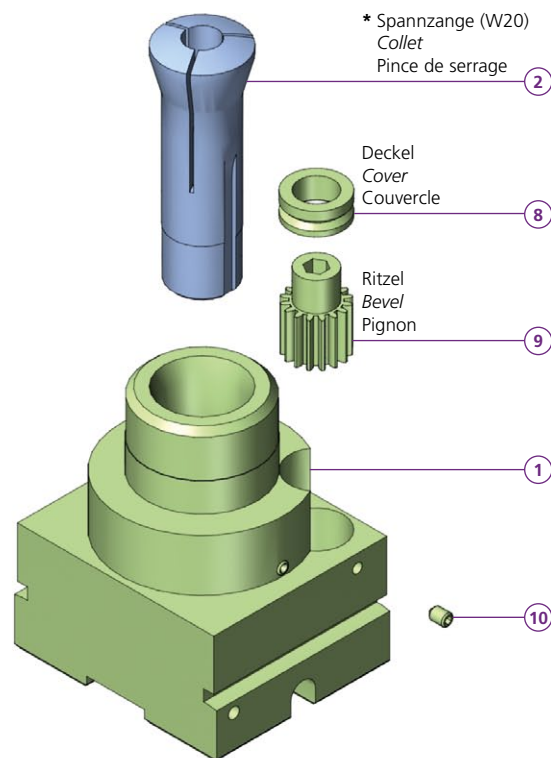
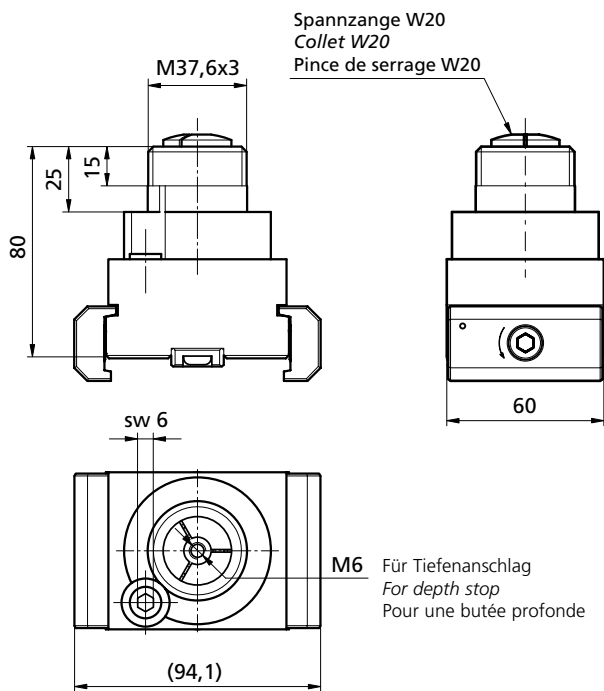

weich / soft / doux

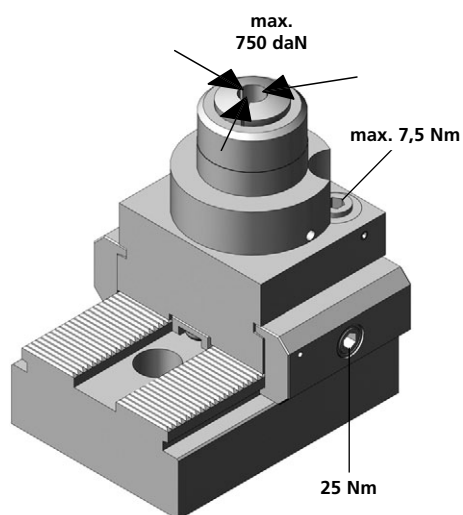
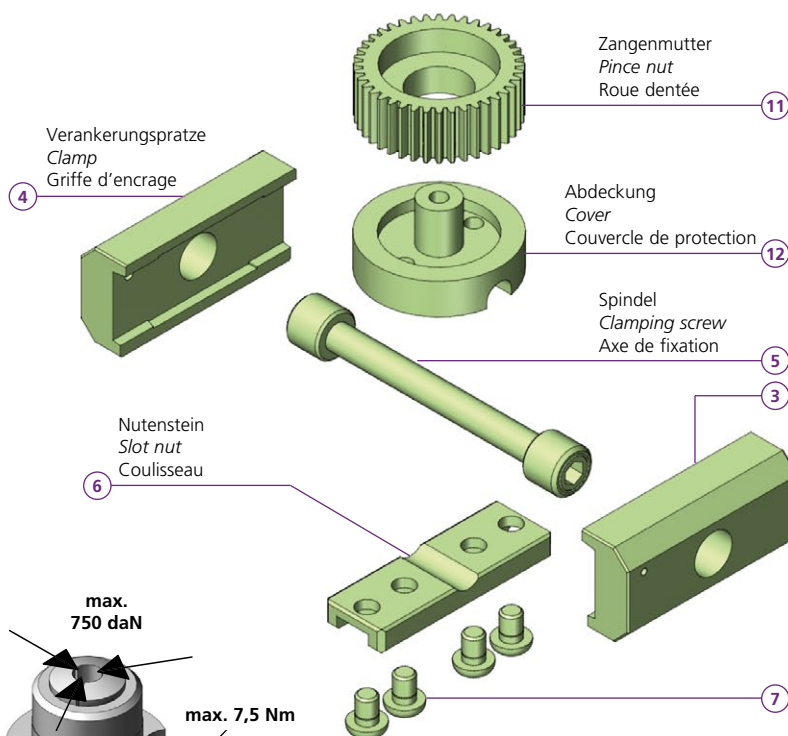
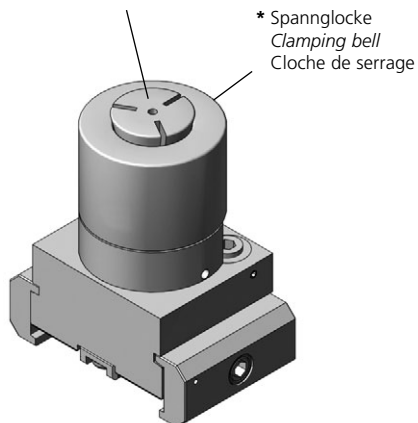

PS1X 68N80 -W20

①	1x TW080018-01
②	1x * W20
③	1x PCSP 60R
④	1x PCSP 60L
⑤	1x PCS 14
⑥	1x PCGU W20
⑦	4x M6x8 ISO 7380
⑧	1x PCD 1808
⑨	1x PCRZ 1825
⑩	1x M4x6 ISO 4027
⑪	1x PCZM 4215
⑫	1x PCABD 4221

kg ~1,76

Bestellbeispiel / Ordering example / Exemple de commande:
1x PS1X 68N80 -W20 & 1x W20



PS1F -KLD1
PS1F -KLD1 NS

powerCLAMP

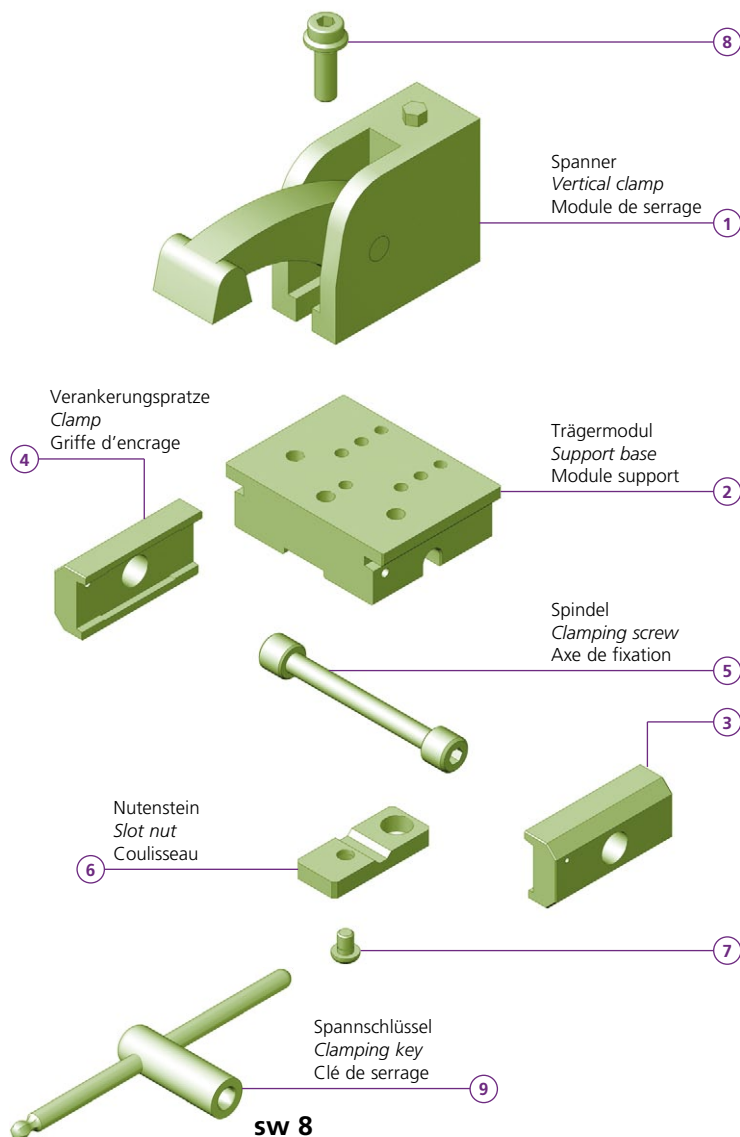
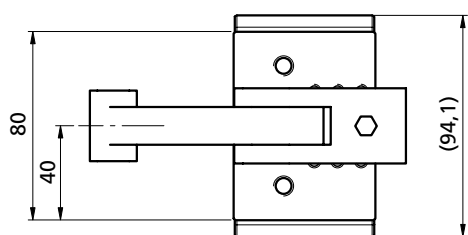
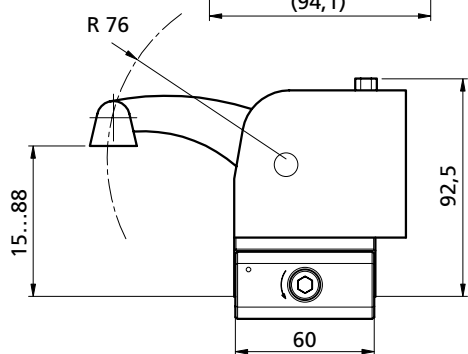
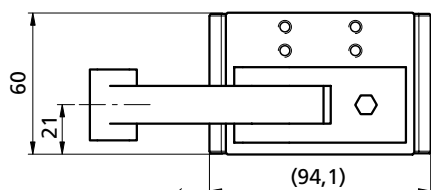
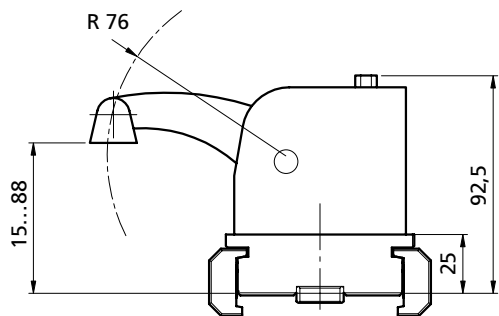

Bestellbeispiel / Ordering example / Exemple de commande: PS1F -KLD1 NS

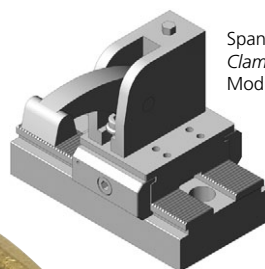

Spanner quer montiert
Clamp mounted transversely
Module de serrage vertical monté transversalement

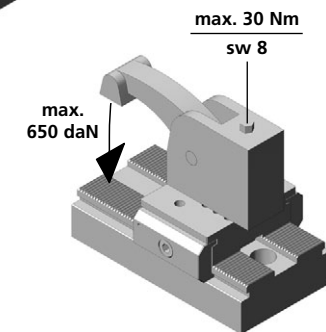

Spanner längs montiert
Clamp mounted longitudinally
Module de serrage vertical monté longitudinalement

PS1F -KLD1	
1	1x 07-020
2	1x PCTMV1F
3	1x PCSP 60R
4	1x PCSP 60L
5	1x PCS 14
6	1x PCGU 20 49
7	1x M6x8 ISO 7380
8	1x M8x25 TW080012-02
9	1x 07-180
kg	~2,2

PS1F -KLD1 NS	
2	1x PCTMV1FNS
kg	~2,2



NS = Trägermodul freie Positionierung ohne Verzahnung
Carrier module without positioning serration for free positioning
Support de module sans denture pour positionnement libre

Plattenspanner

Plate clamping modul

PS1F 20L35 BV1

Serrage pour plaques

PS1F 20L35 BV1 NS



powerCLAMP

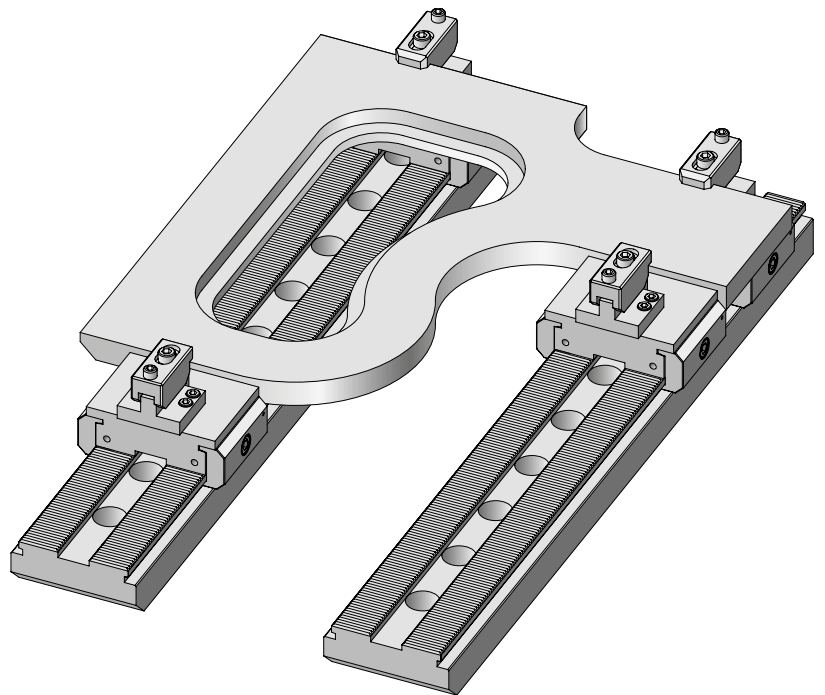
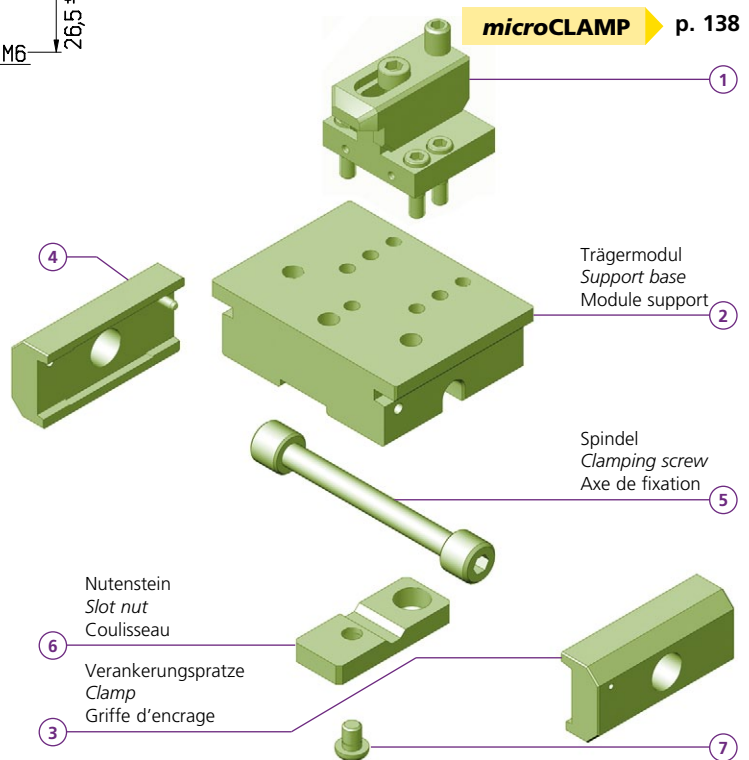
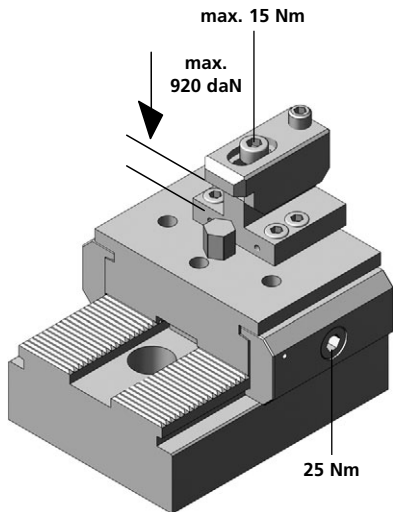
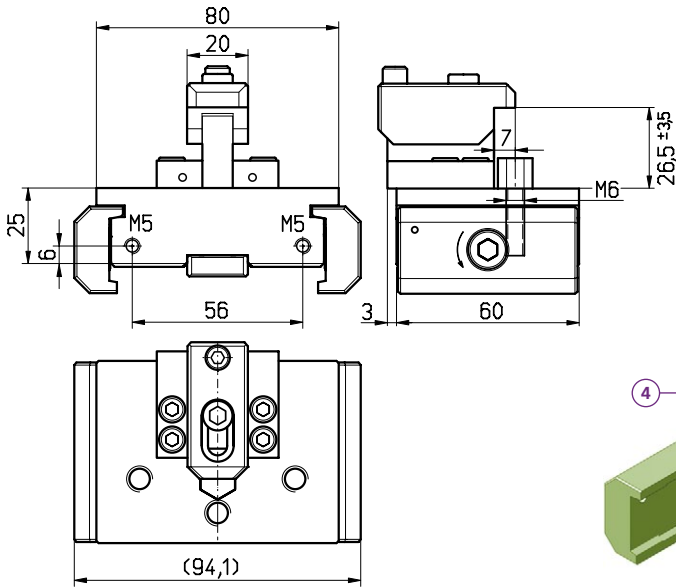

PS1F 20L35 BV1

- 1x MV1F 20L35 BV1
- 1x PCTMV1F
- 1x PCSP 60R
- 1x PCSP 60L
- 1x PCS 14
- 1x PCGU 20 49
- 1x M6x8 ISO 7380

kg ~1,3

PS1F 20L35 BV1 NS

- 1x PCTMV1FNS

kg ~1,3

NS = Trägermodul freie Positionierung ohne Verzahnung
Carrier module without positioning serration for free positioning
Support de module sans denture pour positionnement libre

Bestellbeispiel / Ordering example / Exemple de commande: **PS1F 20L35 BV1**

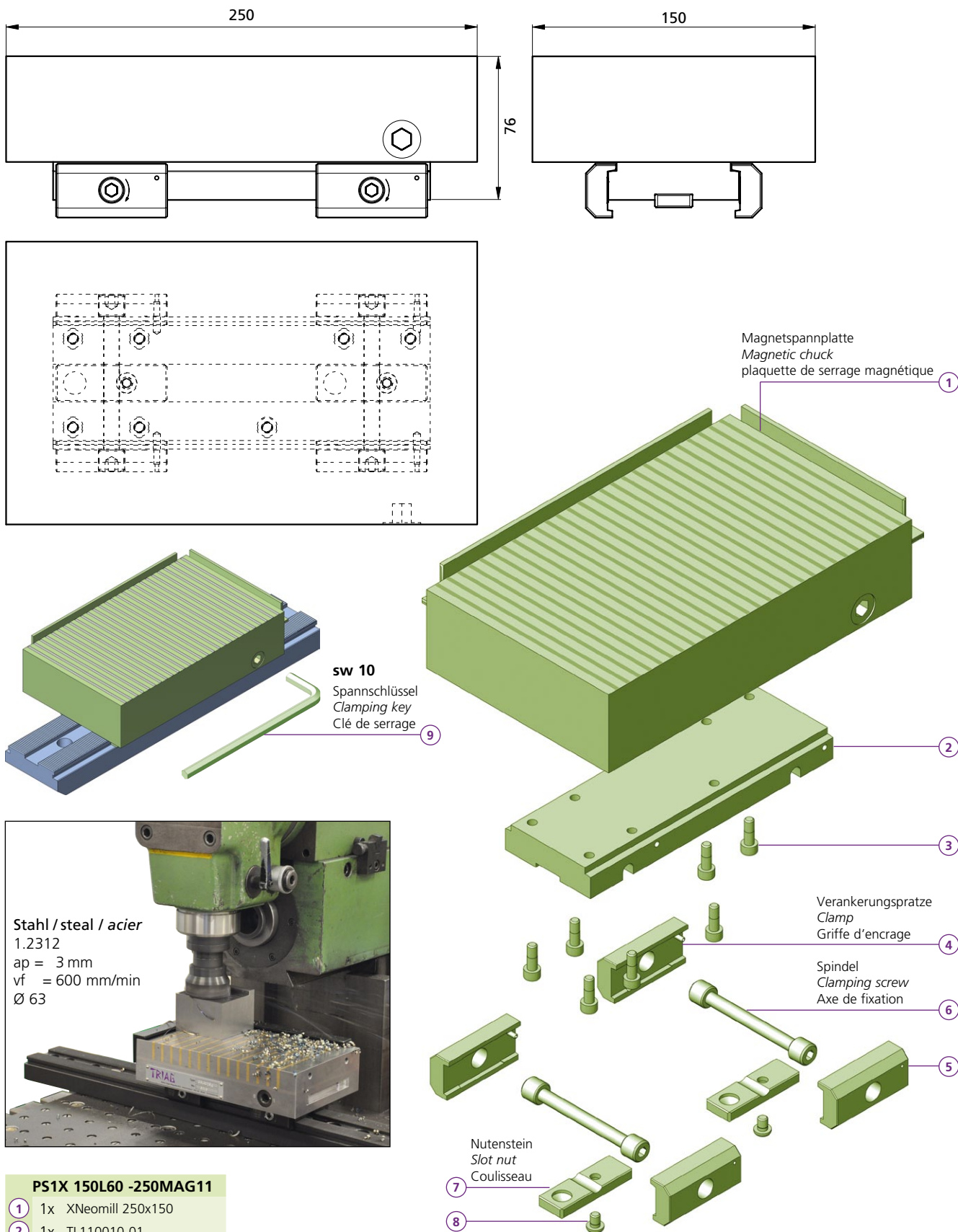

PS1X 150L60 -250MAG11

- ① 1x XNeomill 250x150
- ② 1x TL110010-01
- ③ 7x MS60
- ④ 2x PCSP 60L
- ⑤ 2x PCSP 60R
- ⑥ 2x PCS 14
- ⑦ 2x PCGU 2049
- ⑧ 2x ISO 7380 M6x8
- ⑨ 1x ISL10 DIN 911L

kg ~21

max. Haltekraft / max. holding force / force de tenue maximale = 120 N/cm²

- Werkstücke ab 26 mm Länge und 6 mm Stärke werden optimal gespannt
- Workpieces from 26 mm length and 6mm thickness will be optimally hold
- Pièces à usiner de 26 mm de longueur et 6 mm d'épaisseur sont serrées optimales

Bestellbeispiel / Ordering example / Exemple de commande: **PS1X 150L60 -250MAG11**

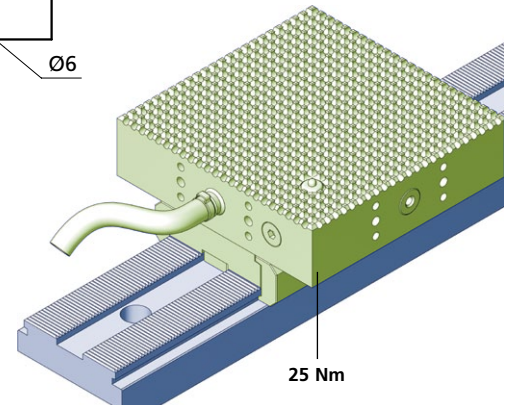
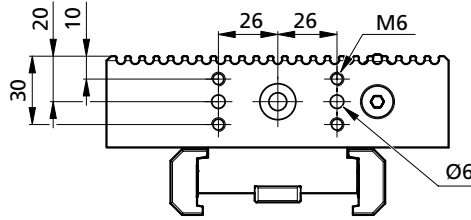
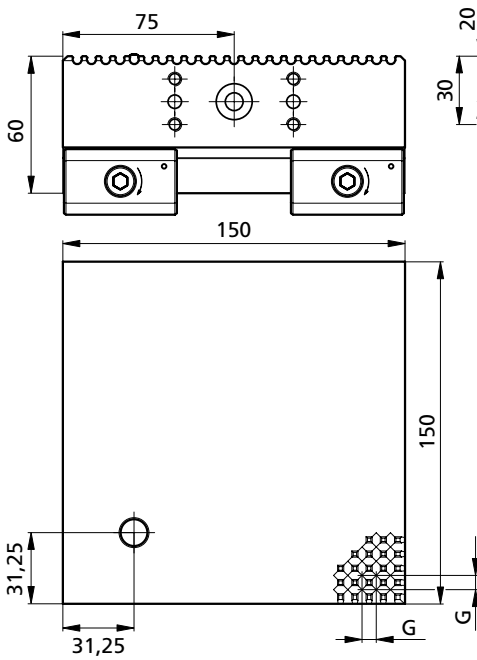

Mehr Informationen siehe Vacuum (Triva Clamp Seite 181)
For more information check the vacuum workholding (Triva Clamp Page 181)
Pour plus d'informations visiter le vacuum (Page 181 Triva Clamp)

Bestellbeispiel / Ordering example / Exemple de commande: **PS1X 150L60-VAC**

Zentrischspanner / Self centring vise / Module à centrer p. 249 - 274

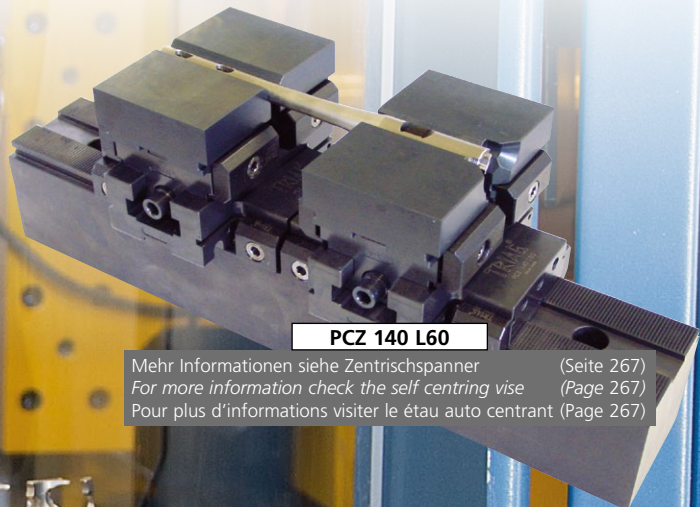
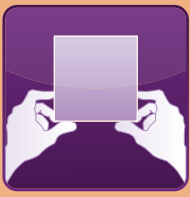

PCZ 140 L60

Mehr Informationen siehe Zentrischspanner (Seite 267)
For more information check the self centring vise (Page 267)
Pour plus d'informations visiter le étau auto centrant (Page 267)

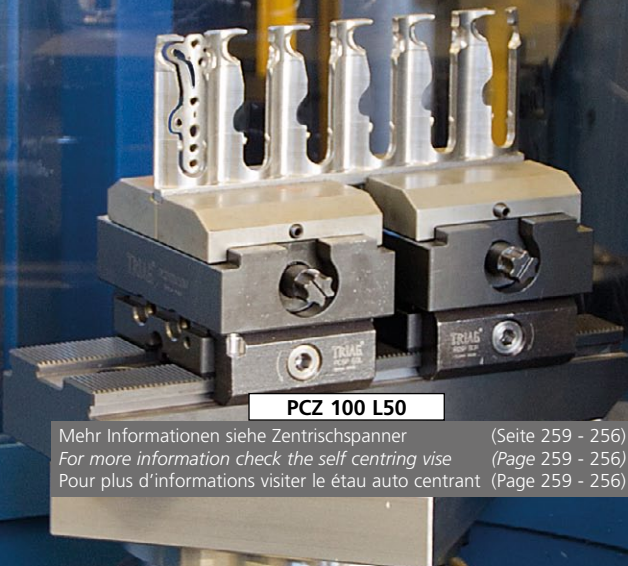

PCZ 100 L50

Mehr Informationen siehe Zentrischspanner (Seite 259 - 256)
For more information check the self centring vise (Page 259 - 256)
Pour plus d'informations visiter le étau auto centrant (Page 259 - 256)

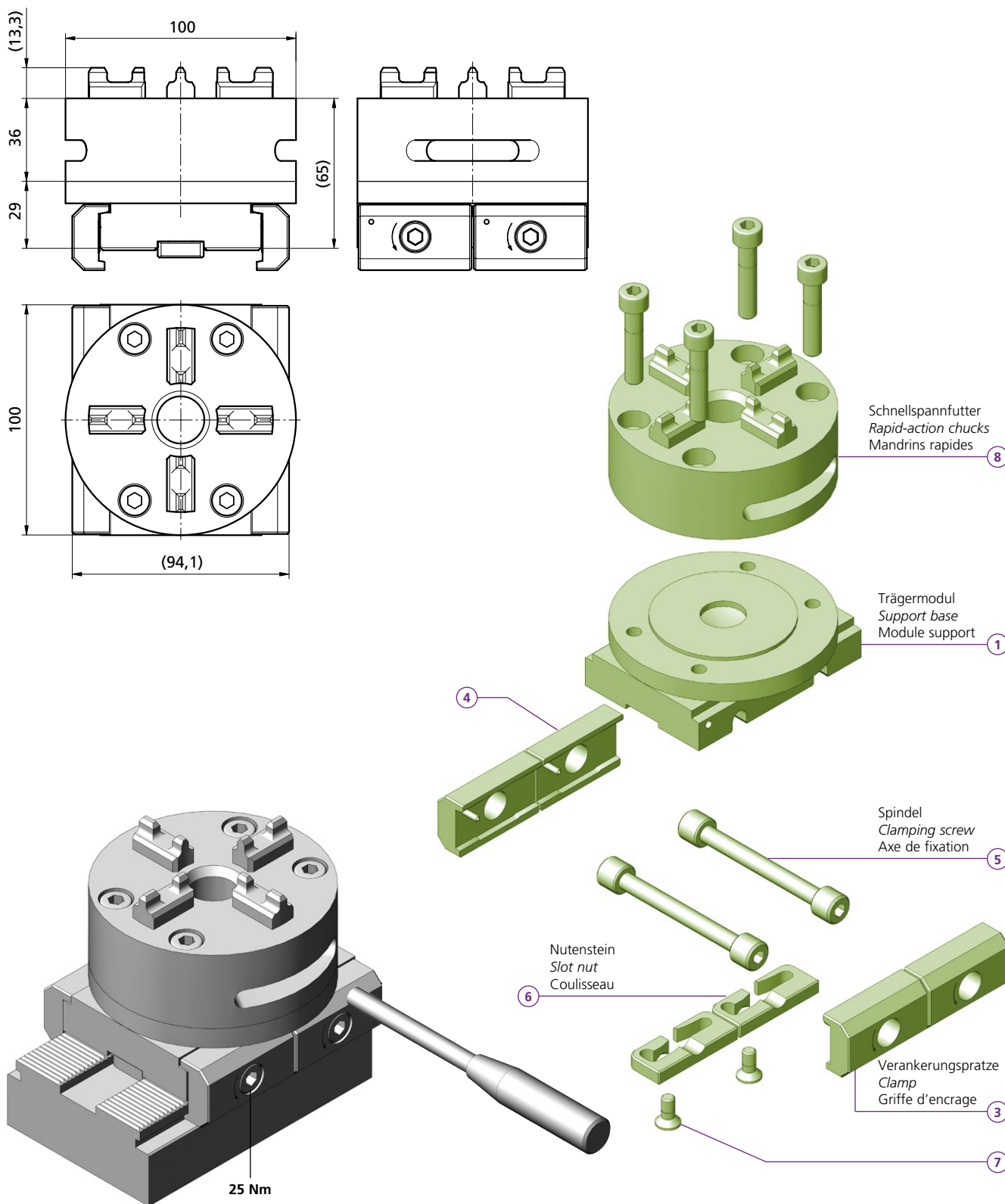

PS1X 100-65 ER-036345

- 1x PTX100-29
- 2x PCSP 50L
- 2x PCSP 50R
- 2x PCS 14
- 2x PCGU 20 49F
- 2x M6x14 ISO 10642 BN20
- 1x ER-036345

kg ~4,0

Bestellbeispiel / Ordering example / Exemple de commande: PS-X 100-65 EROWA

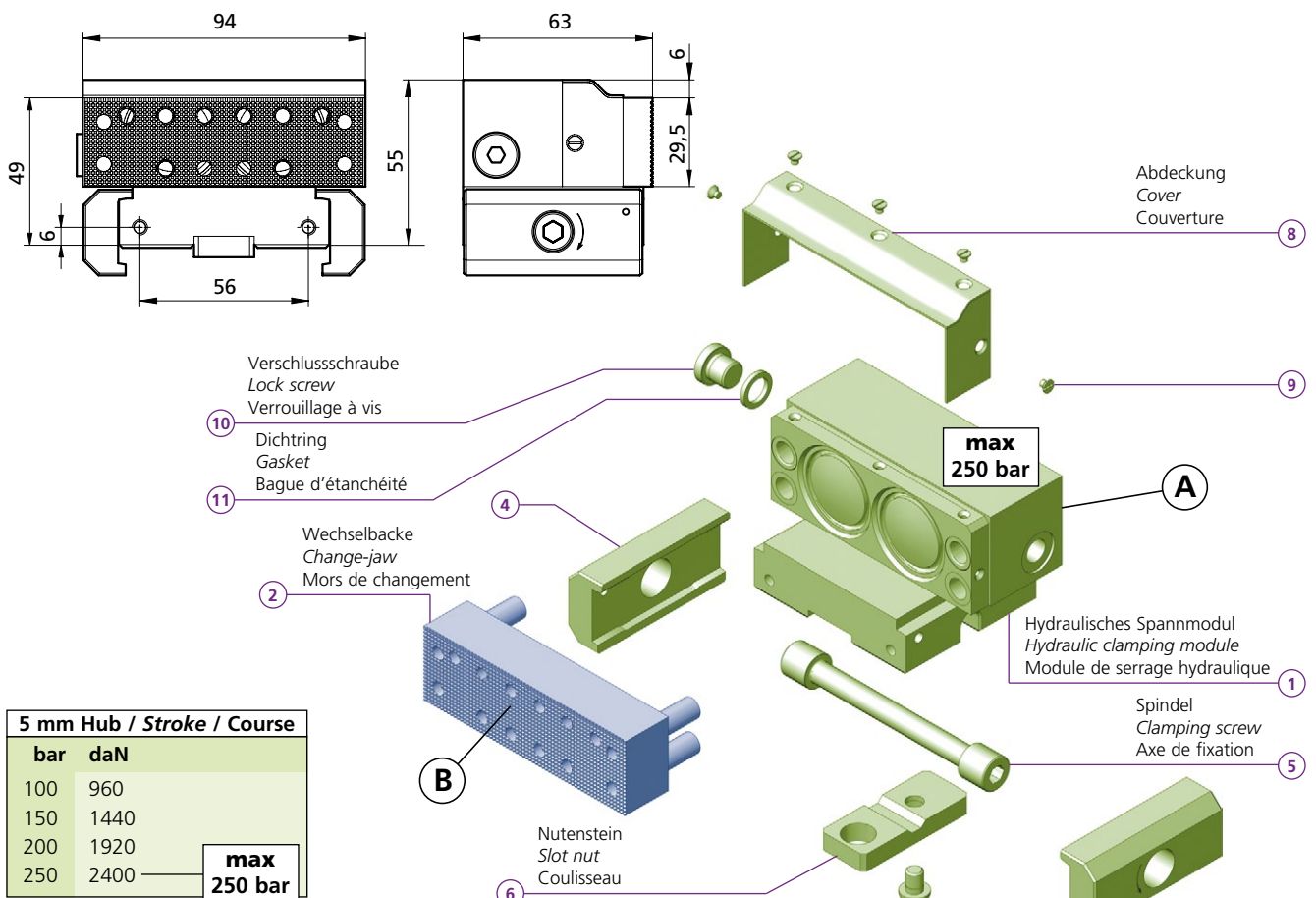
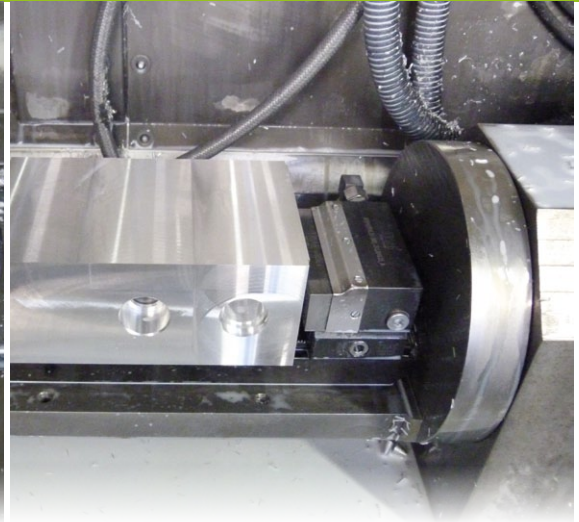
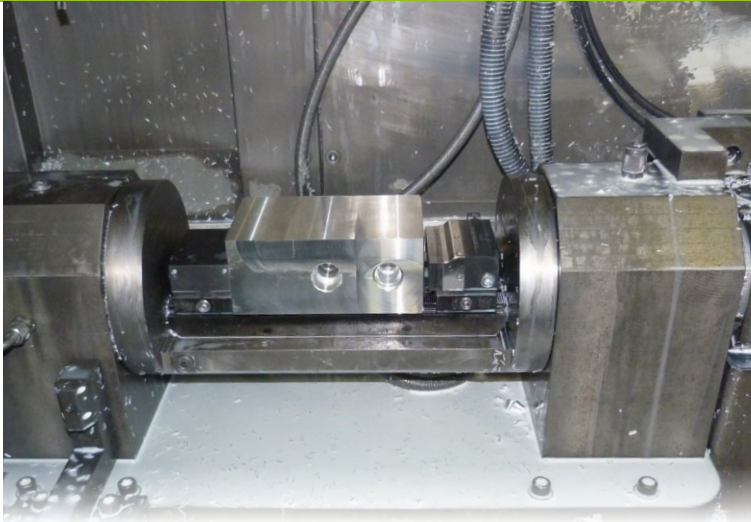

PSH1X 94L55-300	
1	1x TK120415
2	1x
3	2x PCSP 60R
4	2x PCSP 60L
5	2x PCS 14
6	2x PCGU 20 49
7	1x M6x8 ISO 7380
8	1x PCHA 01
9	5x M2,5x3 DIN 963
10	1x G 1/8A x11 BN45
11	1x 10x13,5x1 DIN 7603A BN447
kg	~2,3

	B300	B301	B302
C	94	94	94
H	29,5	29,5	29,5
i	HV700 x0,2mm	HV700 x0,2mm	*

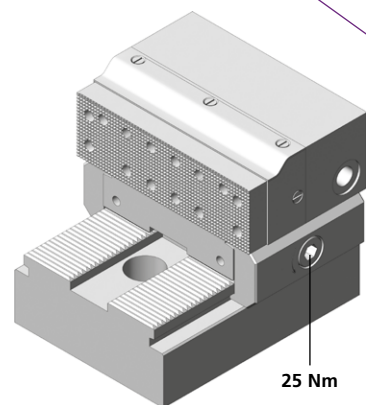

Bestellbeispiel / Ordering example / Exemple de commande: PSH1X 94L55-300 & 1 x B301

* = weich / soft / doux

Separat bestellen / Separate order / Commander séparément



Universalbacke / Universal jaw / Mors universel

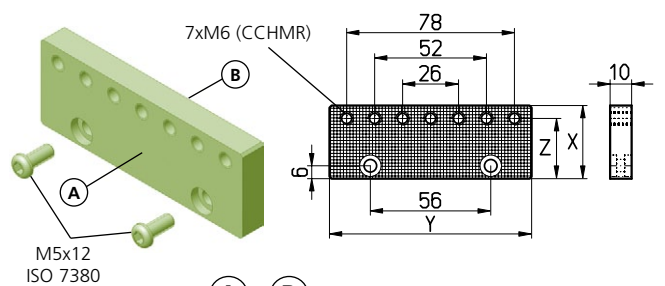

	A	B	X	Y	Z		kg
PC 9434			34	94	28	56 HRC	~ 0,24
PC 9449			49	94	43	56 HRC	~ 0,35
PC 12549			49	125	43	HV700 x 0,2mm	~ 0,47

weiche Backe / soft jaw / mors doux 1.0570

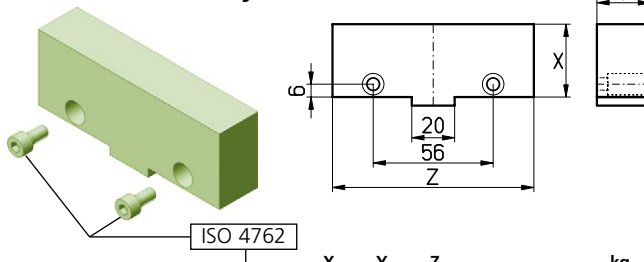

	X	Y	Z	kg	
PC 943425W	M5x25	34	25	94	~ 0,62
PC 943430W	M5x30	34	30	94	~ 0,75
PC 944930W	M5x30	49	30	94	~ 1,08
PC 1254930W	M5x30	49	30	125	~ 1,44

**Backe mit 2 Pendeldruckstücken
Jaw with 2 swiveling balls
Mors avec deux pièces de pression mobiles**

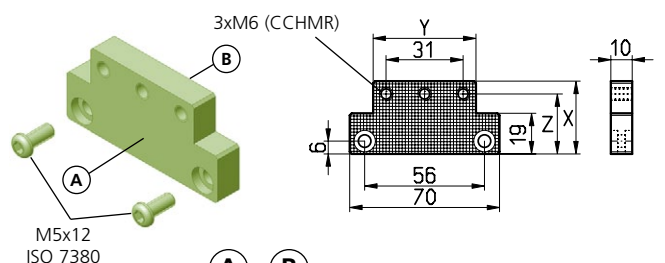

	A	B	X	Y	Z		kg
PC 4349			49	43	43	56 HRC	~ 0,20
PC 4834			34	48	28	56 HRC	~ 0,15

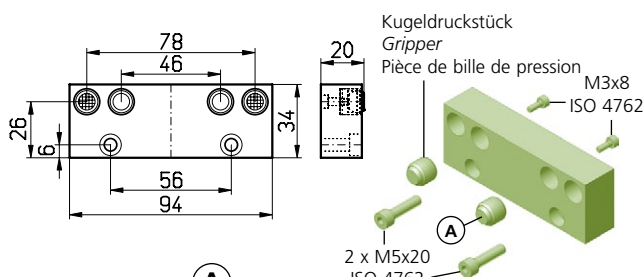

	A	kg
PC 9460		~ 0,45
PC 9460R		~ 0,45

Prismabacke / Prismatic jaw / Mors avec prisme

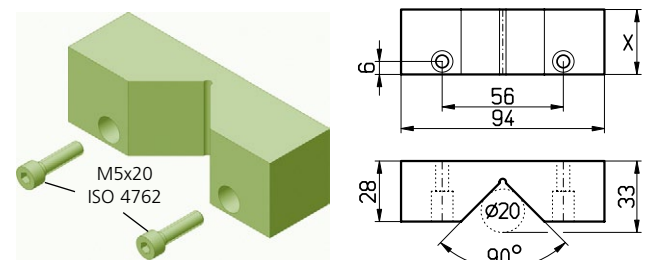

	X	kg
PC 9434 V90°	56HRC 34 min ø 6 max ø 52	~ 0,59

Prägebacke / Stamping jaw / Mors d'impression

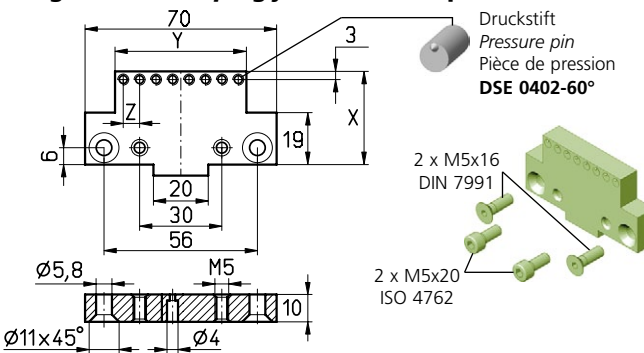

	X	Y	Z	kg
PC 4834 DS	34	48	7 x 6 = 42	~ 0,16
PC 4349 DS	49	43	6 x 6 = 36	~ 0,20
PC 4849 DS	49	48	5 x 8 = 40	~ 0,21

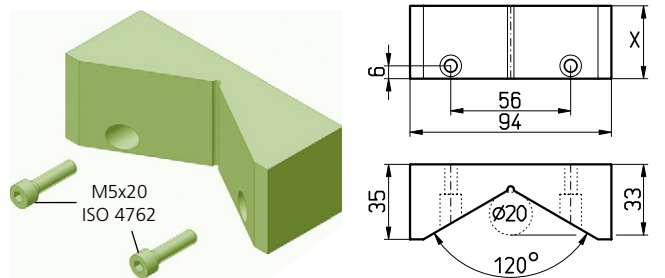

	X	kg
PC 9434 V120°	HV700 x0,2mm 34 min ø 8 max ø 158	~ 0,61
PC 9449 V120°	56HRC 49 min ø 8 max ø 158	~ 0,88

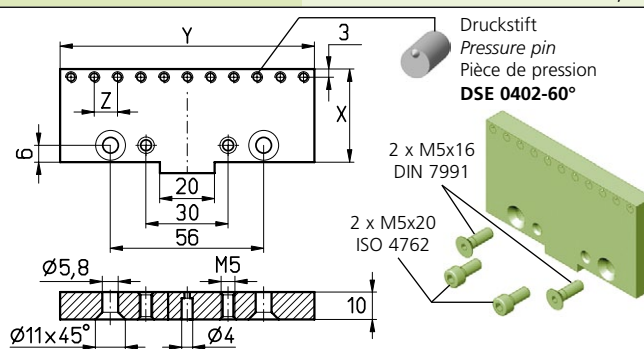

	X	Y	Z	kg
PC 9434 DS	34	94	10 x 5,8 = 85	~ 0,25
PC 9449 DS	49	94	10 x 5,8 = 85	~ 0,36
PC 12549 DS	49	125	13 x 8,5 = 110,5	~ 0,47



Universalbacke / Universal jaw / Mors universel

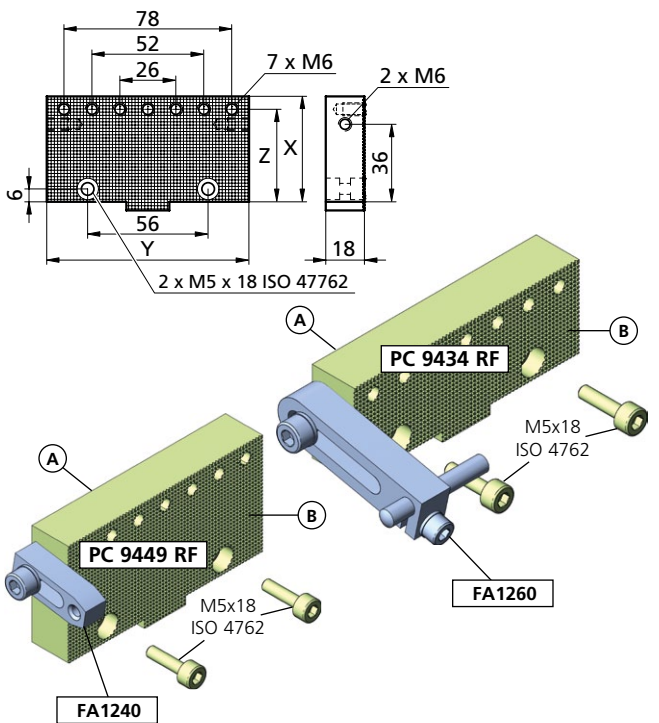

	A	B	x	Y	Z	kg
PC 9434 RF			34	94	28	HV 700 x 0,2mm ~ 0,24
PC 9449 RF			49	94	43	HV 700 x 0,2mm ~ 0,35

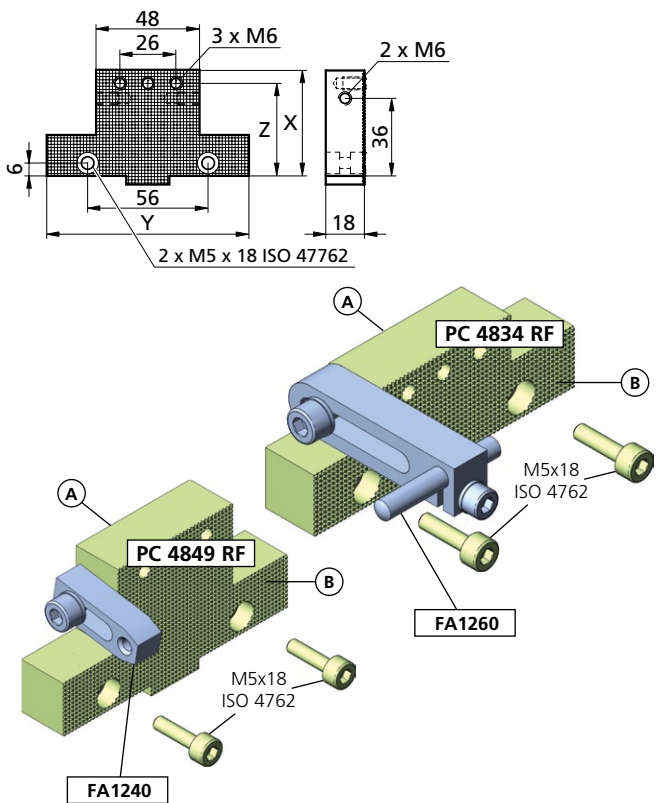

	A	B	x	Y	Z	kg
PC 4834 RF			34	94	28	HV 700 x 0,2mm ~ 0,43
PC 4849 RF			49	94	43	HV 700 x 0,2mm ~ 0,33

Universalbacke / Universal jaw / Mors universel

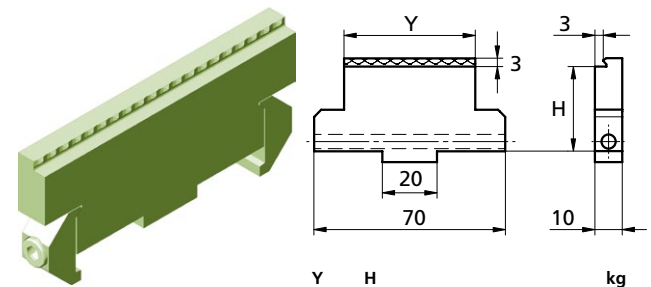

	Y	H	kg
PC 48-34 PRG	48	31	57HRc ~ 0,185
PC 48-49 PRG	48	46	57HRc ~ 0,241
PC 94-34 PRG	94	41	57HRc ~ 0,36
PC 94-49 PRG	94	46	57HRc ~ 0,48

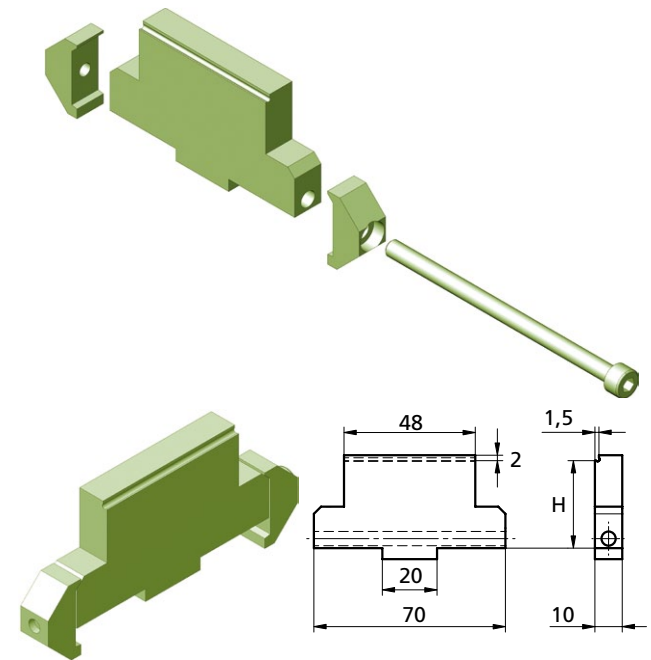

	H	kg
PC 4849-15	32	HV700 x 0,2mm ~ 0,25
PC 4834-15	47	HV700 x 0,2mm ~ 0,19

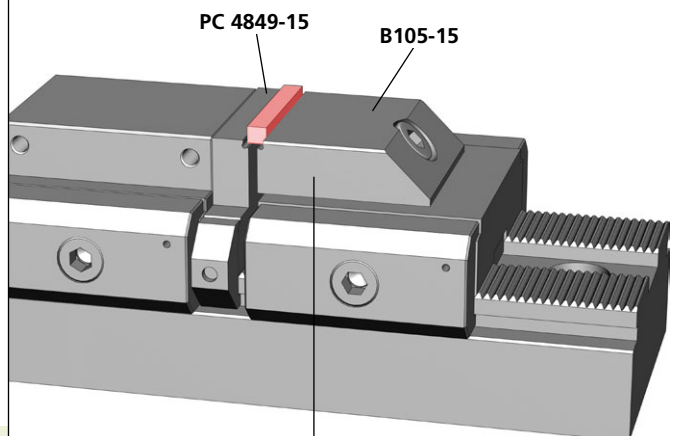

p. 96

Bestellbeispiel / Ordering example / Exemple de commande: PC 9434 RF & 1 x FA1240

Separat bestellen / Separate order / Commander séparément



Prismabacke / Prismatic jaw / Mors avec prisme

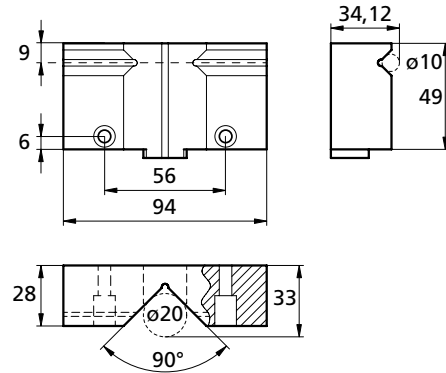
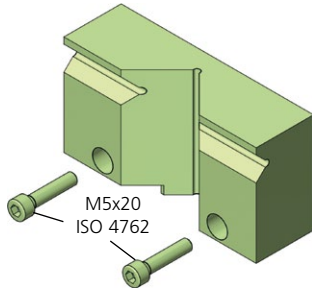

		X	kg
PC 9449 V90°-2	HV 700 x0,2mm	34	~ 0,84
		min ø 5	
		max ø 16	
		min ø 16	
		max ø 52	

Von Niederzug zu Linear!

From pull down jaws to linear stroke!

Mors abaissant et serrage linéaire parallèle!

PCL 4834 N

- 1 1x TF140698
- 2 2x FED 10175
- 3 2x PCD 0813
- 4 2x M5x20 BN 1392
- 5 1x PCGU 2028
- 6 1x PCGU 2030 LB
- 7 2x M6x8 ISO 7380
- 8 1x M10x22 ISO 4762

X = 34

Y = 48

kg ~0,366

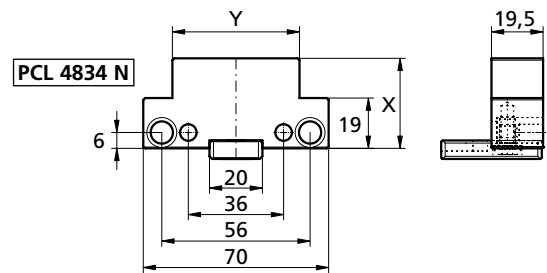
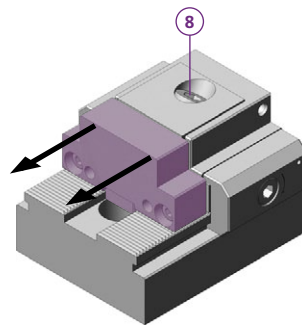

PCL 9434 N

- 1 1x TF140699

X = 34

Y = 94

kg ~0,536

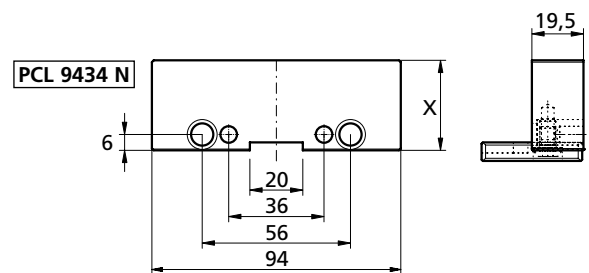
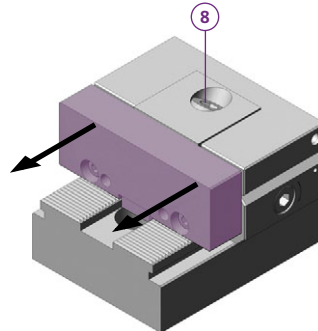

PCL 4349 N

- 1 1x TF140697
- 2 2x FED 10175
- 3 2x PCD 0813
- 4 2x M5x20 BN 1392
- 5 1x PCGU 2028
- 6 1x PCGU 2030 LB
- 7 2x M6x8 ISO 7380

X = 49

Y = 43

kg ~0,426

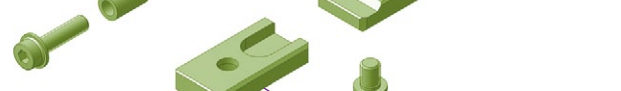
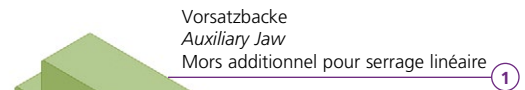
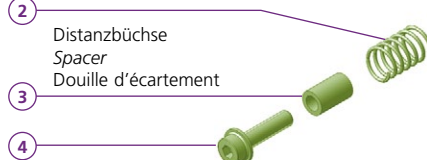

PCL 9449 N

- 1 1x TF140700

X = 49

Y = 94

kg ~0,730

PCL 12549 N

- 1 1x T00317

X = 49

Y = 94

kg ~0,962

Bestellbeispiel / Ordering example / Exemple de commande: PCL 4834 N



Click-Flex

PCFX 30 / PCFX 35 / PCFX 50 / PCFX 70

powerCLAMP

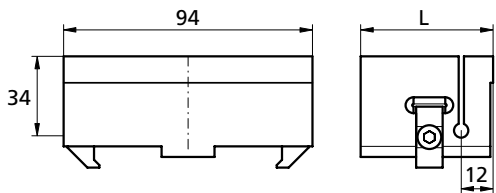

PCFX 30

- ① 1x TF140702
- ② 1x PCSP 10B
- ③ 1x PCSP 10G
- ④ 1x M5x85 DIN 912

L = 30
kg ~0,26

PCFX 35

- ① 1x TF140703

L = 35
kg ~0,30

PCFX 50

- ① 1x TF140704

L = 50
kg ~0,44

PCFX 70

- ① 1x TF140705

L = 70
kg ~0,62

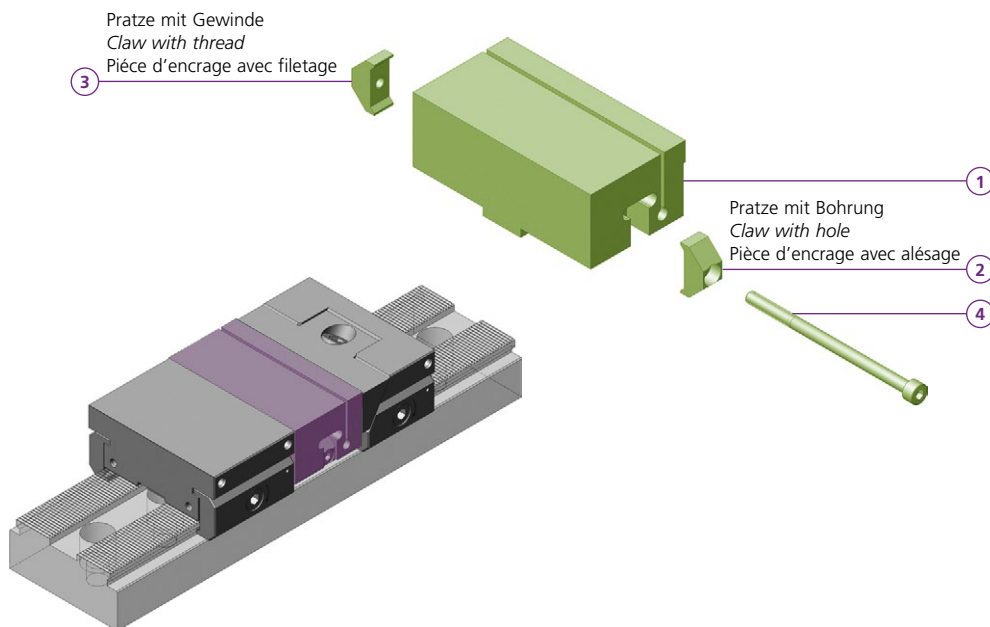

Bestellbeispiel / Ordering example / Exemple de commande: **PCFX 30**

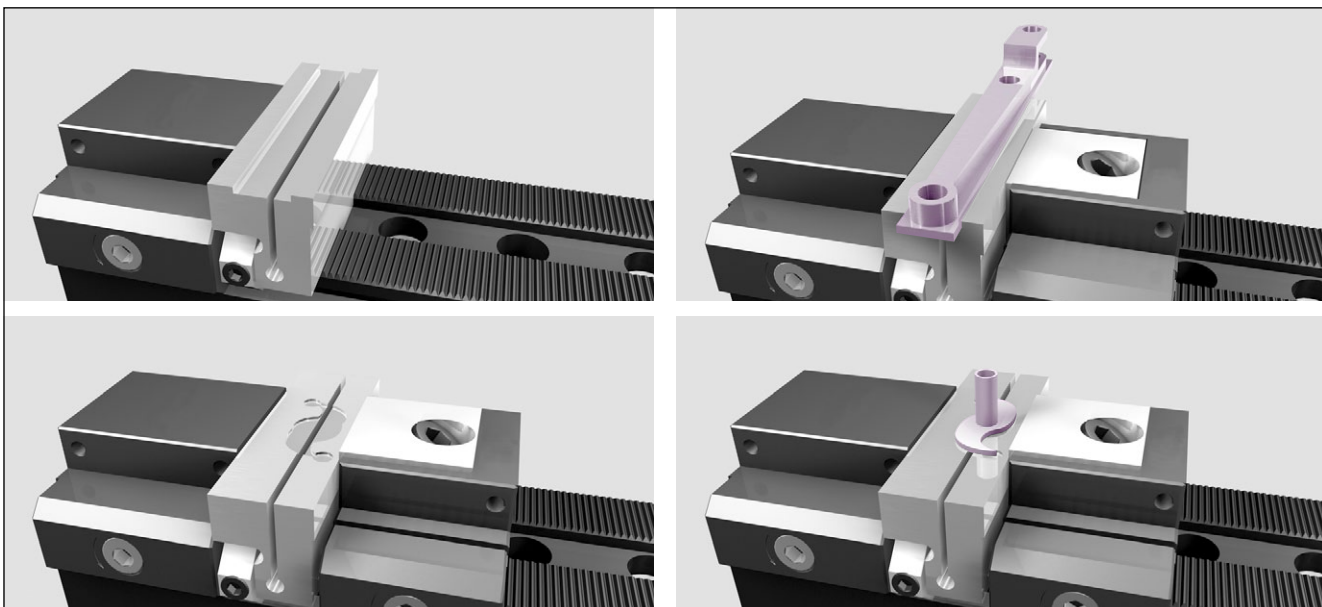
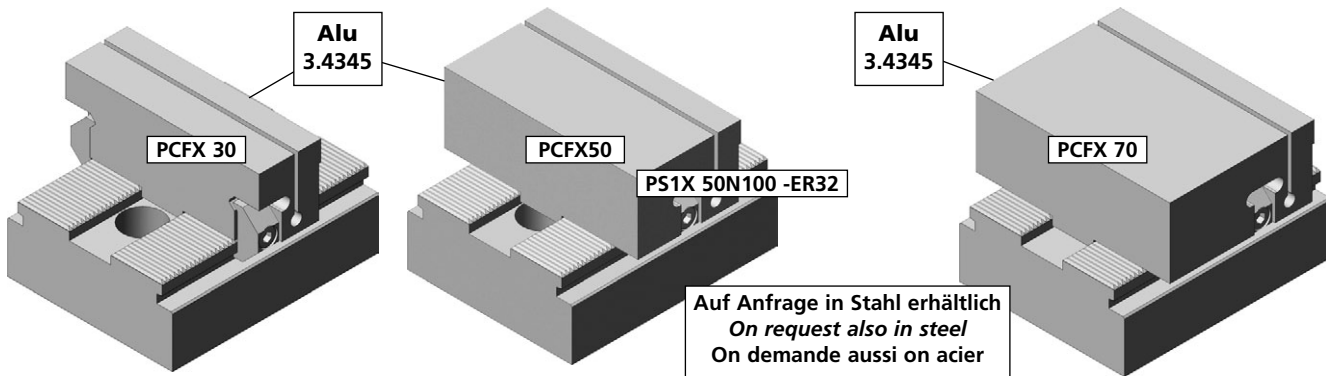

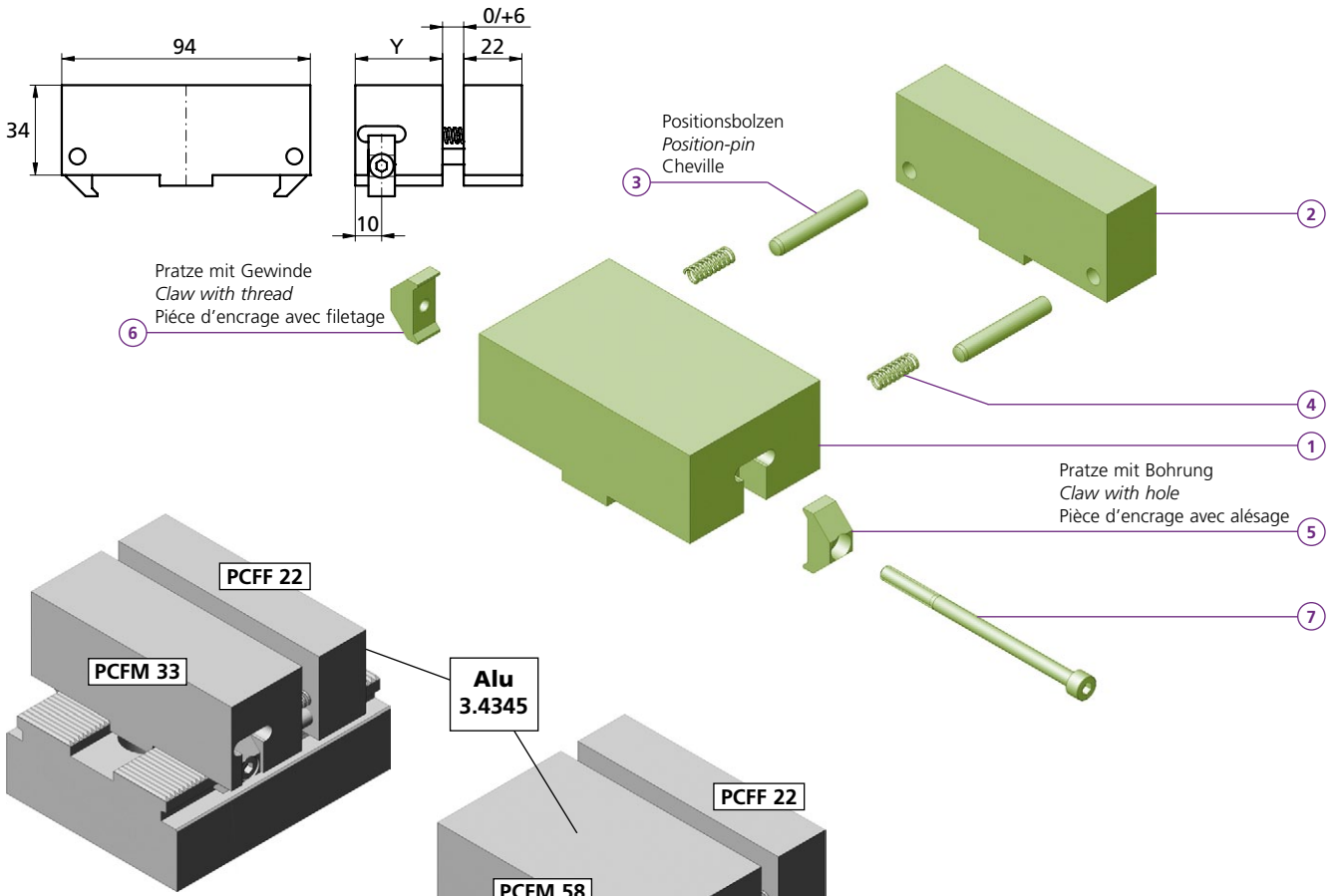

PCFM 33-22

- ① 1x PCFM 33
- ② 1x PCFF 22
- ③ 2x CCBO 0801
- ④ 2x FED 0618
- ⑤ 1x PCSP 10B
- ⑥ 1x PCSP 10G
- ⑦ 1x M5x85 D912

Y = 33
kg ~0,52

PCFM 58-22

- ① 1x PCFM 58

Y = 58
kg ~0,74

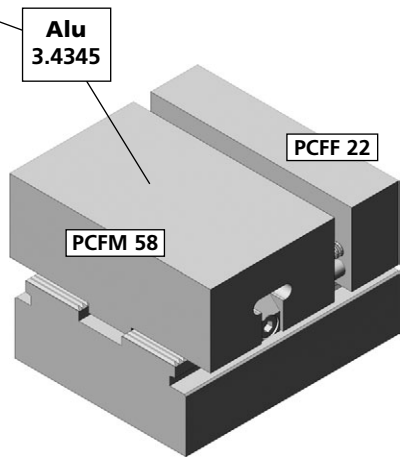

Auf Anfrage in Stahl erhältlich
On request also in steel
On demande aussi on acier

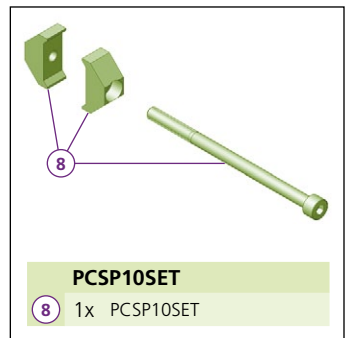

PCSP10SET

- ⑧ 1x PCSP10SET

Bestellbeispiel / Ordering example / Exemple de commande: **PCFM 33-22**

Anschlagbacke flach
Jaw flat stop
Plaqué d'appui lisse

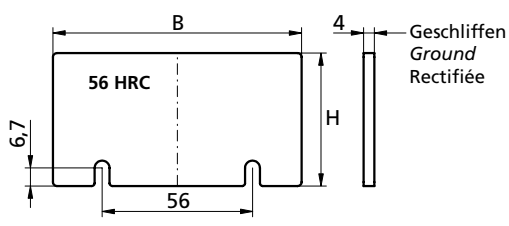

H	Module 93mm	B
34	PCUD 34093TG	93
49	PCUD 49093TG	93

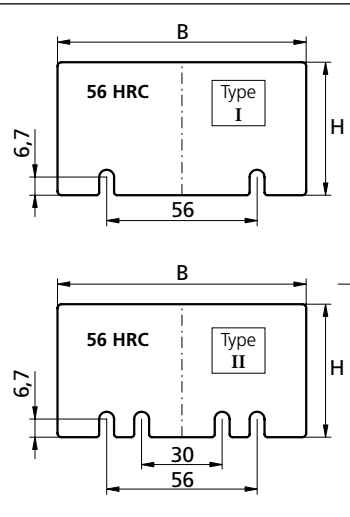

Unterlagen gehärtet und geschliffen
Parallels hardened and ground
Cales trempés et rectifiées

H	94mm	B	Type
14	PCUD 14093	93	I
20	PCUD 20093	93	I
24	PCUD 24093	93	I
29	PCUD 29093	93	I
31	PCUD 31093	93	II
34	PCUD 34093	93	I
39	PCUD 39093	93	I
44	PCUD 44093	93	I
46	PCUD 46093	93	II
47	PCUD 47093	93	I

Niederzugbacke für Anschlagseite Pull down jaws for solid reference face Mors plaquant sur la face solid



powerCLAMP

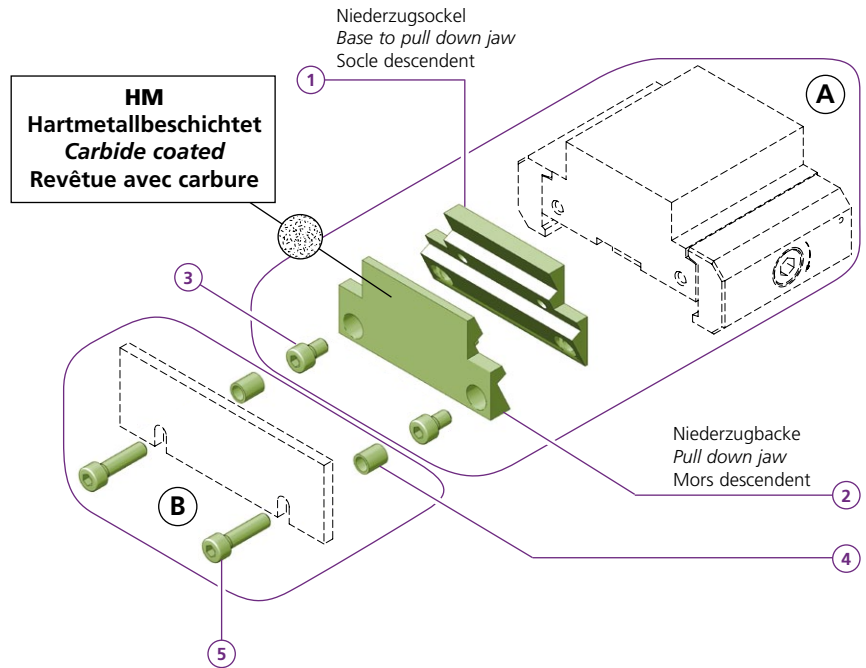
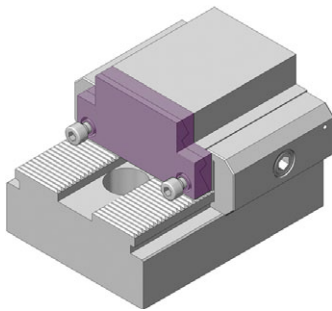
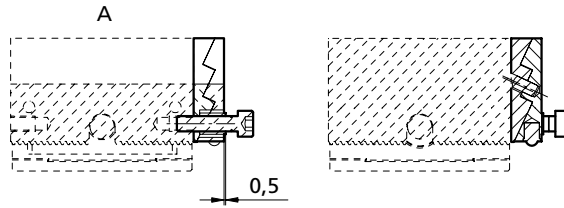
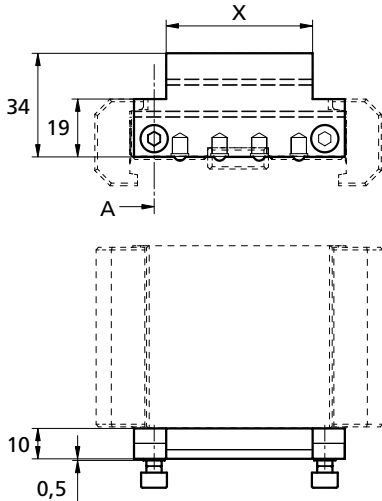

- PC 4834 N**
- ① 1x PC4834NSL
 - ② 1x PC4834NB1
 - ③ 2x M5x8 ISO 4762
 - ④ 2x PCD 008
 - ⑤ 1x M5x20 ISO 4762
 - X = 48
 - kg ~0,17

- PC 9434 N**
- ① 1x PC9434NSL
 - ② 1x PC9434NB1
 - X = 94
 - kg ~0,22

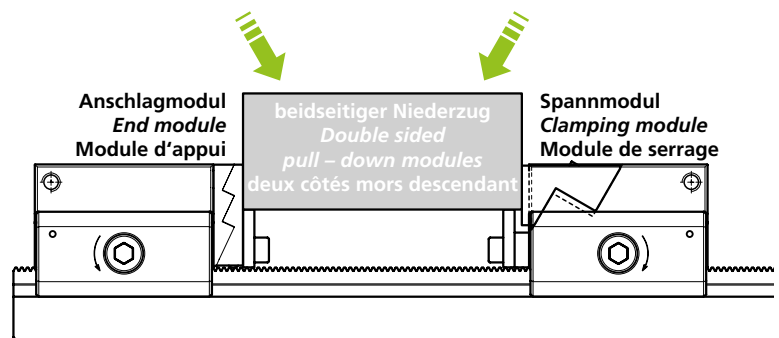

Bestellbeispiel / Ordering example / Exemple de commande: **PC 4834 N**

**Magnetunterlage
Magnetic base
Cale magnétique**

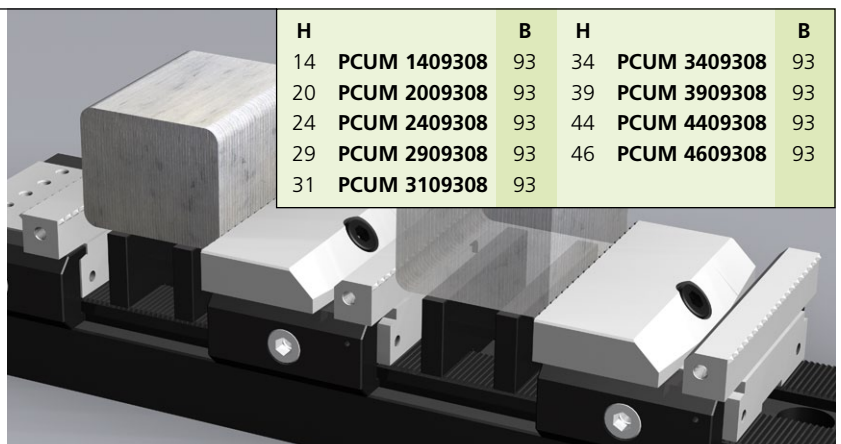
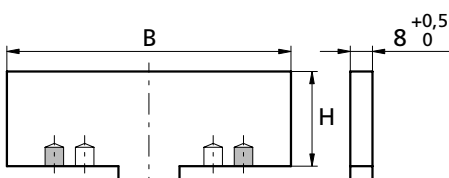

Parallelunterlage Steel parallels Cales parallèles



powerCLAMP

H	B	H	B	H	B	H	B	H	B	Type
19mm		34mm		48mm		61mm		94mm		
20 PCU 20018	18	20 PCU 20033	33	20 PCU 20047	47	20 PCU 20060	60	14 PCU 14093	93	I
24 PCU 24018	18	24 PCU 24033	33	24 PCU 24047	47	24 PCU 24060	60	20 PCU 20093	93	I
29 PCU 29018	18	29 PCU 29033	33	29 PCU 29047	47	29 PCU 29060	60	24 PCU 24093	93	I
31 PCU 31018	18	31 PCU 31033	33	31 PCU 31047	47	31 PCU 31060	60	29 PCU 29093	93	I
34 PCU 34018	18	34 PCU 34033	33	34 PCU 34047	47			31 PCU 31093	93	II
39 PCU 39018	18	39 PCU 39033	33	39 PCU 39047	47			34 PCU 34093	93	I
44 PCU 44018	18	44 PCU 44033	33	44 PCU 44047	47			39 PCU 39093	93	I
46,5 PCU 46518	18	46 PCU 46033	33	46 PCU 46047	47			44 PCU 44093	93	I
		46,5 PCU 46533	33					46 PCU 46093	93	II
								47 PCU 47093	93	I
H	B	H	B	H	B	H	B	H	B	Type
26mm		43mm		58mm		78mm		125mm		
20 PCU 20025	25	20 PCU 20042	42	20 PCU 20057	57	20 PCU 20077	77	20 PCU 20124	124	
24 PCU 24025	25	24 PCU 24042	42	24 PCU 24057	57	24 PCU 24077	77	24 PCU 24124	124	
29 PCU 29025	25	29 PCU 29042	42	29 PCU 29057	57	29 PCU 29077	77	29 PCU 29124	124	
31 PCU 31025	25	31 PCU 31042	42	31 PCU 31057	57	31 PCU 31077	77	31 PCU 31124	124	
34 PCU 34025	25	34 PCU 34042	42			34 PCU 34077	77	34 PCU 34124	124	
39 PCU 39025	25	39 PCU 39042	42			39 PCU 39077	77	39 PCU 39124	124	
44 PCU 44025	25	44 PCU 44042	42			44 PCU 44077	77	44 PCU 44124	124	
46,5 PCU 46525	25	46 PCU 46042	42					46 PCU 46124	124	
		47 PCU 47042	42							

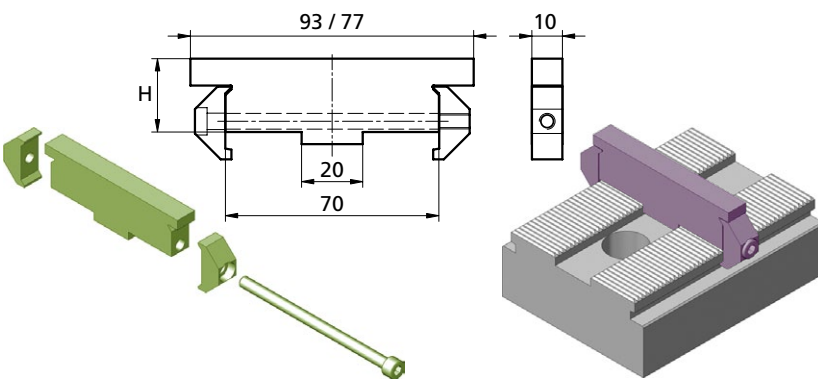
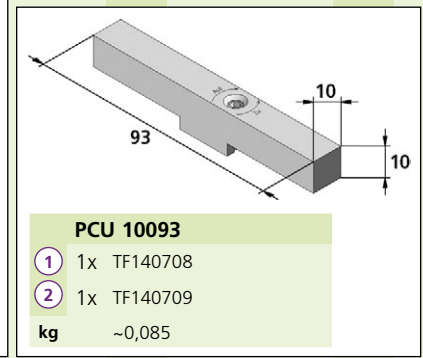
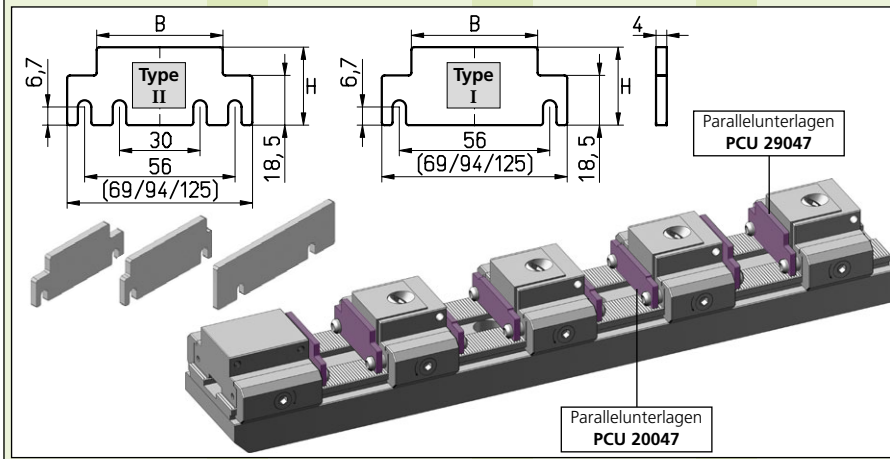

weich soft doux	1.7225	hart hardened dur	HRC55
	H +0,15 +0,25		H ± 0,005
PCU 20077B10-W	20	PCU 20077B10	20
PCU 24093B10-W	24	PCU 24093B10	24
PCU 39093B10-W	39	PCU 29093B10	29
PCU 44093B10-W	44	PCU 31093B10	31
PCU 46093B10-W	46	PCU 34093B10	34
		PCU 39093B10	39
		PCU 44093B10	44
		PCU 46093B10	46

Unterlagen- und Fräsanschlaghalter Holder for parallels and workpiece stop Cale et support pour butée de fraisage

