



# MACHINERY

Eliminate costly secondary setups  
and additional parts handling.

NCY-32M

NCY-36M

# SLIDING HEAD CNC LATHE

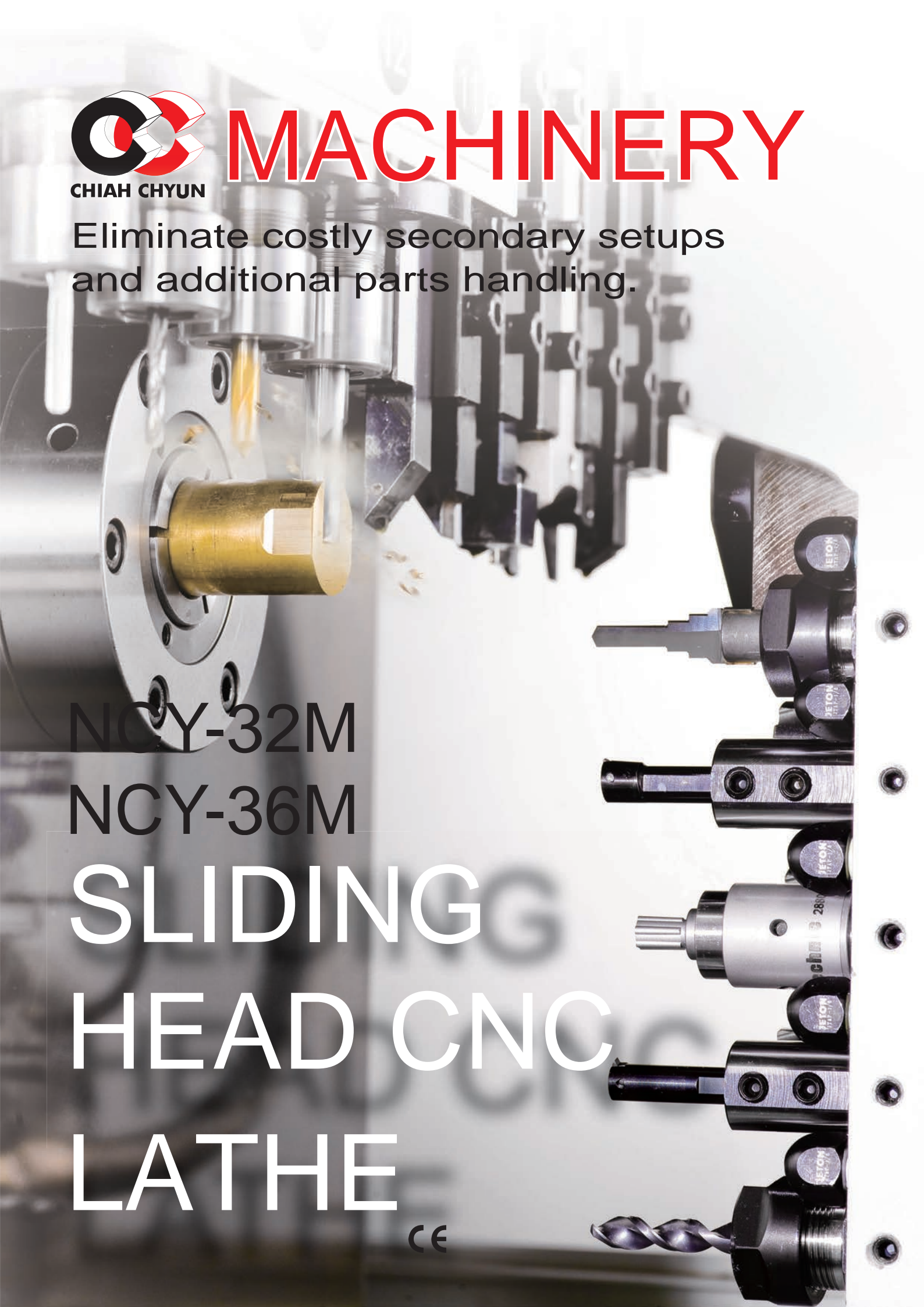





# Cuts Machining Cost Increases Productivity and Profit!

With the Sliding Head CNC Lathe from Chua Chyun, you can perform turning, milling, drilling, tapping, cutting and slide turning in one operation. Sliding headstock design combined with PC-based CNC control offer extra high efficiency and precision machining.

# NCY

- Sliding headstock design.
- $\varnothing 36$  /  $\varnothing 32$ mm bar capacity.
- X, Y, Z-axis rapid traverse 30m/min.
- Linear ways on X, Y, Z-axis.
- 4,000 rpm spindle is standard.
- 6,000 rpm spindle is optional.
- PC-based CNC control.
- Ruggedly constructed cast iron base.

# Applications:

Designed for various precision parts machining, such as:

- Automotive, motorcycle and bicycle parts.
- Electronic and electrical parts.
- Instrument parts.
- Pneumatic and hydraulic parts.
- Sanitary and toilet wares.
- Hardware.
- Any other precision parts.





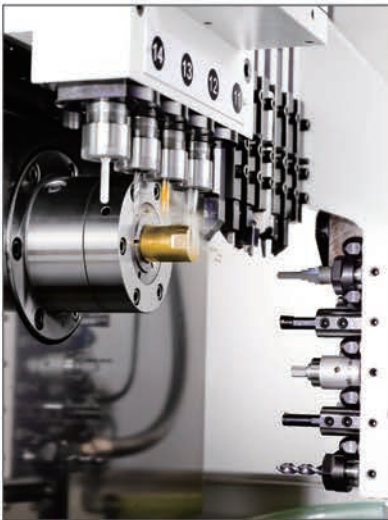
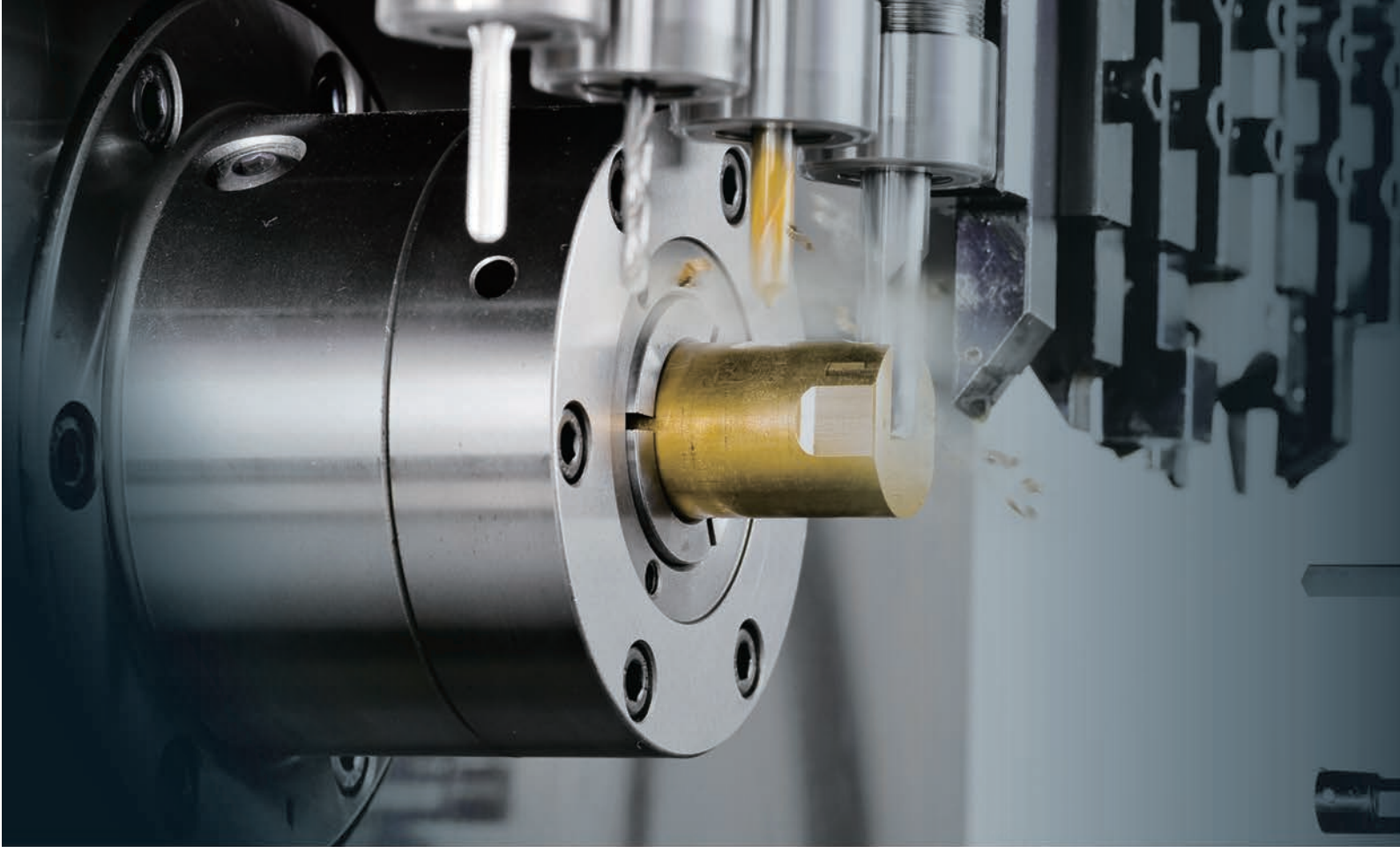

## Main Tool Slide (Standard)

- The main tool slide is mounted at top of the headstock.
- It can be fitted with 6 O.D. tools with 12mm tool shank.
- The main tool slide is suitable for turning outside diameter of workpiece.



## C-Axis Contouring Capability (Standard)

- The C-axis features contouring capability.
- Employs a 12-person driven tool by a servo motor.
- Rotating tool holders and tools are optional.
- 0.001 mm extra high indexing resolution ensures high precision contouring and indexing.

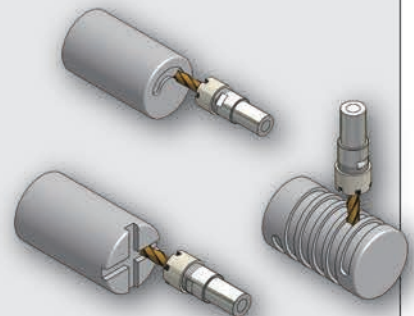

# Multiple Tooling Systems for Versatile Cutting Applications

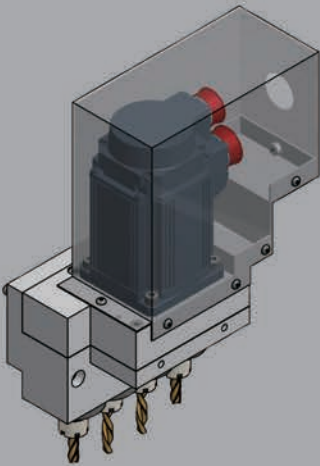
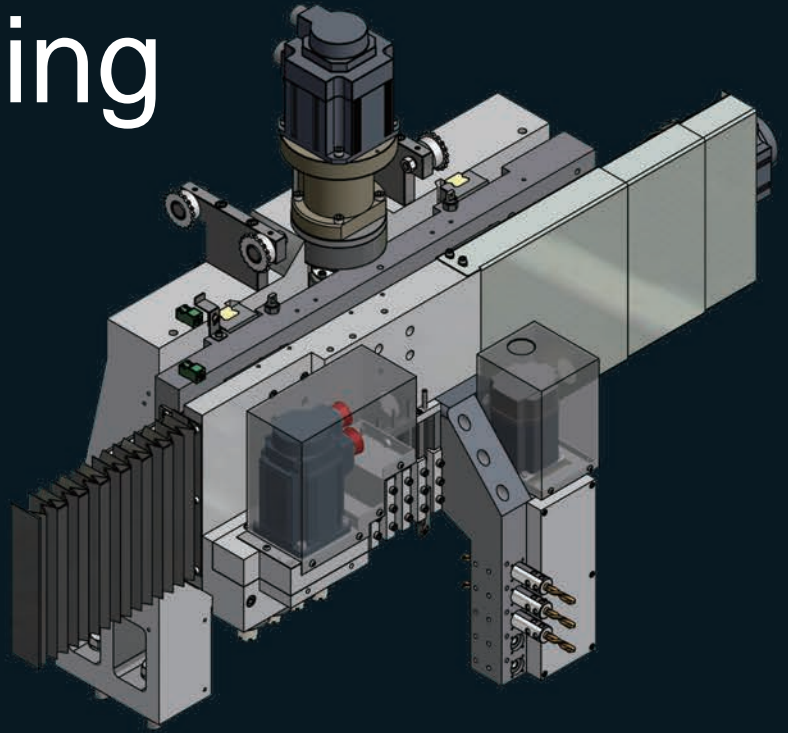

## Side Milling Device (Standard)

- The side milling device is mounted at left side of the headstock.
- The device is suitable for side milling, drilling and tapping operations.
- Total 4 powered tools driven by a servo motor.
- Max. tool speed is 6,000 rpm.

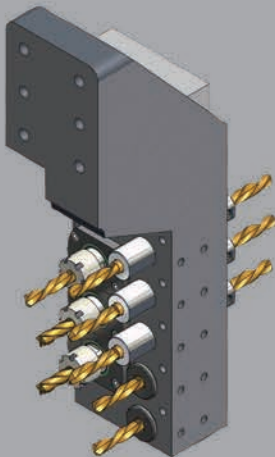

## End Milling Device (Optional)

- The end milling device is mounted in front of the head stock.
- The device is suitable for front end milling, drilling and tapping operations.
- Total 8 tools, among which 3 tools are powered and 5 tools are static.
- Powered tools are driven by a servo motor.
- Max. tool speed is 6,000 rpm.





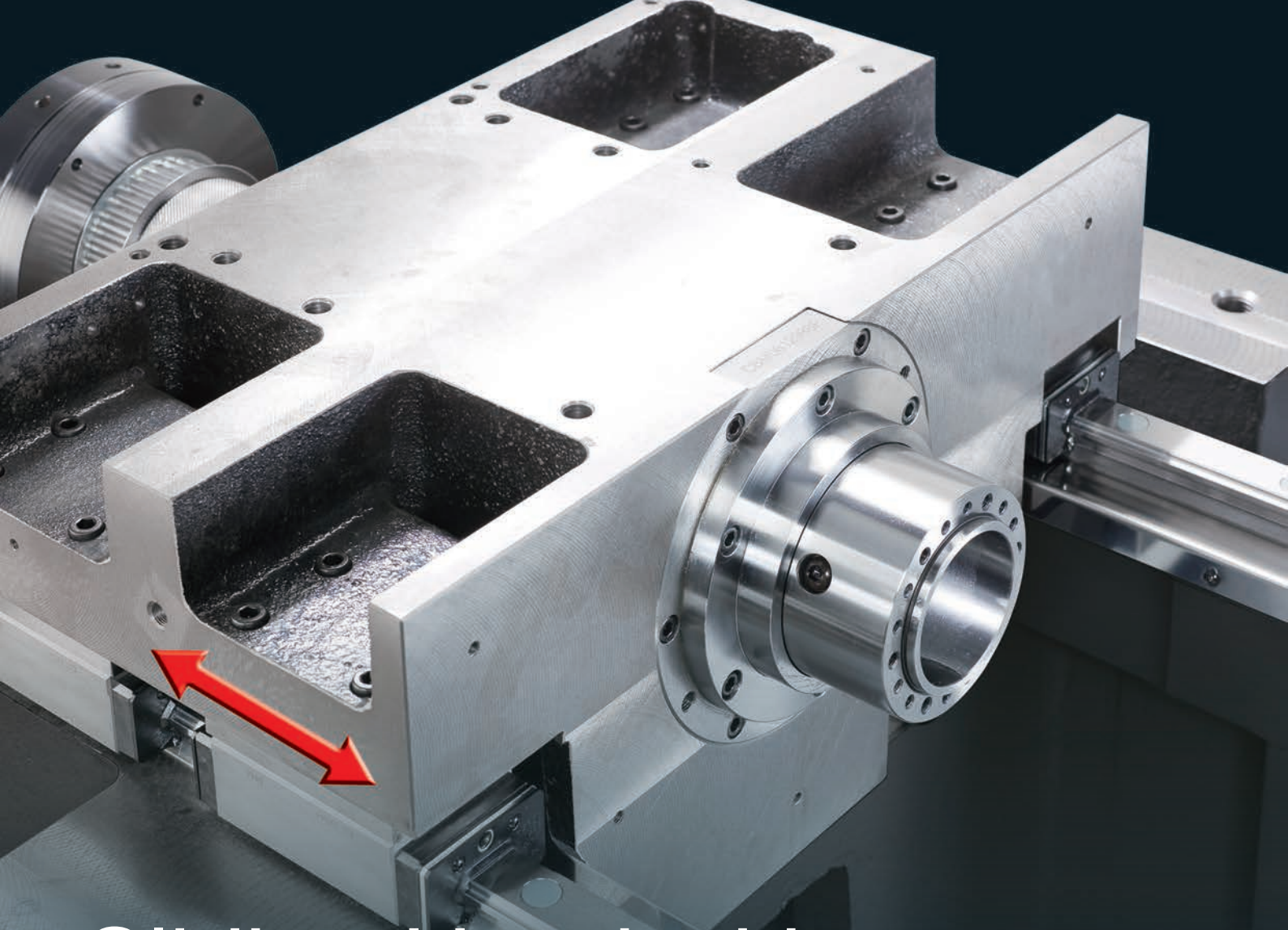

# Sliding Head without Guide Bush

Reducing your part handling and  
Maching setups

Spindle head moves on two precision linear ways combined with extra large span between ways, exhibiting outstanding stability and high positioning accuracy.

Provides additional costs saving, unlike like swiss-style machines. Savings include:

- Faster Setups (No guide bushing to setup)
- Shorter Remnants (No guide bushing, remnant limited to collet length)
- No ground stock needed (No guide bush)

## Built-In Spindle

High speed and high accuracy.  
Easily disassembling, quick repairing

- Performance range: 5.5kw-7.5kw
- Speed range: 6000rpm
- Clamping system: collet

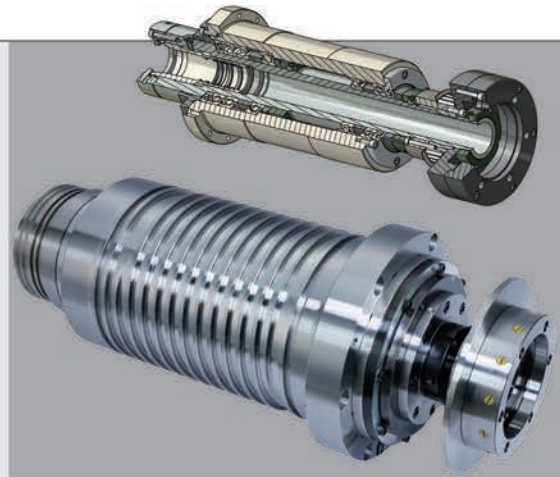

## Auxiliary Tailstock

(Optional)

With the optional auxiliary tailstock, the machine is allowed to cut longer parts. The ruggedly constructed tailstock holds part firmly.

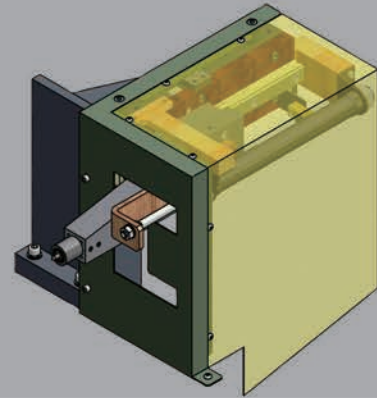

## Collet Chucking System

The collet chucking system provides a choice .

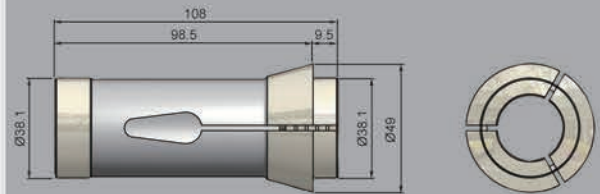

## Rock-Solid Base Structure

- The massive base is manufactured from high quality cast iron (FC-30), tempered and stress relieved to ensure material stability year after year.
- The one-piece fabricated base combined with rib reinforcement offer a solid support for the machine.

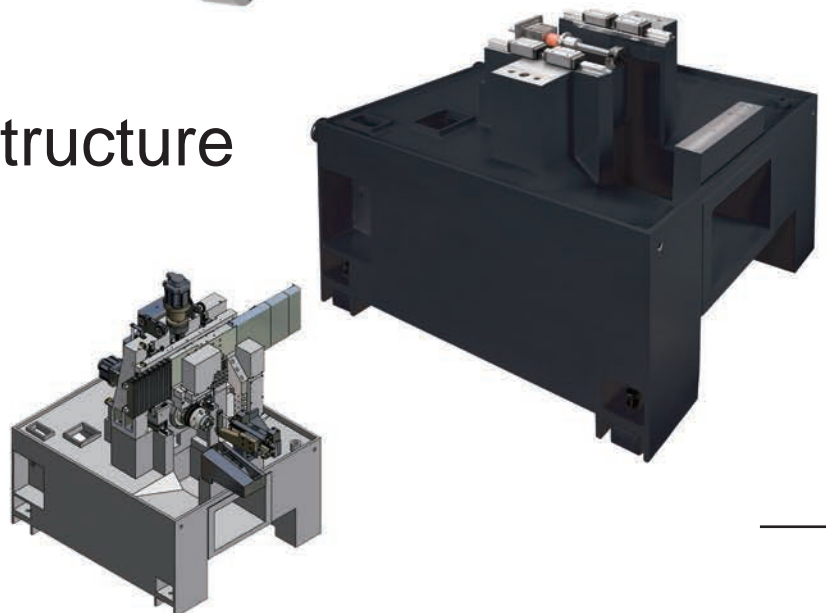

## Various Controller Interfaces

The controller is provided with various interfaces for program saving, loading and software updating, including:

- CF memory card
- USB
- Ethernet



## Chip Conveyor (Optional)

- Screw Type Chip Conveyor with Cart
- Steel Belt Chip Conveyor with Cart



## Auto Bar Feeder (Optional)

When an auto bar feeder (optional) is used together with the machine, it may perform fully automatic operation. The bar feeder dramatically upgrades production efficiency, while saving labor costs.





# Finished Parts Catcher and Collection Box

After parts are machined, they will fall down into a parts catcher, then slide into a collection box. It allows operator to collect finished products conveniently.



# Hydraulic Power Unit

- The hydraulic power unit provides fast and stable workpiece clamping.
- The hydraulic power unit is fan cooled to maintain a constant temperature.



# Heat Exchanger for Electrical Cabinet

The heat exchanger is provided to maintain a constant temperature in the electrical cabinet. This ensures stable control performance, and long service life of electronic parts.



## INTERFERENCE DIAGRAM

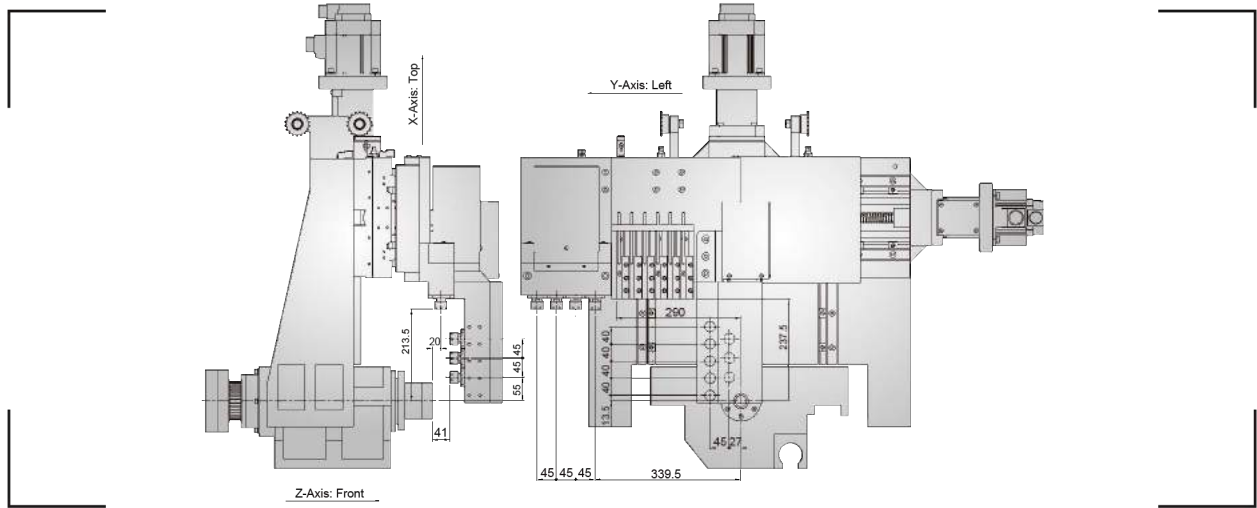

## TOOLING SYSTEM

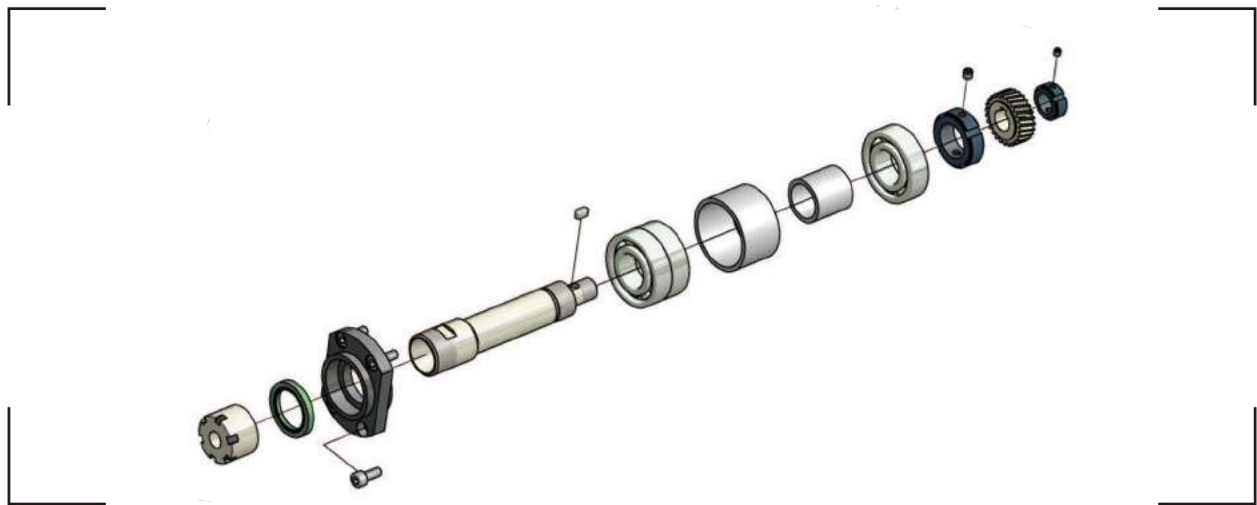

## MACHINE DIMENSIONS

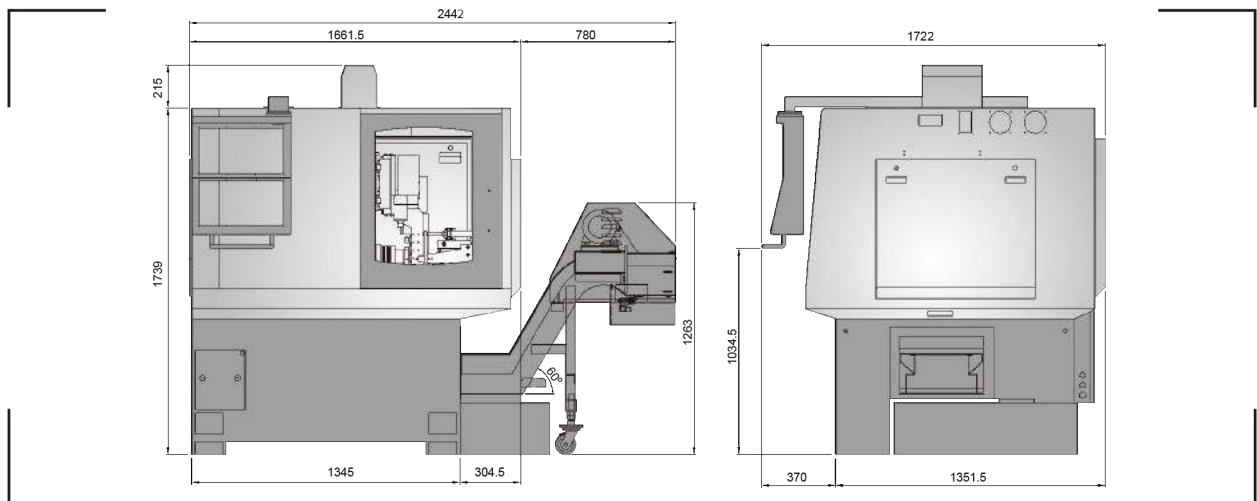



MACHINE SPECIFICATIONS	NCY-32M	NCY-36M
Max. manu. dia.	Ø32	Ø36
Spindle max. rpm.	6000 rpm	
Spindle center height	1015	
Max. bar feeding dia.	Ø32	Ø36
Collet of spindle	TRB-32	TRB-36
Spindle servo motor	7.5 kw	
No. of O.D. turning tools	6(Option:5)	
No of I.D. turning tools	5	
O.D turning tool size	12 x 12 x 120 (Option 16 x 16 x 120)	
I.D. turning tool size	Ø25	
X, Y, Z-axis travel	190/490/165	
X, Y, Z rapid travel speed	30 m/min	
X, Y, Z-axis servo motor	X:1.3kw, Y/Z:0.85 kw	
No. of radial live tooling	4	
Radial tooling size	ER-20	
Radial live tooling servo motor	1.0kw	
Radial live tooling max. speed	6000 rpm	
No. of axial live tooling	3	
Axial tooling size	ER-20	
Axial live tooling max. speed	0.75 kw	
Machine size(LxWxH)(Includes chip conveyor)	2442x1954x1722	
Machine N.W(Includes chip conveyor)	3100 kgs	
Spindle & Sub spindle coolant pump	1 HP	
Auto lubricator capacity	3~6 cc/15 min	

#### OPTIONAL ACCESSORIES

- Cross side turning tool device
- Front side turning tool device
- Auto spiral chip conveyor & cart
- Steel belt chip conveyor & cart
- Voltage stabilizer / transformer
- Tailstock(s)
- Air-blowing device
- Spindle motor R.P.M to 6000 rpm
- Spindle motor upgraded to 5 kw & 4000 rpm

#### STANDARD ACCESSORIES

- Tool kit & box
- Drilling shaft 20×5
- Collet chuck device
- Auto bar feeder interface
- Finished parts catcher
- Cutting fluid device
- Auto power breaker
- Hydraulic cylinders stroke
- Inspection device
- Cutting fluid inspection device
- Control pendent



**CHIAH CHYUN MACHINERY CO., LTD.**

No. 16, Lane 52, Sanshe Rd., Shengang Dist.,  
Taichung City 42944, Taiwan.

TEL: +886-4-2533-7614 FAX: +886-4-2532-9524

E-mail: [info@chiah-chyun.com](mailto:info@chiah-chyun.com)

<http://www.chiah-chyun.com>