

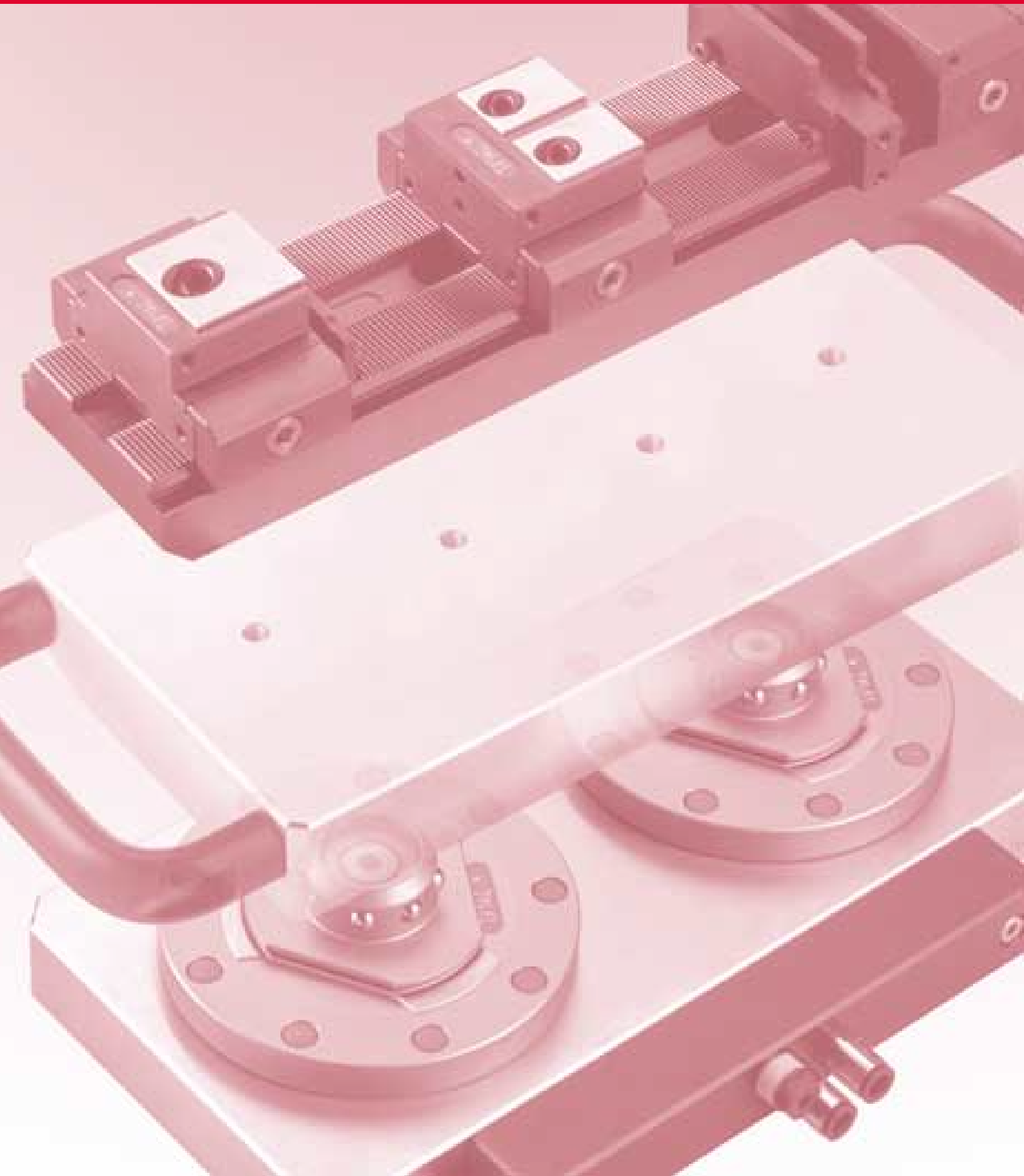







oppSystem

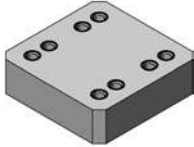

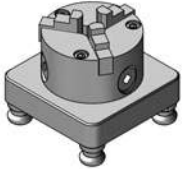

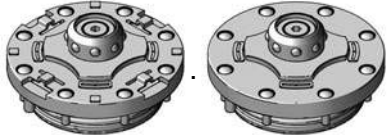
 Einleitung Introduction	281 - 283
Anwendungsbeispiele Examples of application	284 - 285
Mechanisches Nullpunktsystem mit diversen Spannlösungen Mechanical zero point system with different workholding solutions	286
0-Punkt Schnellwechselsystem Mechanical zero point system Universal Flansch Universal flange	287
	
0-Punkt Erhöhung Zero point riser	288
	
Ausrichtplatte Alignment plate	289
	
Dreibackenfutter Three-jaw chuck	290
	
Klemmbüchse Clamping-case	291
	
Zentriereinheit Chuck unit	292
	
Palettenträger Receiver chuck with chucks	293
	
MTS Palettier-System MTS palleting system	297 - 300
Zubehör Accessoires	301 - 302
	



Nullpunkt-Palettiersystem

Zero-point palleting system

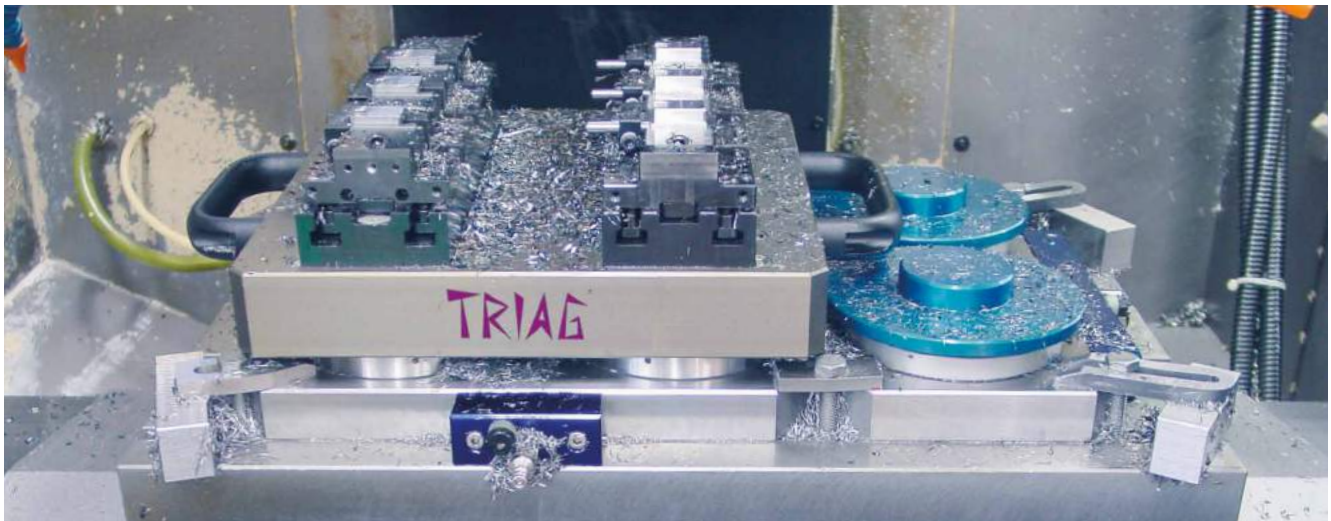

In den letzten Jahren wurden die Werkzeugmaschinen viel leistungsfähiger. Damit wurden die Bearbeitungszeiten wesentlich kürzer. Aufgrund der vom Auftraggeber verlangten Lieferzeiten („Just-In-Time“) sind aber die Losgrößen geringer geworden, was zu vermehrten Einrichtzeiten führt.

The productivity of modern machining centers has been drastically increased over the past years. Hence the time per workpiece is falling. On the contrary the batch sizes are getting smaller due to the increasing trend to „just in time“ production.

Auch die technisch hochentwickelten Maschinen sind jedoch immer noch mit einem T- Nuten Tisch ausgerüstet. Die Befestigung und das Ausrichten des zu bearbeitenden Werkstückes auf dem T-Nutentisch kann nur während der (teuren) Maschinen-Stillstandszeit erledigt werden. Diese Unproduktivität kumuliert sich, wenn die Werkstückbearbeitung mehrere Maschinenprozesse und somit mehrmaliges Befestigen und Ausrichten erfordert.

This means that the machine must be set up more frequently. Is the machine not equipped with a pallet changer, the set up and the changing of workpieces may only be accomplished during the stand still of the machine. This idling of the machine results in the loss of costly productive machine time. As it is, the aim of any machining facility to keep the spindle turning, the unproductive time must be minimized. As any machinist knows, the set up and alignment of workpieces on a T-slot table is very awkward and time consuming.

Die Lösung, die wir Ihnen für dieses Problem bieten, ist unser neuartiges, modulares Palettiersystem, das oppSystem.

The TRIAG opp (Zero-Point-Palleting) System represents an ideal interface between machining table and workholding device.

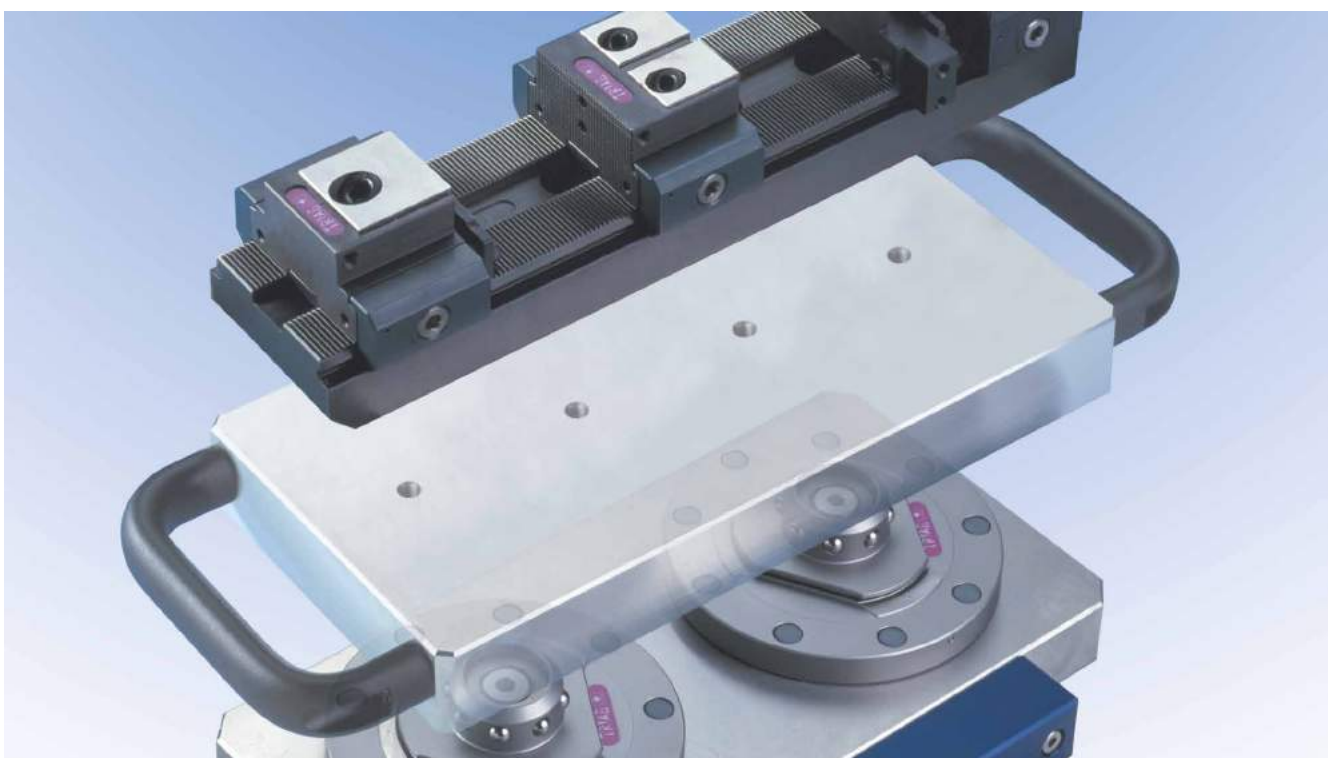



Das System besteht aus dem auf dem Maschinentisch der Werkzeugmaschine montierten Palettenträger und mindestens zwei Paletten oder mit Zentrier- und Klemmbüchsen ausgerüsteten Werkstückträgern. Die sehr präzise gefertigte Schnittstelle zwischen dem Palettenträger und der Palette ermöglicht ein sekundenschnelles Ein- und Auswechseln der Paletten, auf welcher ausserhalb der Werkzeugmaschine das zu bearbeitende Werkstück montiert und positioniert wird. Es wird eine sehr hohe Ausnutzung der theoretisch zur Verfügung stehenden Maschinenlaufzeit erreicht. Dies erhöht die Produktivität der Maschine und damit die Wirtschaftlichkeit des ganzen Betriebes.

Im Gegensatz zu vielen anderen Palettiensystemen auf dem Markt ist die Dimension des oppSystems in Form von Stichmassen genormt und richtet sich damit nach den individuellen Werkstückdimensionen. Die patentierte Konstruktion erlaubt überdies auch die unbemannte Be- und Entladung mit Hilfe eines Beschickungsgerätes.

Mit dem oppSystem sind 150'000 Spannungen ohne Referenzverlust möglich, bei einer Repetiergenauigkeit von $\pm 0,002$ mm. Das Lösen erfolgt pneumatisch mit ca. 6 bar, womit keine Mehrkosten für Hydraulikaggregate entstehen. Eine allfällig entstehende Wärmeausdehnung wird über die federnde Zentrierung kompensiert. Alle wichtigen Bauteile sind wartungsarm, leicht zu überprüfen und im Bedarfsfall einfach auszutauschen.

On the machine table the receiver chuck is installed. This chuck may consist of one, two, four, six or more receiver units. Onto these air operated receiver chucks a pallet, a fixture or a vice is mounted within a matter of seconds. On the bottom surface of the workholding devices centering rings are inserted. These centering rings are ground to a very high accuracy permitting the locking down of the workholding device with a repeatability of ± 0.002 mm on all three axes. The chucks are locked by spring force and unlocked by compressed air of 6 bar. This means that no hose connection is necessary during machining. Hydraulic pumps or hydraulic amplifiers are superfluous.

The patented oppSystem allows for 150'000 locking and unlocking cycles without loss of positioning accuracy. If necessary, the changing of the pallet may be accomplished by a robot or a handling system. Thermal expansion is compensated for by the spring loaded centering units.

Due to the unique oppSystem it is possible to bring the loading and unloading of the actual workpiece out of the machine which guarantees a maximum of productive machine time. Maintenance is simple as all components are easily accessible and replaceable. There are standard receiver chucks and pallets available with two or four receiver units. For other solutions or dedicated fixture you should contact TRIAG or your nearest dealer.

SMK30-17-42 OPP200 ~ 142 kg

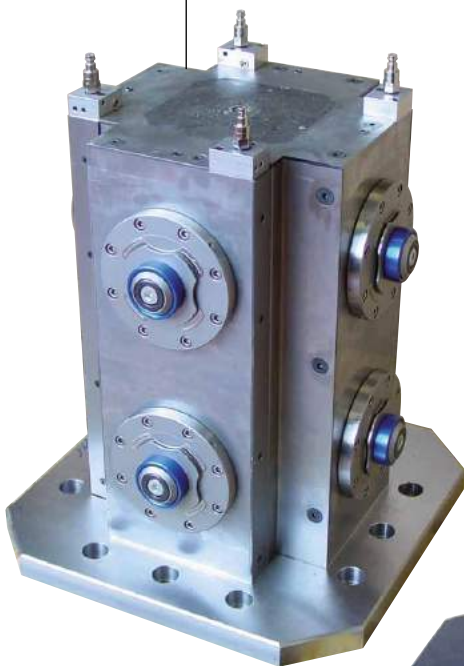

SMK24-24-42 OPP200 ~ 120 kg

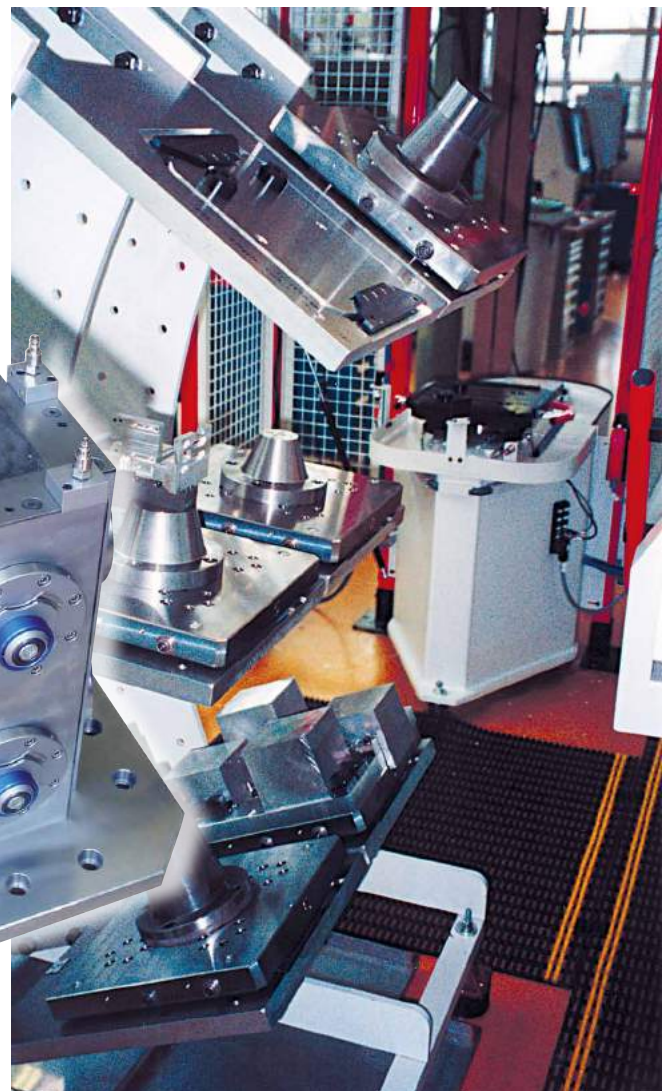
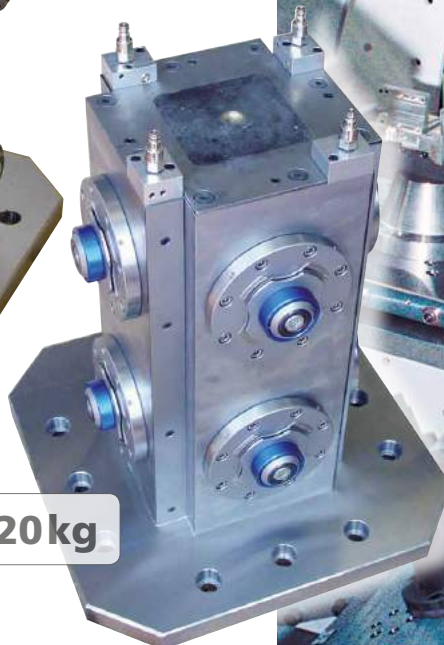

Mehr Informationen siehe Tripoxy Mineral
For more information check the Tripoxy Mineral

p. 272

Nullpunkt-System OPP & Erowa MTS

In Verbindung mit dem Spannsystem Power Clamp bilden die Nullpunkt-Paletten OPP-System sehr kompakte, hochgenaue und schnell wechselbare Spannvorrichtungseinheiten.

Zentrischspanner mit OPP-Anschluss

Das neue mechanische 0-Punktsystem (**OPBM4Q100R50**) findet seine Einsatzmöglichkeiten in allen Bereichen.

Von der einfachen Schnellwechselpalette zur Einzelteilbearbeitung bis hin zur Mehrfachspannung in modernen Fräszentren.

Dank der hohen Wiederholgenauigkeit lassen sich Grossserien problemlos und in höchster Genauigkeit fertigen.

Zero-point system OPP & Erowa MTS

Together the modular system with zero point pallets, give a great performance! Fast changing and accurate!

Self centering vise with integrated zero point adaptation OPP

Because of its compact build body this self centering vise gives a perfect performance to automated 5 axis machines!

The index zero point system is built into the body of the vise, a sub pallet as you normally mount the vises!

The OPP system is a very accurate system reliable and durable! We guarantee 150'000 changes within $\pm 0,002\text{mm}$

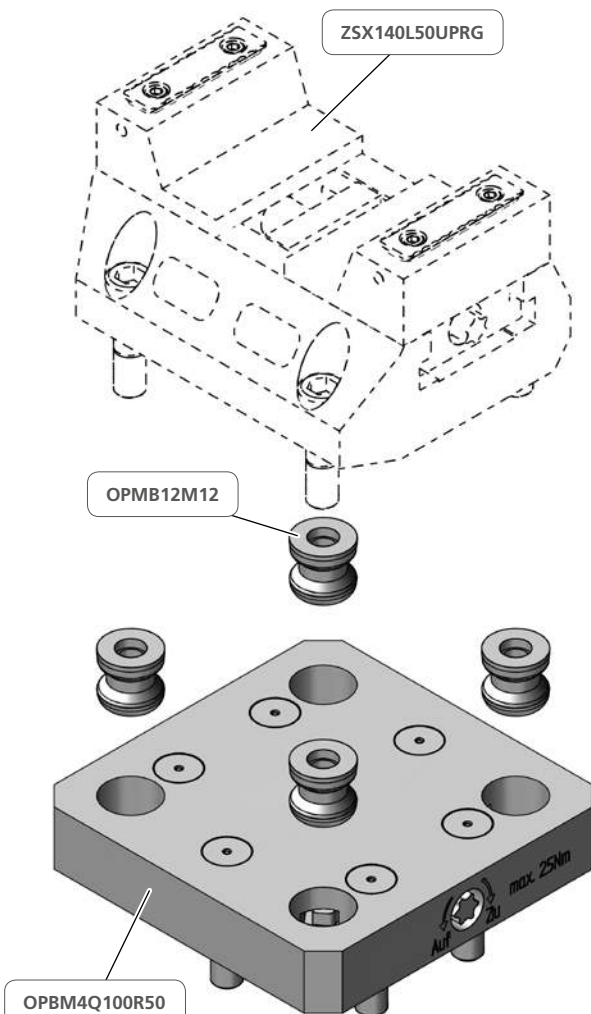

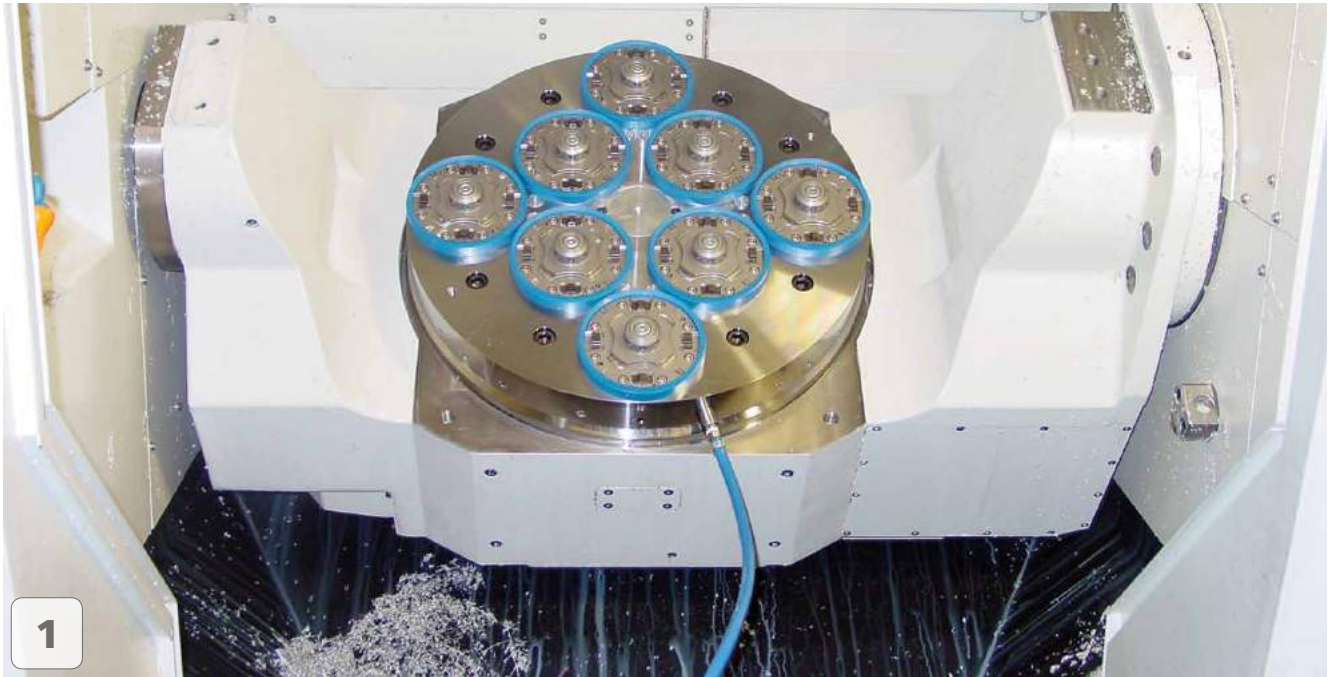

HORIZONTAL





6 PowerCLAMP Basisschiene mit microCLAMP Vorrichtung. Automatisiert mit Erowa Roboter.
PowerCLAMP baserail with microCLAMP. Automated with Erowa Robot.

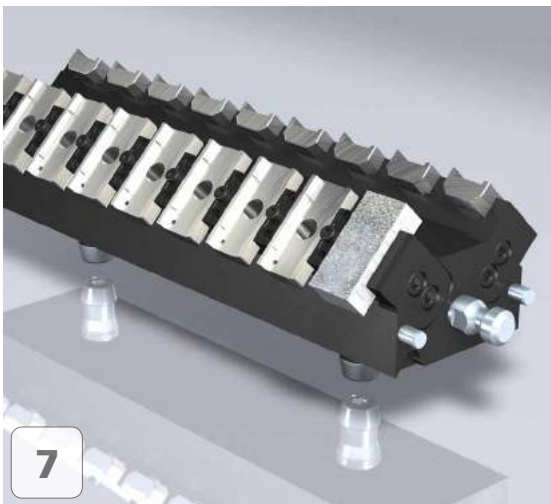

7

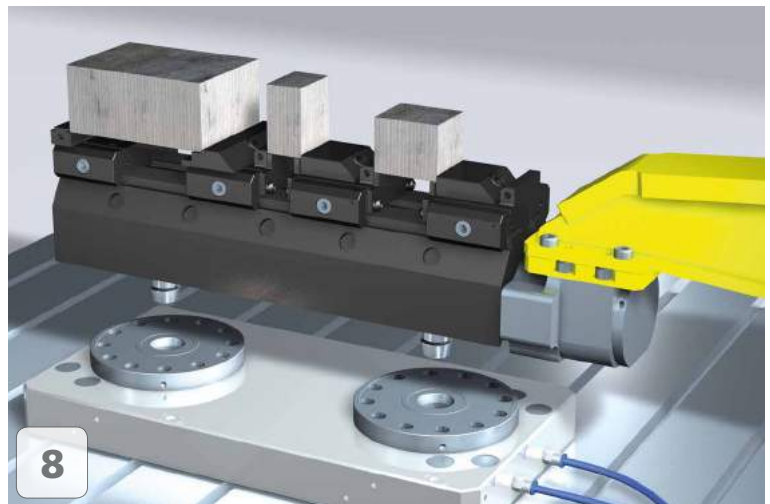

8

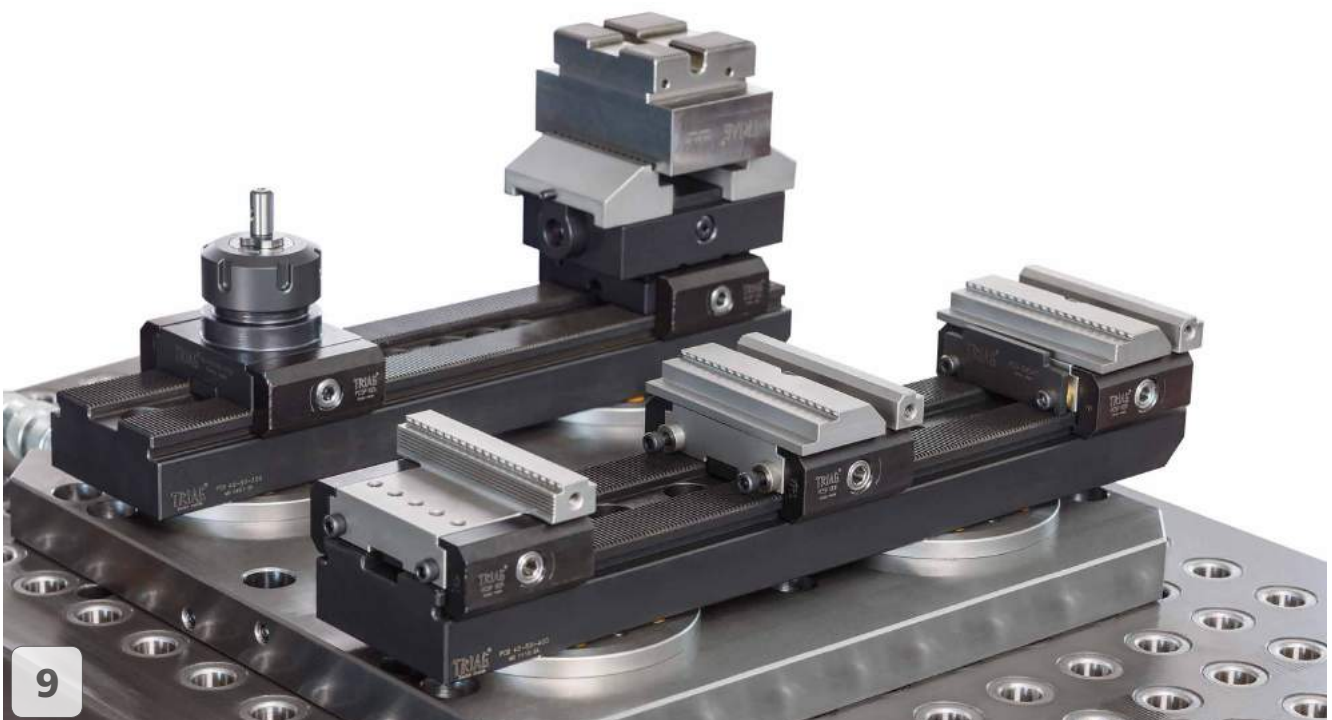

9

Mechanisches Nullpunktsystem mit diversen Spannlösungen

Mechanical zero point system with different workholding solutions



oppSystem

Da die Anforderungen an „just in time“ Produktion in den letzten Jahren stetig gewachsen sind, ist ein modulares Nullpunkt Schnellwechselsystem der richtige Weg um lange Standzeiten der Werkzeugmaschine zu verhindern.

Since the requirements for „just in time“ production have grown steadily in the recent years, a modular zero-point quick-change system is the right way to prevent long down time of a machine tool.

- ✓ **Sehr tiefe Bauhöhe (28 mm)**
- ✓ **Wiederholgenauigkeit 0.01 mm**
- ✓ **6000 dAN Haltekraft**
- ✓ **Abhebefunktion ein- und ausschaltbar (3-4 mm)**

- ✓ **Very low height (28mm)**
- ✓ **Repeat accuracy of 0.01mm**
- ✓ **6000daN holding force**
- ✓ **Lift-off function can be switched on and off (3-4mm)**

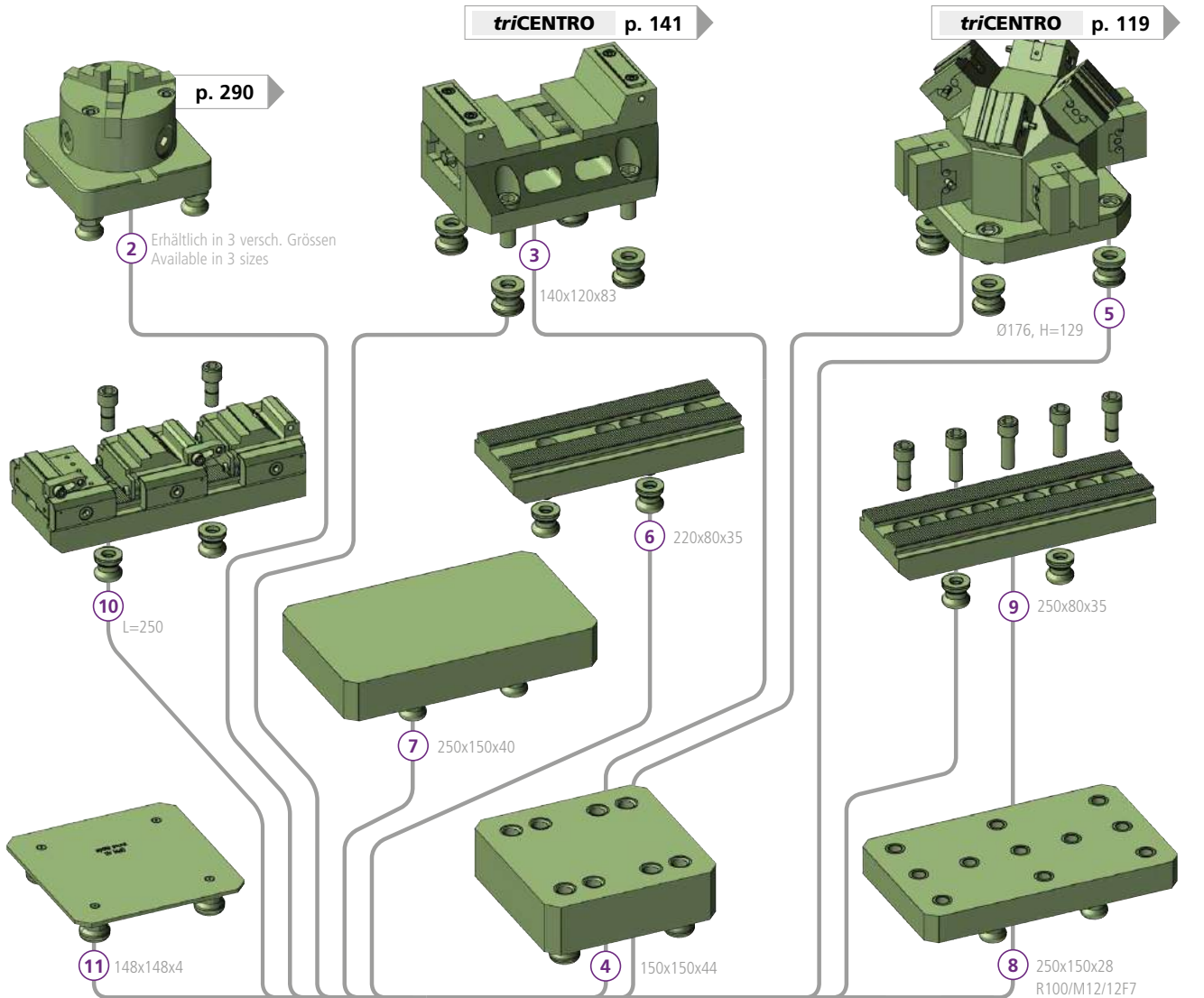

150x150x28 **A p. 287**



235x235x25 **B p. 287**

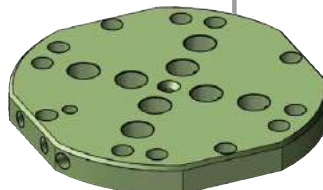

A	0-Punkt Basis / 0-point Base	kg
	OPBM4Q100R50	~3,8
	TB160379	~7,6
B	3-Backenfutter / 3-jaw chuck	kg
	OPM3X80L75	~5,8
2	OPM3X100L82	~7,3
	OPM3X125L88	~9,5

	Zentrischspanner / Self centering vise	kg
3	ZSX140L50UPRG-OPM	~7,1
	Erhöhung / raiser block	kg
4	OPUB150H44	~8,5
	Sputnik I	kg
5	UB5AXMCZ40-45-R100	~5,0

	PC Schiene, -baserail diagonal	kg
6	PCSET18220W2-OPM	~8,2
	Aluminiumplatte -plate	kg
7	OPM25-15RH40	~4,3
	Rasterplatte/ Grid plate	kg
8	OPM25-15R50H28	~7,7
	PC Schiene / PC Rail 250mm	kg
9	PCB2550250-OPM	~4,8
	PowerCLAMP Set	kg
10	PCSET18250-OPM	
	1x PCSET18-250A03	~5,9
	2x PCSET18-L1B48-20	~2,6
	Abdeckung / cover	kg
11	OPM-AD	~0,8

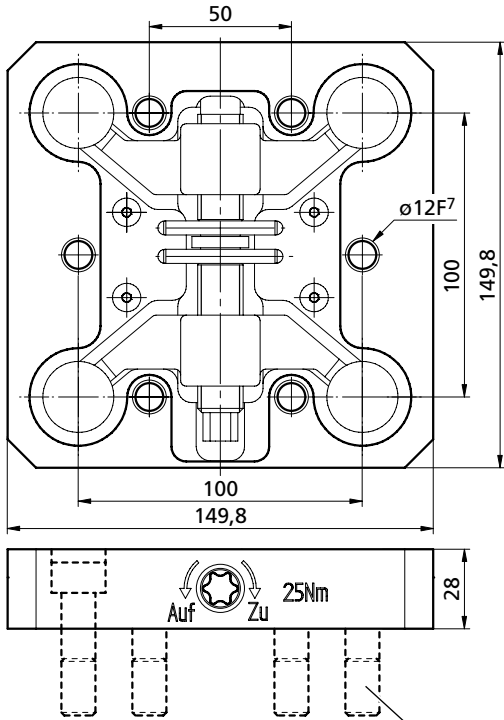

* Optional erhältlich
Optional accessory

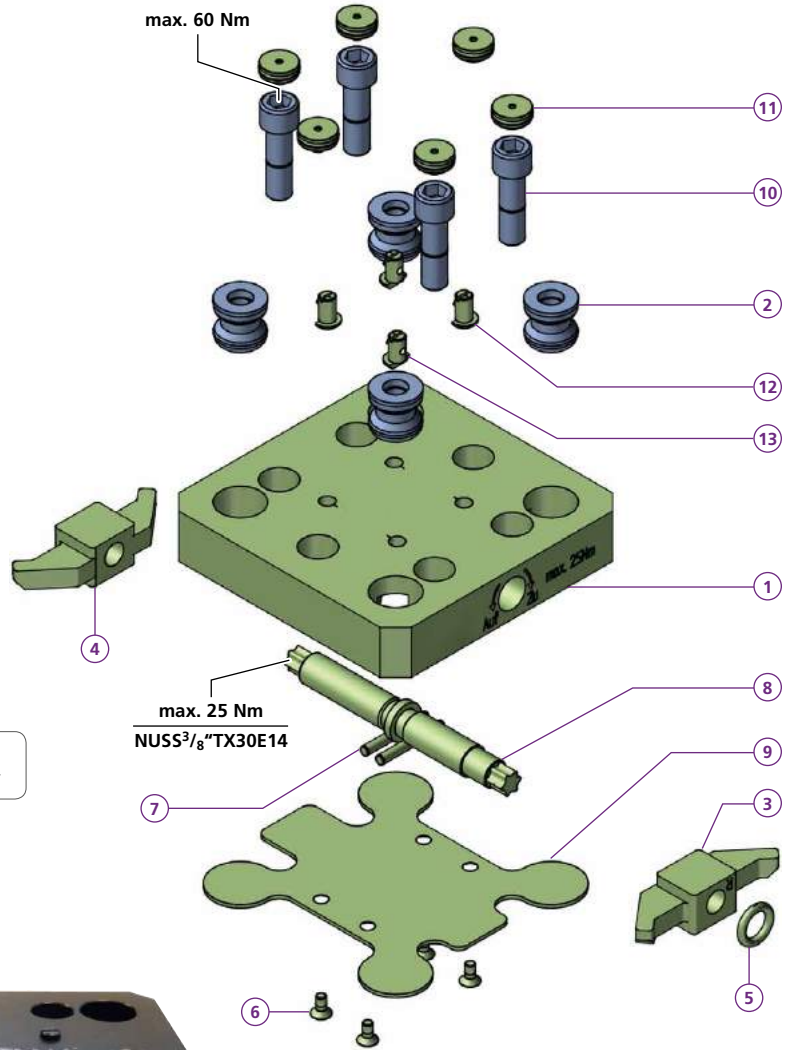

OPBM4Q100R50	
1	1x TB150065
2	4x OPMB12M12
3	1x TB150068
4	1x TB150069
5	1x OR 14x4
6	4x M5x10 DIN7991
7	2x 5m6x40 DIN 6325
8	1x TB150066
9	1x TB150067
10	4x TWPAS1240
11	6x PCPF16L6
12	4x TB150657
13	1x TN100254
kg	~3,8

p. 289



WICHTIG!
Bitte separat bestellen

IMPORTANT!
Please order separately

NUSS3/8"TX30E14

Bestellbeispiel / Ordering example:

1x OPBM4Q100R50 & 4x OPMB12M12 4x TWPAS1240 & 1x NUSS3/8"TX30E14

Universal Flansch
Universal flange

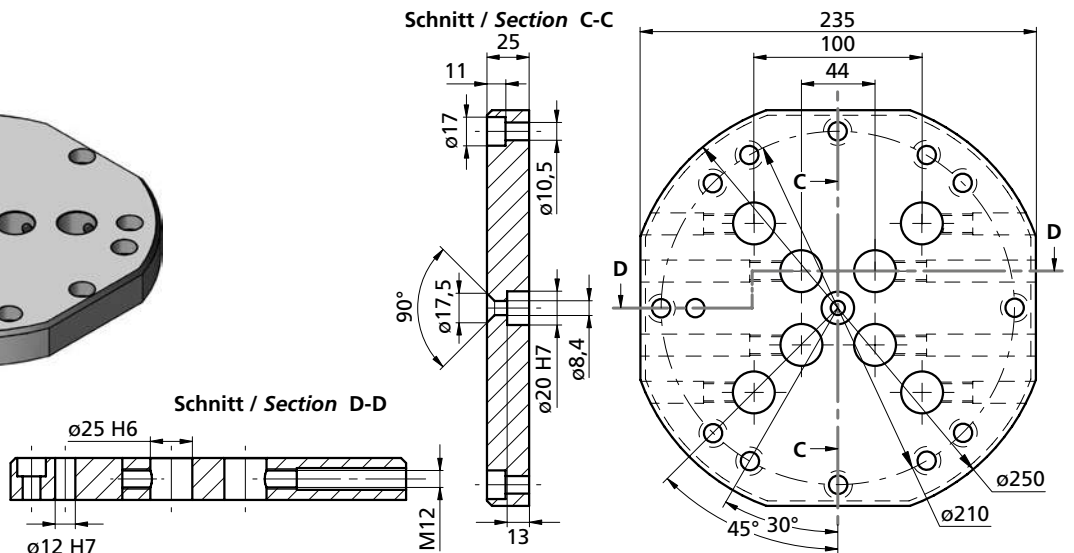
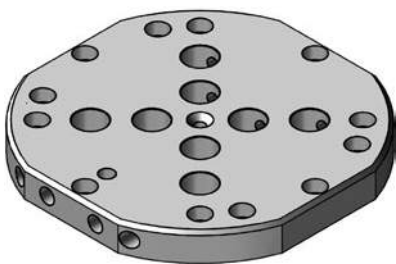

TB160379
kg ~7,6

Separat bestellen / Separate order

0-Punkt Erhöhung

Zero point riser

OPUB150H44



oppSystem

Optimal kombinierbar mit der Erhöhung (**OPUB150H44**) für eine bessere Zugänglichkeit zum Werkstück.

Ideally combined with the riser (**OPUB150H44**) for better access to work piece.

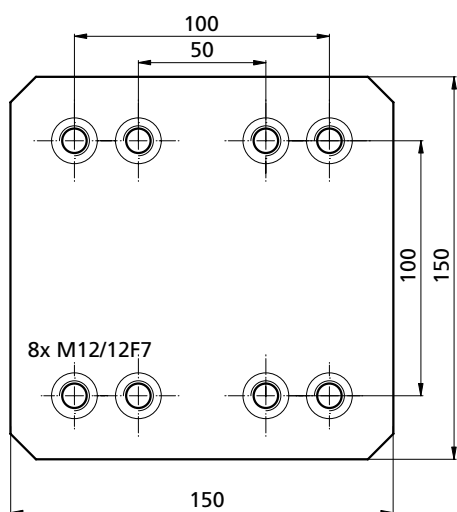
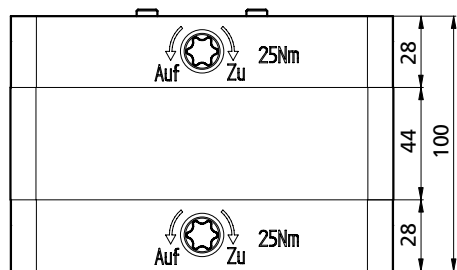

Anwendungsbeispiel mit Zentrischspanner
Application example with self centring vise

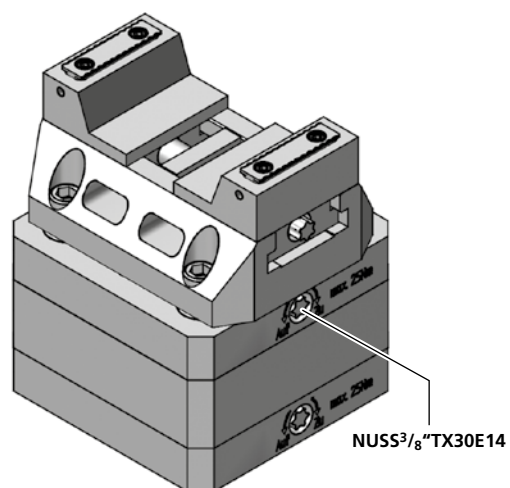
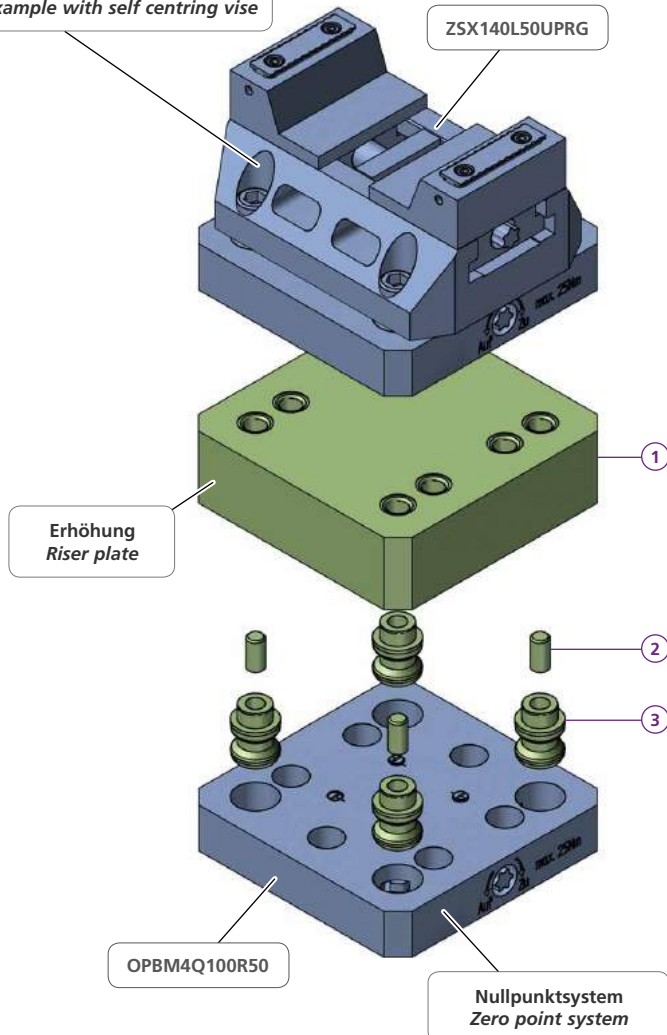

OPUB150H44	
1	1x TB150756
2	4x TN1000067
3	4x OPBM18M12
kg	~8,5

WICHTIG!
Bitte separat bestellen

IMPORTANT!
Please order separately

NUSS3/8"TX30E14

Bestellbeispiel / Ordering example: 1 x **OPUB150H44** & 2 x **OPBM4Q100R50** & 1 x **ZSX140L50UPRG** & 1 x **NUSS3/8"TX30E14**

Separat bestellen / Separate order

Ausrichtplatte Alignment plate OPMAW



oppSystem

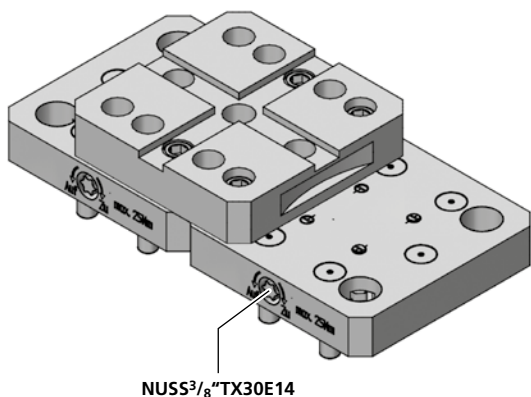
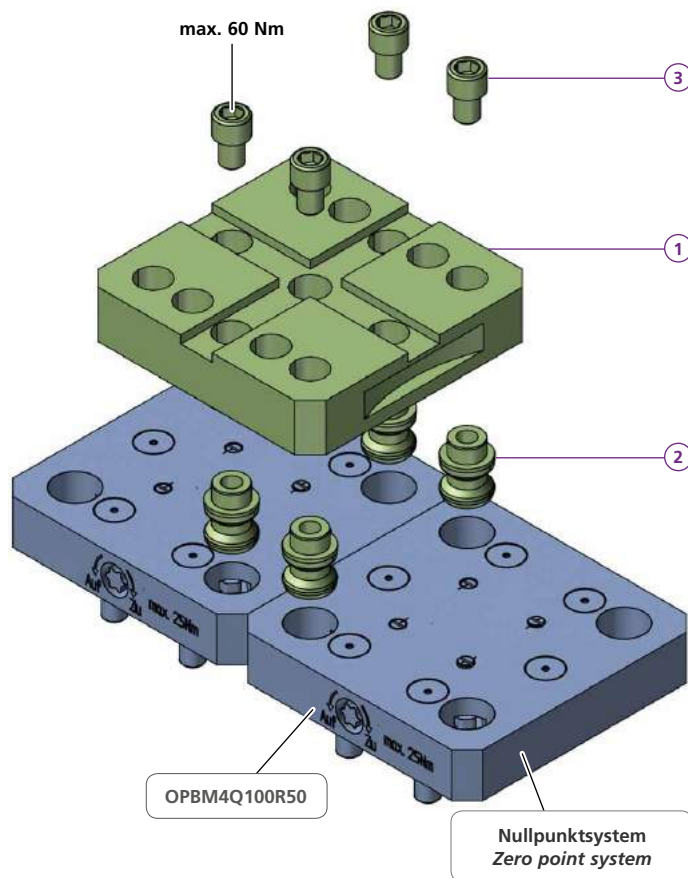
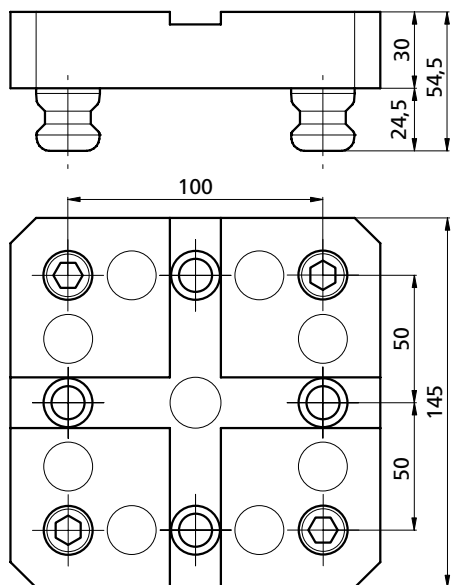

- OPMAW**
- ① 1x TB151141
 - ② 4x OPMB18M12
 - ③ 4x M12x16 DIN912
- kg ~3,54

WICHTIG!
Bitte separat bestellen

IMPORTANT!
Please order separately

NUSS3/8"TX30E14

Nullpunkt Zentrier- und Klemmbolzen Zero point pull studs	Nullpunkt Schwertbolzen Diamond pull studs	Klemmbolzen mit Untermass Pull studs with minus tolerance	Schutzbolzen Protection bolts
 OPMB18M12 kg ~0,1	 OPMB18M12S kg ~0,1	 OPMB18M12U kg ~0,1	 OPMBL kg ~0,08
 OPMB12M12 kg ~0,06	 OPMB12M12S kg ~0,06	 OPMB12M12U kg ~0,06	 kg ~0,06

Bestellbeispiel / Ordering example : 1x TB160379

Separat bestellen / Separate order

Dreibackfutter Three-jaw chuck

OPM3X80L75
OPM3X100L82
OPM3X125L88



oppSystem

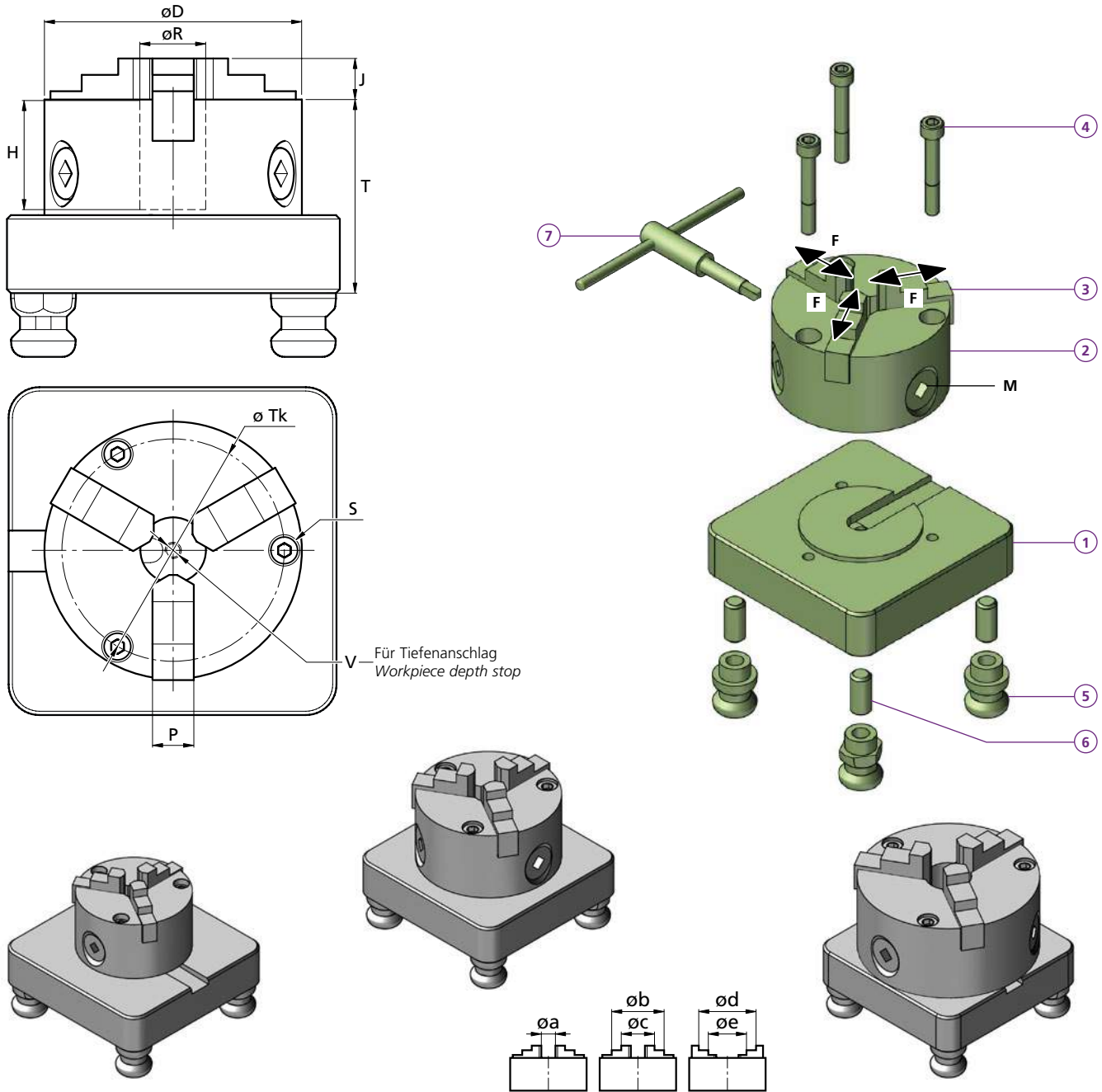

	D	J	T	R	H	P	V	a mm	b mm	c mm	d mm	e mm	max. M	max. F	ØTk	S
OPM3X80L75	80	13	75	15	42,5	10	M6	3...27	48...73	23...48	52...76	27...51	28 Nm	1300 daN	67	M6
OPM3X100L82	100	17	82	20	49,5	14	M8	3...39	58...94	24...60	64...100	30...66	38 Nm	1600 daN	83	M8
OPM3X125L88	125	19	88	32	55	16	M8	3...49	70...116	30...75	83...125	38...84	55 Nm	2600 daN	108	M8

OPM3X80L75	OPM3X100L82	OPM3X125L88
1 1x TB161207A	1 1x TB161208A	1 1x TB161209A
2 1x 243809.0083220	2 1x 243809.0103220	2 1x 243809.0123220
3 2x 3 Stk. / pcs	3 2x 3 Stk. / pcs	3 2x 3 Stk. / pcs
4 3x TN100346	4 3x TN100360	4 3x TN100361
5 2x OPMB18M12	5 2x OPMB18M12	5 2x OPMB18M12
2x OPMB18M12U	2x OPMB18M12U	2x OPMB18M12U
6 4x TN100067	6 4x TN100067	6 4x TN100067
7 1x 243864.0080000	7 1x 243864.0100000	7 1x 243864.0120000
kg ~ 5,8	kg ~ 7,3	kg ~ 9,5

243849.0083200 243850.0083200

243849.0103200 243850.0103200

243849.0123200 243850.0123200

3x
Ø 3 - 49 3x
Ø 38 - 125

*243834.0083300

*243834.0103300

*243834.0123300

3x
*Weich
Soft
16MnCr5

Separat bestellen / Separate order

Bestellbeispiel / Ordering example: **OPM3X80L75**

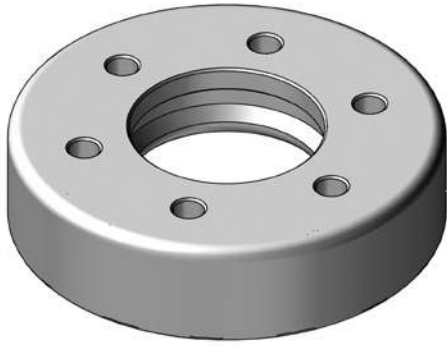

OP92BUE23

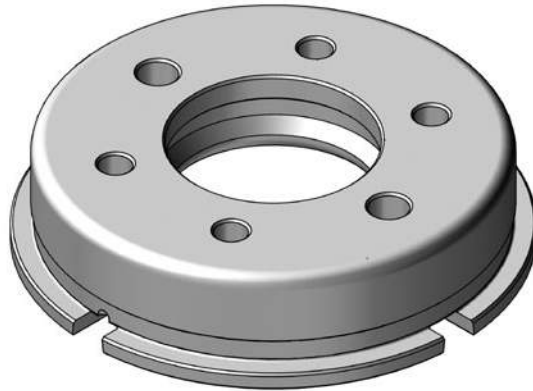

OP92BUE23ID

	kg
OP92BUE23	~0,75
OP92BUE23ID	~0,78

Bestellbeispiel / Ordering example: **OP92BUE23**

Einbauanleitung / Assembling instructions

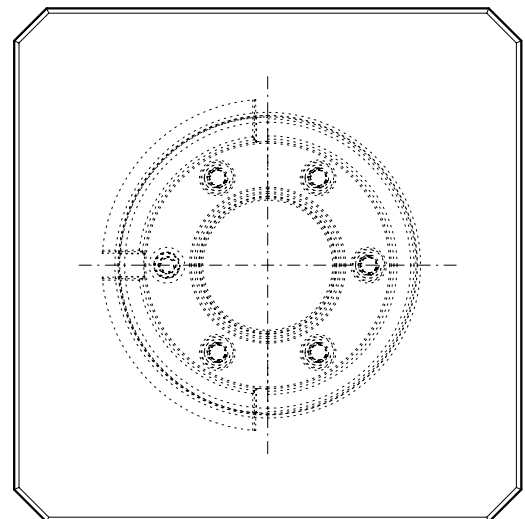
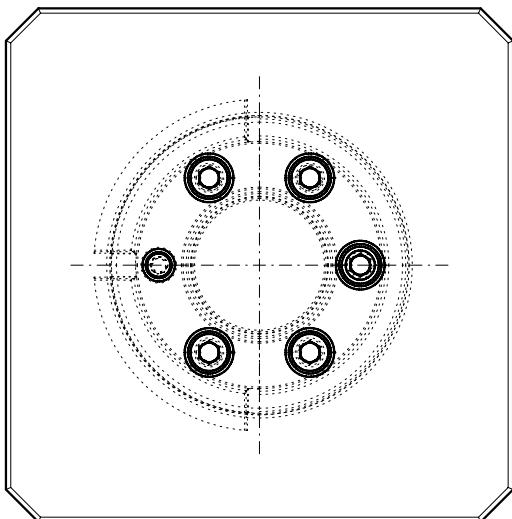
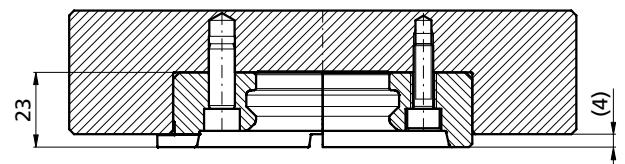
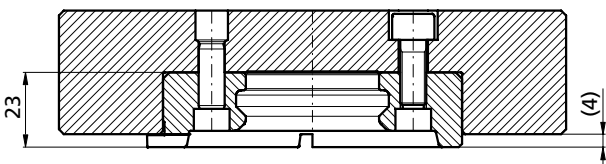
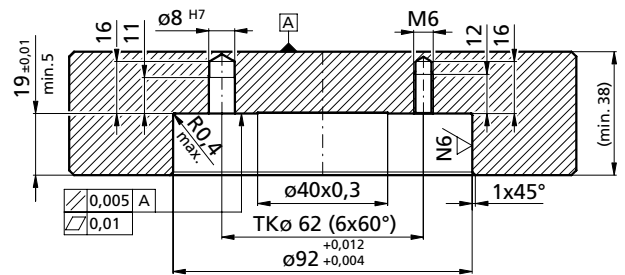
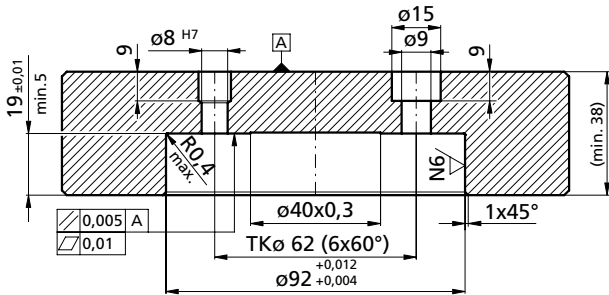

Zentriereinheit
Chuck unit

Zentrierkörper
Chuck body



oppSystem

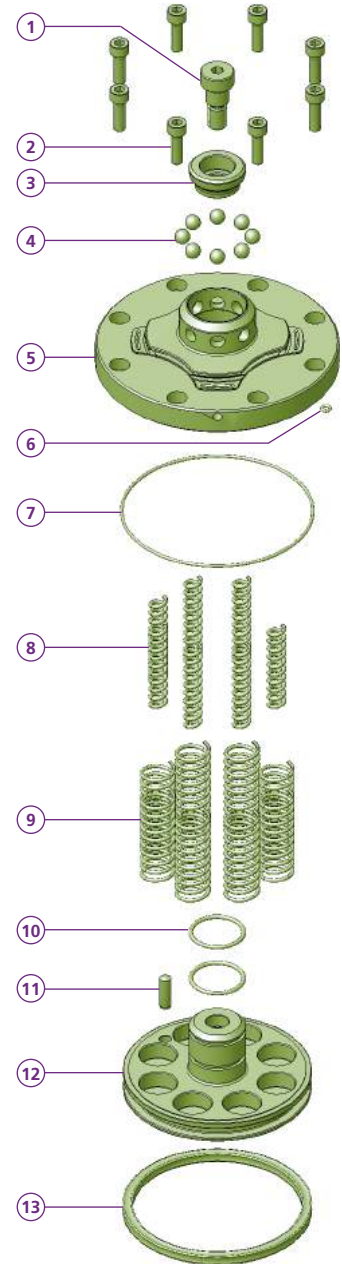
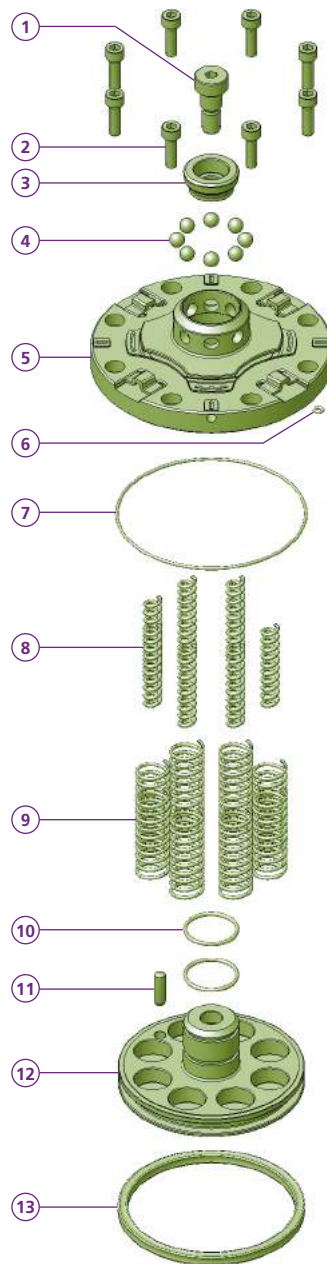
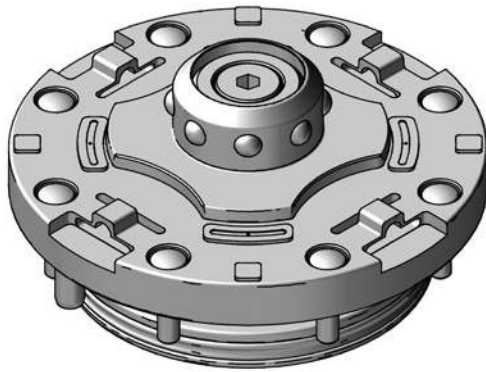

OPEGBID (Index)

- ① 1x OPPAS M10x12
- ② 8x M6 x 20 ST
- ③ 1x OPKN 30x13,5
- ④ 8x RB - 8/G20W
- ⑤ 1x **OPEBID**
- ⑥ 1x OR 3x1,5
- ⑦ 1x OR 90x1,5
- ⑧ 8x FED1044
- ⑨ 8x FED2051
- ⑩ 2x OR 26x2
- ⑪ 1x 6m6x20 DIN 6325
- ⑫ 1x OPKLB100
- ⑬ 1x OPDR885

kg ~2,28

OPEGB

- ① 1x OPPAS M10x12
- ② 8x M6 x 20 ST
- ③ 1x OPKN 30x13,5
- ④ 8x RB - 8/G20W
- ⑤ 1x **OPEB**
- ⑥ 1x OR 3x1,5
- ⑦ 1x OR 90x1,5
- ⑧ 8x FED1044
- ⑨ 8x FED2051
- ⑩ 2x OR 26x2
- ⑪ 1x 6m6x20 DIN 6325
- ⑫ 1x OPKLB100
- ⑬ 1x OPDR885

kg ~2,26

Bestellbeispiel

Ordering example: OPEGBID

1er Palettenträger Receiver chuck with 1 chucks



oppSystem

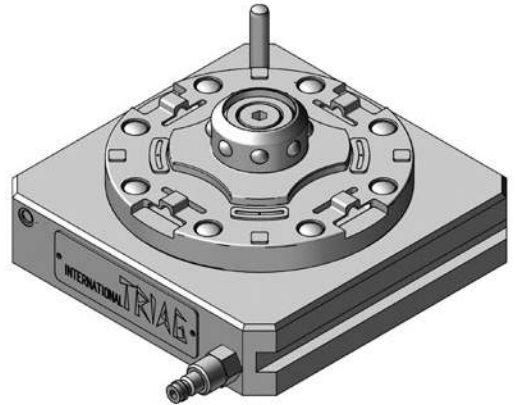
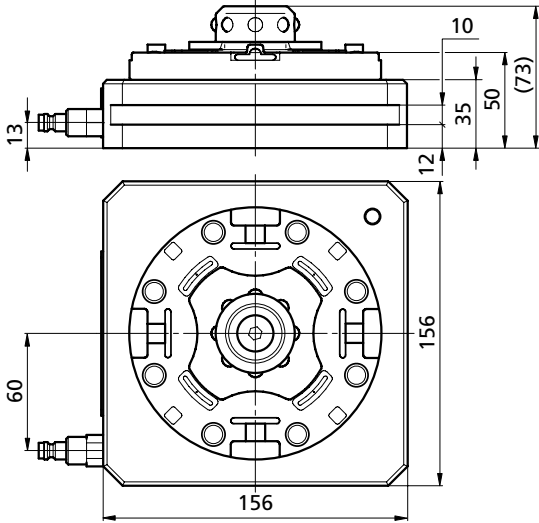

Bestellbeispiel / Ordering example : **OPB1ID**

	kg
OPB1ID (Index)	~8,0

1er Palette Pallet with 1 clamping case

Bestellbeispiel / Ordering example: **OPA1ID160**

	H	P	kg
OPA1ID160	60,2	56,2	~3,95
OPA1ID200	60,2	56,2	~6,06
OPA1ID160R50	60	56	~4,04
OPA1ID200R50	60	56	~6,12
OPA182H63-RS	= weicher Stahl / soft steel		~11,03

Basis mit integrierter 0-Punkt Index Aufnahme oppSystem Base rail with integrated oppSystem index

Bestellbeispiel / Ordering example: **OPA1IDPCB178**

	kg
OPA1IDPCBD178	~7,0

2er Palettenträger Receiver chuck with 2 chucks



oppSystem

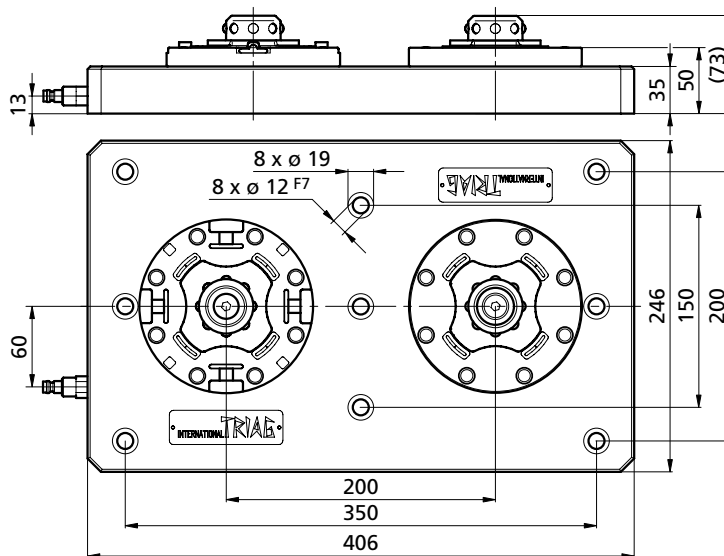
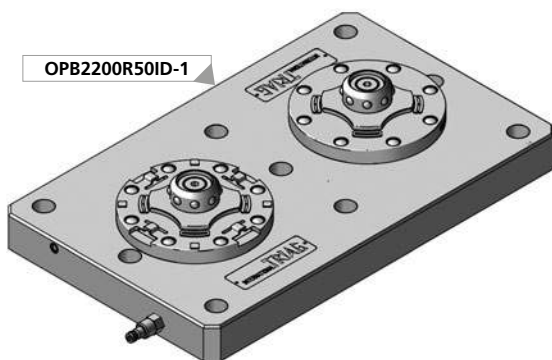
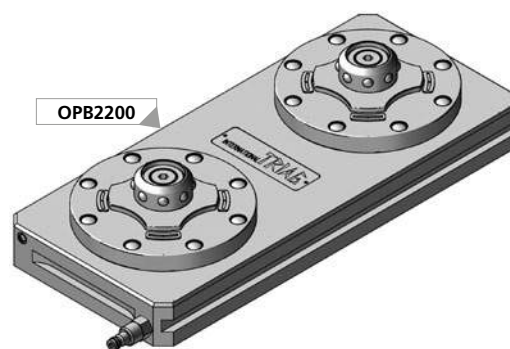
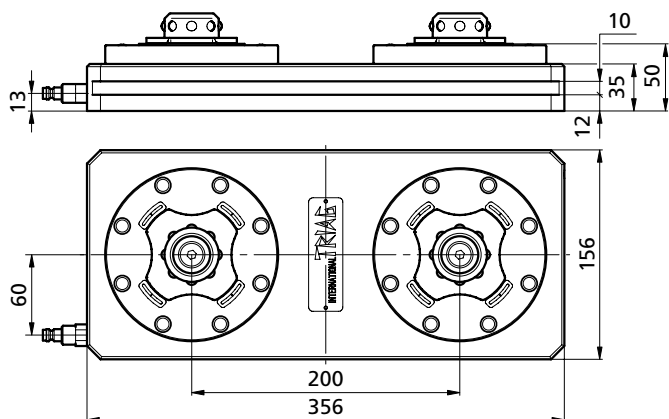

	kg
OPB2200	~17,50
OPB2200R50	~30,00
OPB2200R50ID-1 (Index)	~30,00
OPB2200R50ID-2 (Index)	~30,00

Bestellbeispiel / Ordering example: **OPB2160**

2er Palette Pallet with 2 clamping case

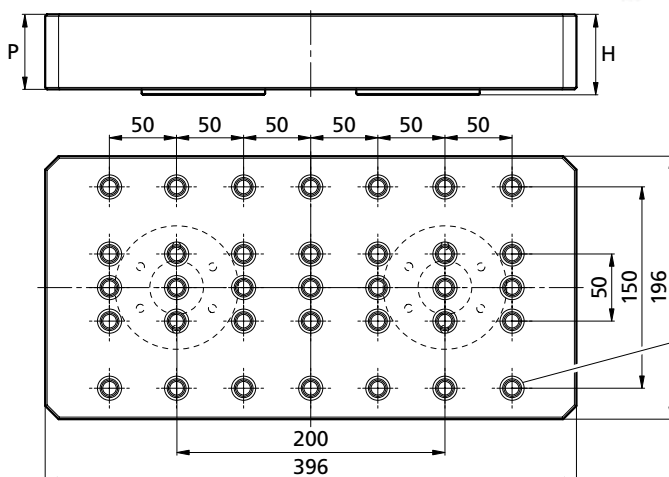
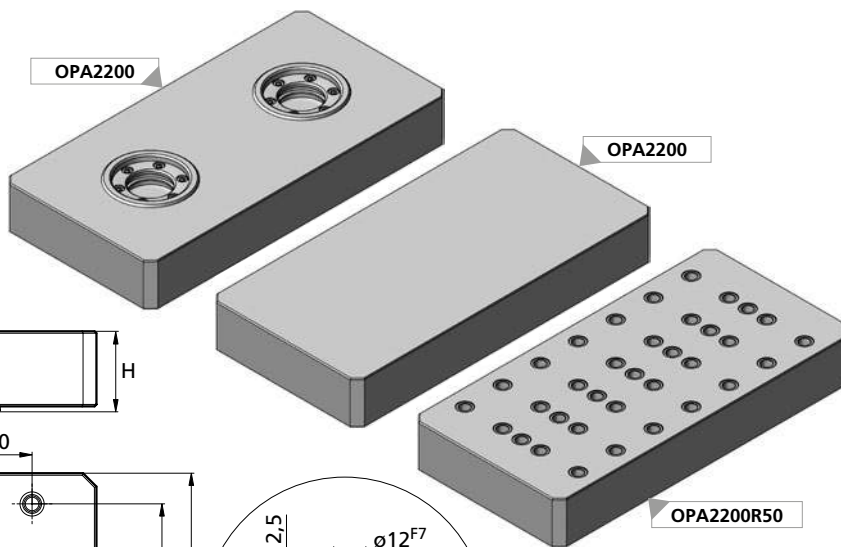

	H	P	kg
OPA2200	60,2	56,2	~12,18
OPA2200R50	60	56	~12,32

Bestellbeispiel / Ordering example: **OPA2200R50**

3er Palettenträger Receiver chuck with 3 chucks



oppSystem

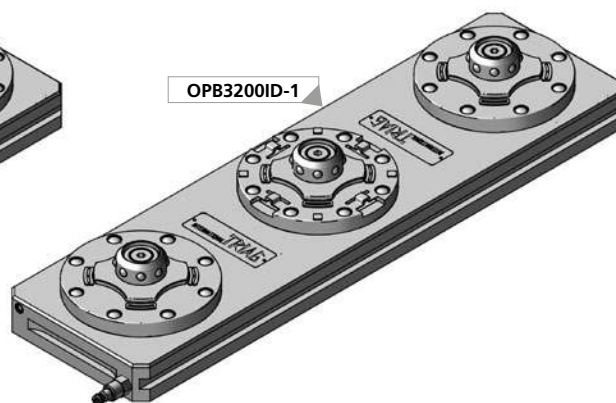
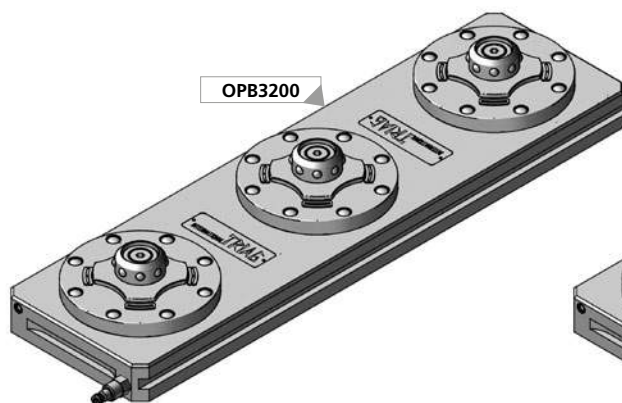
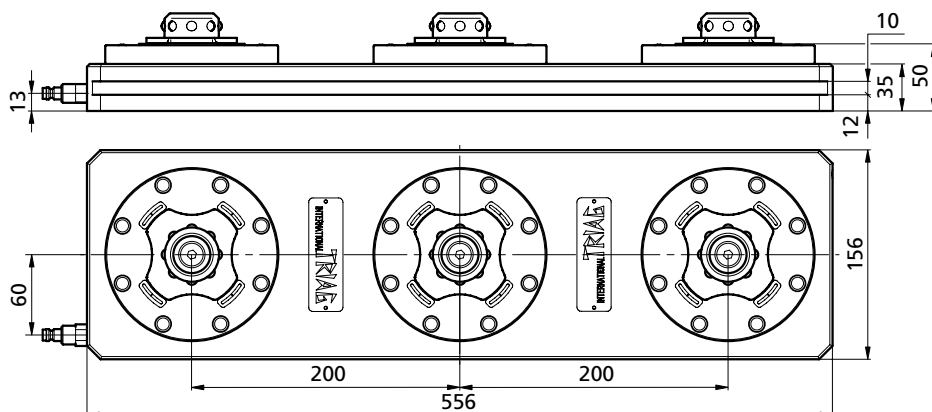

	kg
OPB3200	~27,00
OPB3200ID-1 (Index)	~27,00

Bestellbeispiel / Ordering example: **OPB3200**

3er Palette Pallet with 3 clamping case

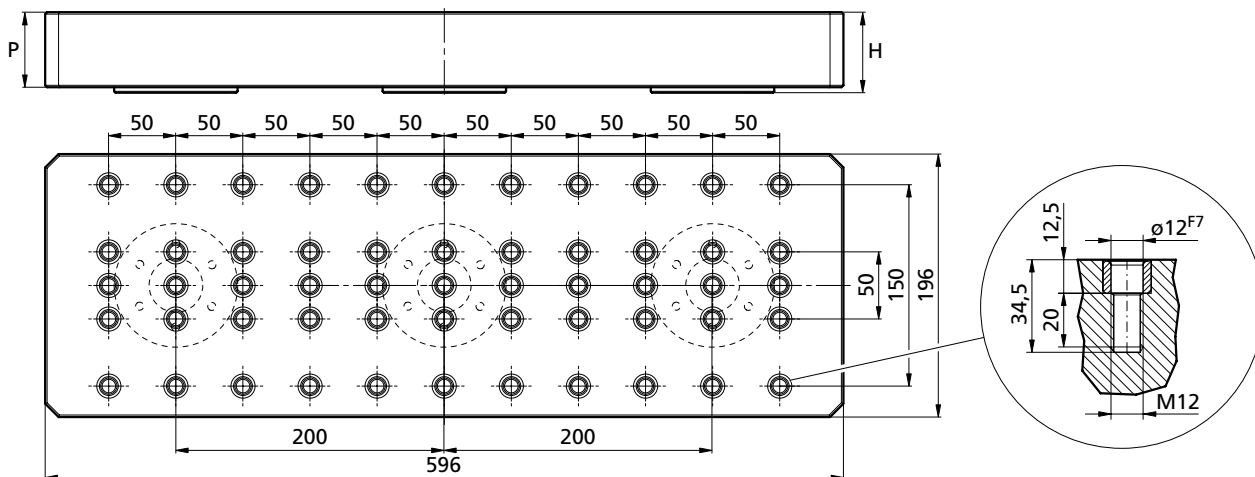
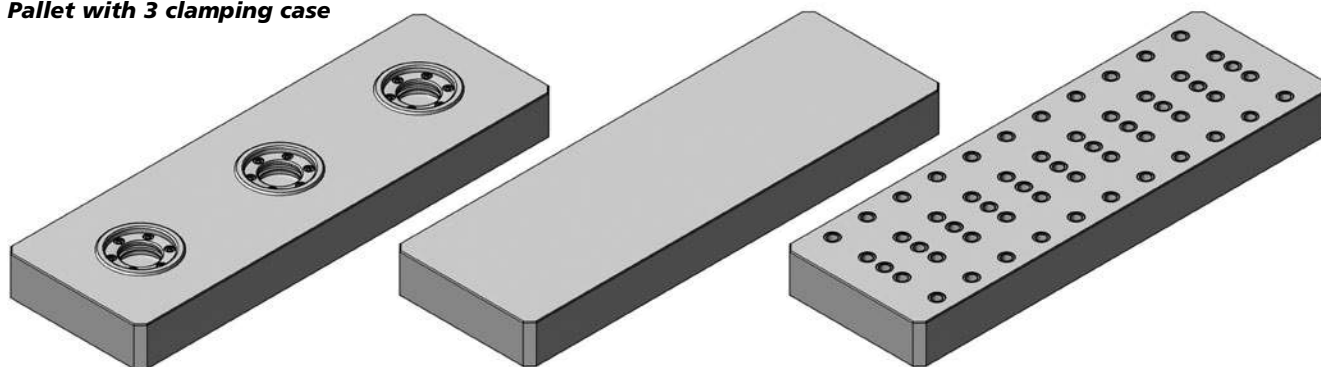

	H	P	kg
OPA3200	60,2	56,2	~18,36
OPA3200R50	60	56	~18,57

Bestellbeispiel / Ordering example: **OPA3200**

4er Palettenträger Receiver chuck with 4 chucks



oppSystem

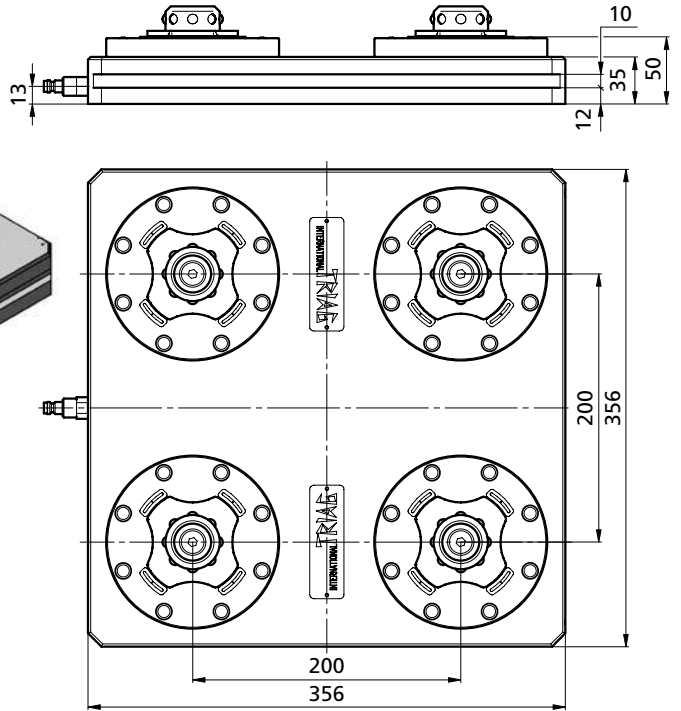

		kg
OPB4Q200		~39,00

Bestellbeispiel / Ordering example: **OPB4Q200**

4er Palette Pallet with 4 clamping case

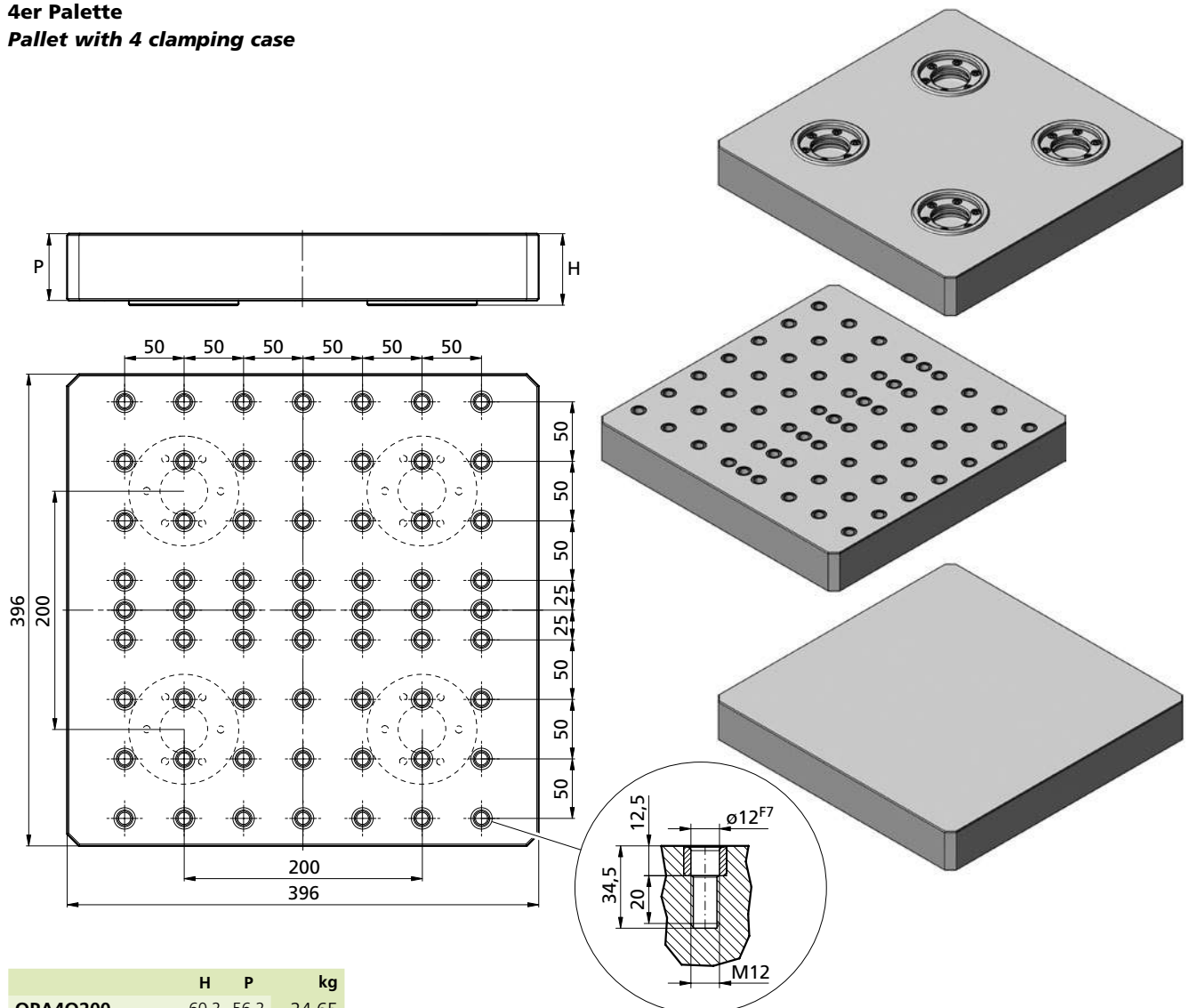

	H	P	kg
OPA4Q200	60,2	56,2	~24,65
OPA4Q200R50	60	56	~24,88

Bestellbeispiel / Ordering example: **OPA4Q200**

EROWA MTS Einbauspannfutter / Integral chucks

Einbauvariante (gültig für MTS IntegralChuck Single und Multi). Toleranzen entsprechend der Einbauanleitung beachten!

Integration variant (applicable to MTS IntegralChucks Single and Multi). Observe tolerances according to integration instructions!

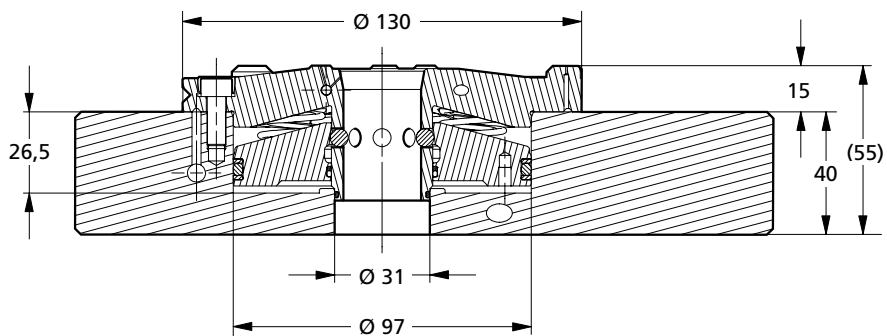

Manuelle Bedienung
Manual operation



Geeignet zur Anwendung unter Flüssigkeit
Suited for submerged operation



Geeignet für automatische Anwendung
Suited for automatic operation



Mit Druckluftpistole bedienen
Operate with compressed air jet



Für spanabhebende Bearbeitung
For chip-removing processes



Zum Senkerodieren
For EDM sinking

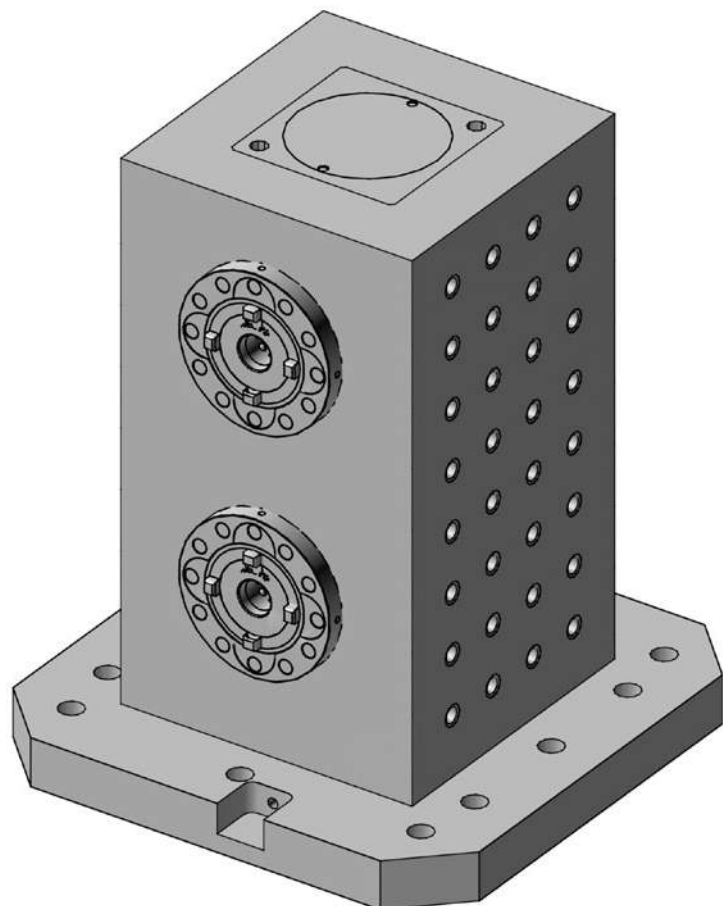

1 Präzise

Spielfreie Kurzkegel-Zentrierung.
 Repetiergenauigkeit: < 0,005 mm.
 Leichtes Einfahren der Paletten.

1 Precise

Play-free round-cone centering.
 Repeatability: <0.005 mm.
 Easy insertion of the pallets.

2 Spannmechanismus

Zuverlässiger Spannmechanismus durch selbsthemmenden Kugelverschluss.

2 Clamping mechanism

Reliable clamping mechanism through self-locking ball lock.

3 Öffnen

MTS Spannfutter werden pneumatisch betätigt.

3 Open

MTS are operated pneumatically.

4 Sauberkeit

Flüssigkeit kann ablaufen, keine Schmutzecken.

4 Cleanliness

Liquids can drain off. No dirt traps.

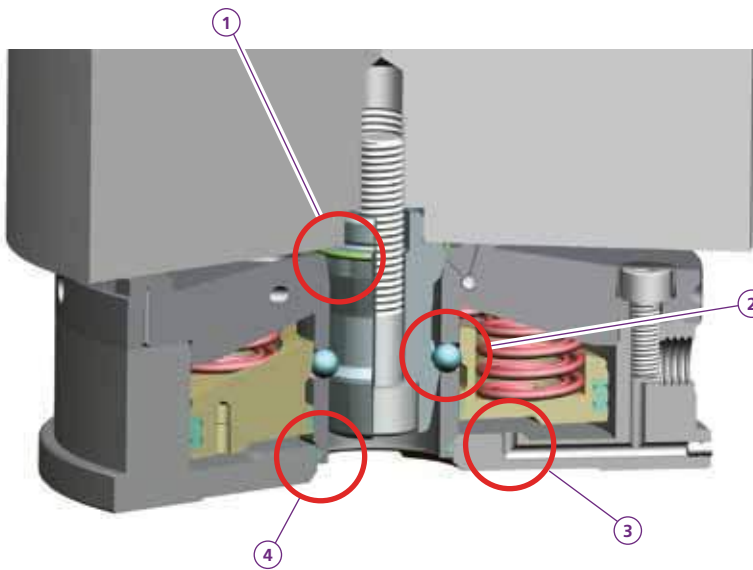

L x B x H: Maschinenabhängig
L x W x H: Depending on the machine

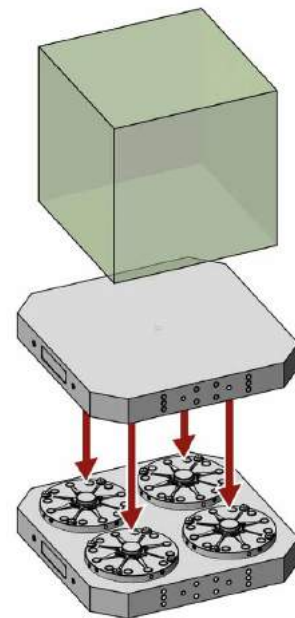

MTS Spannfutter

Das pneumatische MTS Spannfutter benötigt trotz der hohen Spannkraft von 12'000 N dank interner Kraftverstärkung nur 7 bar Öffnungsdruck.

MTS Spannfutter, automatisierbar

Automatische Reinigung der Auflageflächen und des Zentrierzapfens beim Werkstückwechsel.

MTS Chuck

A mere 7 bar of opening pressure results in 12,000 N clamping power thanks to internal power boosting.

MTS chuck, automatable

Automatic cleaning of contact surfaces and of the centering spigot cone while the workpiece is changed.

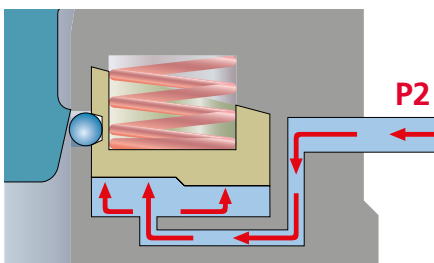

Anschluss P2:
 Öffnen
Prise P2:
 Ouverture

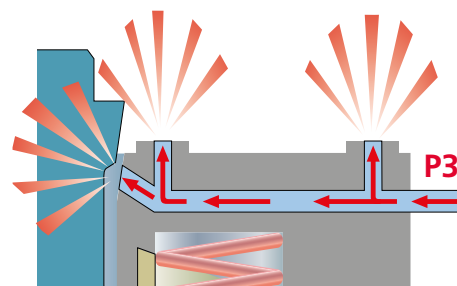

Anschluss P3:
 Reinigen
Prise P3:
 Cleaning

MTS IntegralChuck S-P (single + multiple /manually)

ER-033402



Ausführung Für den direkten Einbau in Maschinentische, Platten, Spanntürme, Winkel oder Teilapparate.

Anschlüsse Zum Öffnen: Pneumatisch.

Anwendung Zur Aufnahme von Einzel- oder Mehrfachpaletten.

Version For direct integration in machine tables, plates, tombstones, squares or dividing heads.

Connections To open: pneumatic or hydraulic.

Application To accommodate single or multiple pallets.

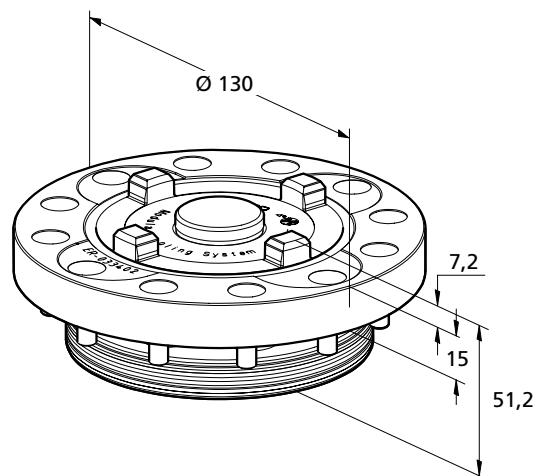

MTS IntegralChuck S-P/A (single + multiple /auto)

ER-036802

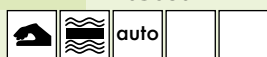

Ausführung Für den direkten Einbau in Maschinentische, Platten, Spanntürme, Winkel oder Teilapparate.

Anschlüsse Zum Öffnen: Pneumatisch.

Zum Reinigen: Pneumatisch.

Anwendung Zur Aufnahme von Einzel- oder Mehrfachpaletten.

Version For direct integration in machine tables, plates, tombstones, squares or dividing heads.

Connections To open: pneumatic.

To clean: pneumatic.

Application To accommodate single or multiple pallets.

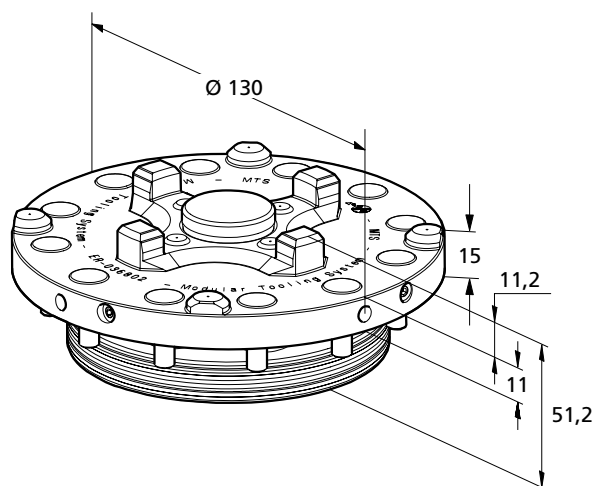

Spannzapfen / Spigot		
ER-033800	manuell / 0-Punkt Zapfen manually zero point locating	
ER-039201	auto / Ausgleichszapfen auto / alignment spigot	
ER-039200	auto / Zapfen mit Spiel auto / spigot with clearance	
ER-038000	auto / 0-Punkt Zapfen auto / Zero point spigot	

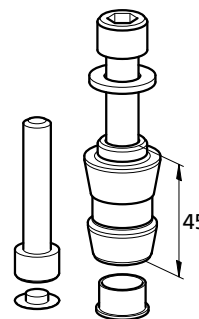

Um Ihnen die schnelle Orientierung über die Anwendungsgebiete der EROWA Produkte zu erleichtern, verwenden wir die folgenden Zeichen:

To make it easier for you to find your way about the fields of application for EROWA products, we use the following symbols:

- S** = Single
- M** = Multi
- A** = Automatisierbar / Able to automate
- P** = Pneumatisch betätigt / Pneumatically operated

MTS IntegralChuck M-P (multiple / manually)

ER-033400



Ausführung Für den direkten Einbau in Maschinentische, Platten, Spanntürme, Winkel oder Teilapparate.

Anschlüsse Zum Öffnen: Pneumatisch.

Anwendung Zur Aufnahme von Einzel- oder Mehrfachpaletten.

Version For direct integration in machine tables, plates, tombstones, squares or dividing heads.

Connections To open: pneumatic or hydraulic.

Application To accommodate single or multiple pallets.

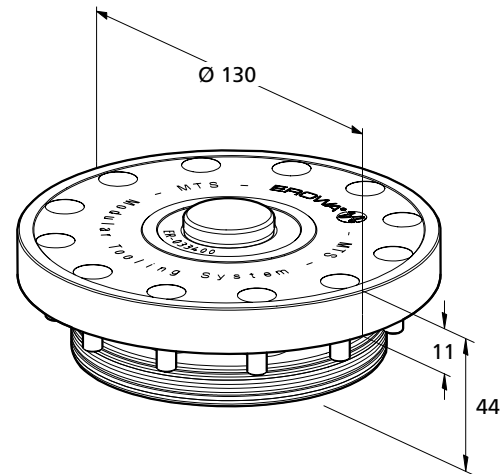

MTS IntegralChuck M-P/A (multiple / auto)

ER-036800

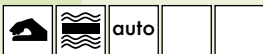

Ausführung Für den direkten Einbau in Maschinentische, Platten, Spanntürme, Winkel oder Teilapparate.

Anschlüsse Zum Öffnen: Pneumatisch.

Zum Reinigen: Pneumatisch.

Anwendung Zur Aufnahme von Einzel- oder Mehrfachpaletten.



Version For direct integration in machine tables, plates, tombstones, squares or dividing heads.

Connections To open: pneumatic.

To clean: pneumatic.

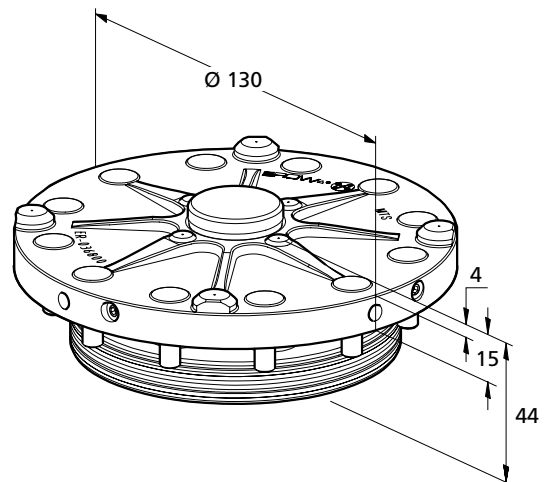
Application To accommodate single or multiple pallets.



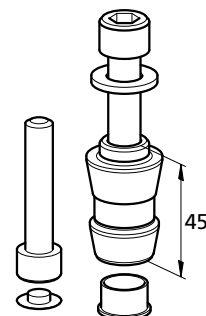

Spannzapfen / Spigot		
ER-033800	manuell / 0-Punkt Zapfen manually zero point locating	
ER-039201	auto / Ausgleichszapfen auto / alignment spigot	
ER-039200	auto / Zapfen mit Spiel auto / spigot with clearance	
ER-038000	auto / 0-Punkt Zapfen auto / Zero point spigot	



Um Ihnen die schnelle Orientierung über die Anwendungsgebiete der EROWA Produkte zu erleichtern, verwenden wir die folgenden Zeichen: *To make it easier for you to find your way about the fields of application for EROWA products, we use the following symbols:*

- S** = Single
- M** = Multi
- A** = Automatisierbar / Able to automate
- P** = Pneumatisch betätigt / Pneumatically operated

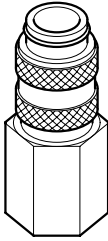
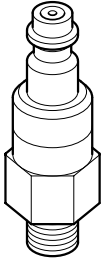

OPSKU	G1/4" Innengewinde <i>Internal thread</i>	OPST-NI	G1/8" Aussengewinde <i>Male thread</i>	OPRV	G1/8" Aussengewinde <i>Male thread</i>
 Schnellkupplung <i>Quick fitting coupling</i>		 Stecknippel verschmutzungsgeschützt <i>Plug nipple protected against staining</i>		 Rückschlagventil <i>Nonreturn valve</i>	
OPANS-8 G1/4" Aussengewinde <i>Male thread</i>					

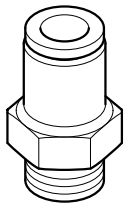

Für 8 mm Schlauch / *For hose*

Abdeckung
Cover

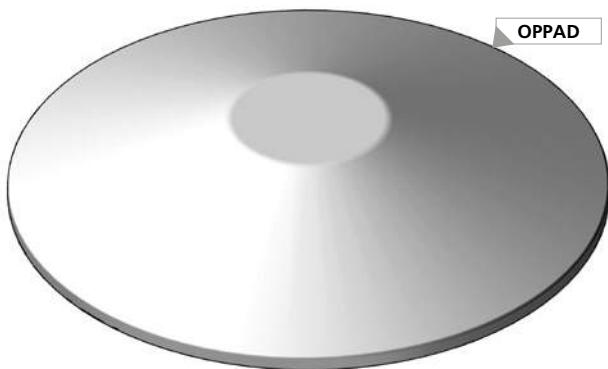

Dichtlippe
Leakproof cover

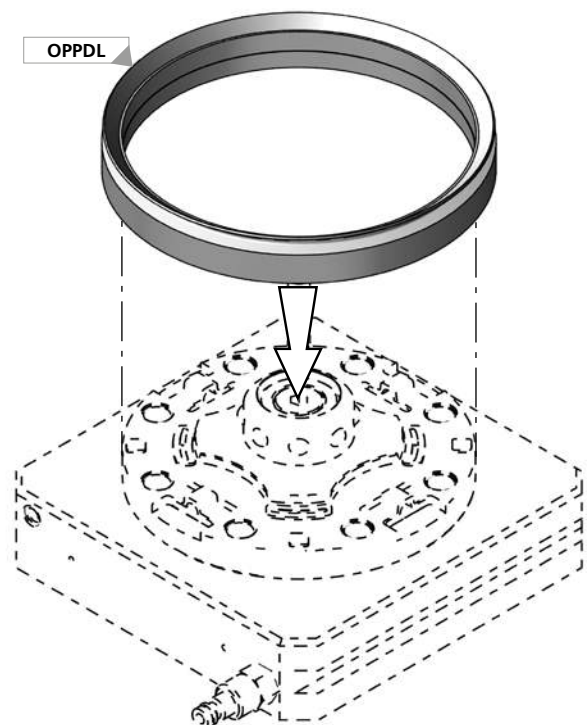

	kg
OPPDL	~0,525
OPPDL	~0,075

Bestellbeispiel / *Ordering example* : 1x **OPPDL**



oppSystem

