



- Quality Is Our Nature
- In Search of Excellence
- LEADWELL Leads the Industry in Taiwan, in the World

**LEADWELL**  
LEADWELL CNC MACHINES MFG., CORP.



**LEADWELL CNC MACHINES MFG., CORP.**



NO.23, Gong 33th Road, Taichung Industrial Park  
Taichung 407, Taiwan  
TEL: 886-4-23591880  
FAX: 886-4-23592555, 23593875  
E-mail: sales@leadwell.com.tw

**www.leadwell.com.tw**

※ All performance are based on 220V/3PH/60HZ. Specification are subject to change without notice.

***T/LTC Series***

**CNC TURNING CENTER**

**T-7i/T-7iM/T-7iS/T-7iSM**

**LTC-20i/LTC-20iM**



## Innovative Design to Outperform Previous Models



- The Ultimate Combination of Power, Versatility & Value in a Linear Way Lathe

TRAVEL	T-7i	T-7iM	T-7iS	T-7iSM
X axis	210+10mm	175+10mm	180+5mm	175+10mm
Z axis	540mm	500mm	480mm	480mm
Chuck Size	8	8	8	8
Bar Capacity	66mm	66mm	66mm	66mm

## SUB-SPINDLE

- The sub-spindle replaces the standard tailstock on turning centers. A position Czi sensor is attached to the sub-spindle so the sub-spindle can then be synchronized with the main spindle. Special software allows the work piece to be transferred from the main spindle to the sub-spindle at any speed for secondary machining operations. This eliminates the need for operator intervention.
- Allow machining on both ends of workpiece.

## LIVE TOOL TURRET

- Each tool can become a rotating tool for both milling and drilling operations.
- Tools can be either radially or axially oriented.

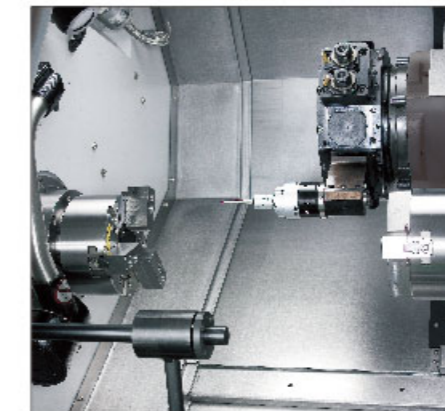
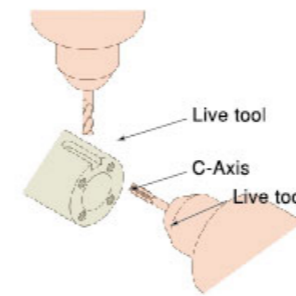

### Power Turret Cutting Capacity:

Tool	12 live tools
Drill	10mm
End Mill	12mm
Tapping	M10xP1.5

TRAVEL	LTC-20i	LTC-20iM
X axis	200+5mm	185+8mm
Z axis	600mm	560mm
Chuck Size	10	10
Bar Capacity	77mm	77mm

## MACHINE ENCLOSURE

- T/LTC series machines are fully enclosed with splash guards and way covers.
- CE approved guarding is also available as an option.

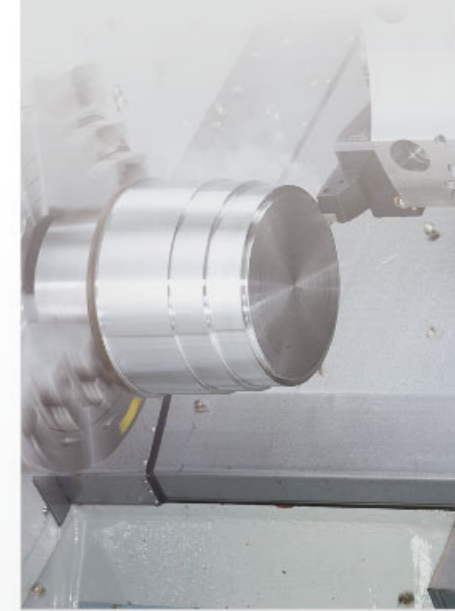
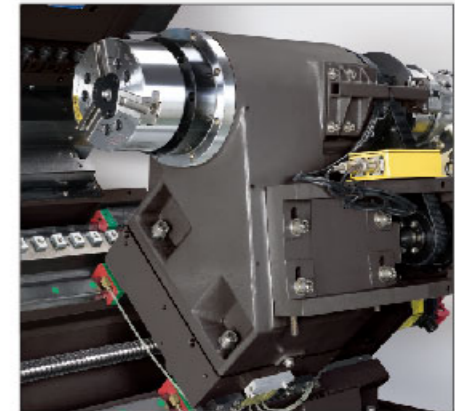
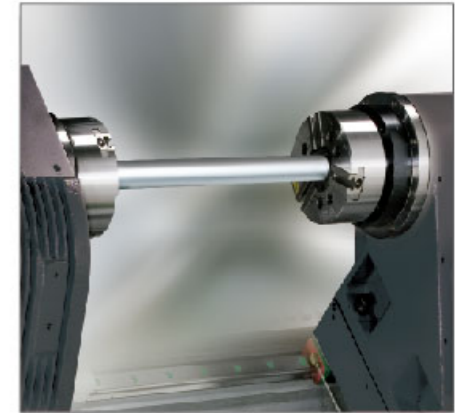



## LEADWELL APPLIES ADVANCED CONCEPTS TO CREATE PERFECTION IN STRUCTURAL DESIGN.

- LEADWELL uses only top quality well-ribbed castings.
- Finite Element Analysis (FEA) is used on each new casting to determine the size and location of all internal ribs ensuring high torsional stiffness and minimum vibration.
- The cast iron base, saddle, headstock, slide and tailstock are ruggedly constructed for superior stability and machining accuracy.

## EXTRA WIDE SPAN FOR INCREASED STABILITY

- The T/LTC series utilizes oversized box ways for high horse power machining. The extremely rigid body base frame with box ways provides outstanding stability for precision turning.

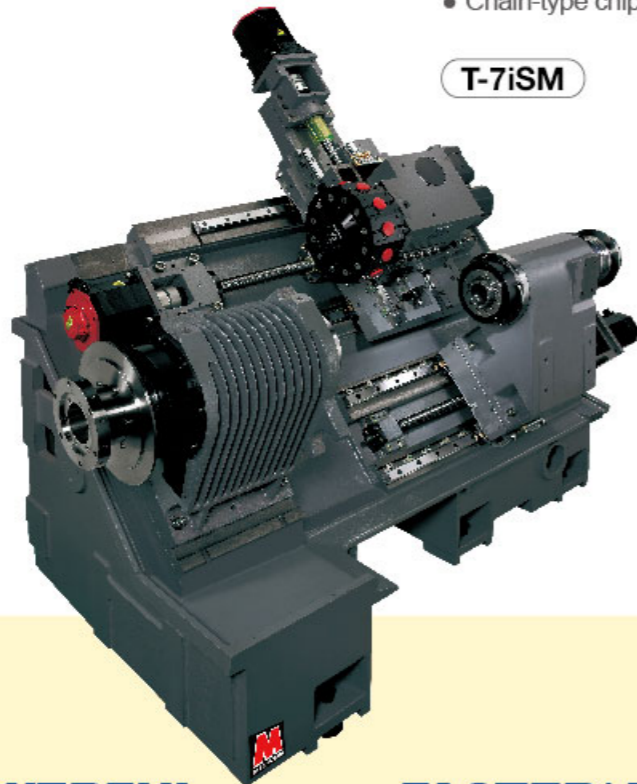

T-7iSM

## 45° MASSIVE SLANT BED

### Easy Chip Disposal

- The 45° degree slant bed design allows chips to fall directly into the chip tank, avoiding accumulation inside the machine.
- The chip tank employs large wheels, making it easy to move for chip removal and cleaning.
- Chain-type chip conveyor (optional) available on all models.

## MORE POWERFUL

- Powerful main spindle 20HP
- Rigid 45 deg. Slant bed cast iron base

## INCREASED CAPACITY

- 8~10 inch chuck standard
- $\Phi 66\text{mm} \sim \Phi 77\text{mm}$  bar capacity standard

## FASTER/ MORE PRODUCTIVE

- Fast rapid rates 20 ~36m/min
- Spindle speed 8" 4500rpm /10" 3500rpm
- C axis and VDI 30 & VDI 40 & BMT55 live tooling version available

## ERGONOMIC CONSIDERATIONS

- Easy to use membrane touch-pad control station
- Easy moving operator door
- Parts catcher available
- No chip or coolant leaks

## DIRECTLY COUPLED SERVO MOTORS

- T/LTC series servo motors are connected directly to the ball screws with rigid shaft couplings. These couplings ensure that even under severe loading from sharp corner machining, precise interpolation is achieved. This design is superior to both belt driven and flexible shaft coupling designs.

## SPINDLE

- Leadwell produces superior spindles. Built with high precision P4 grade bearings, the one-piece cartridge ensures precise alignment for smooth, run-out free operations.
- The massive headstock, rigid spindle and superior bearing design along with high RPM, all facilitate heavy stock removal and precision tolerances.
- Both the headstock and spindles are machined in a temperature-controlled environment and are assembled in a clean room.

## C-Axis option

By synchronizing the optional C Axis with the live tooling, machining of cylindrical cams and other complex work pieces becomes easy, saving time and money for each part.

The headstock spindle becomes a fully programmable servo axis with the C-Axis option.

- C Axis index resolution: 0.001 degrees
- Max. C-axis speed: 40 rpm
- Switching between normal turning & synchronization with live tooling takes less than 1 second.

## HEADSTOCK

- The headstock is a thermally symmetric design with heat dissipating fins for effectively increasing heat dissipation effect. This design prevents thermal distortion during long machining cycles.

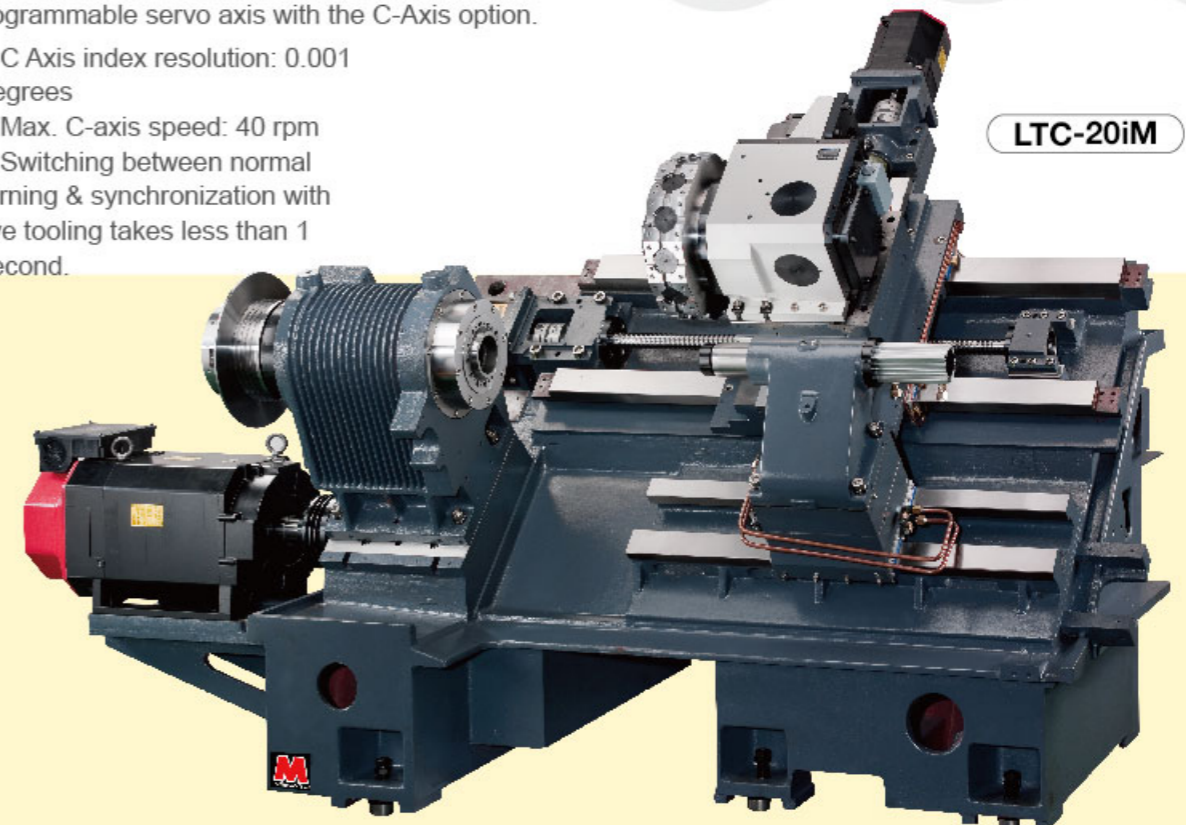
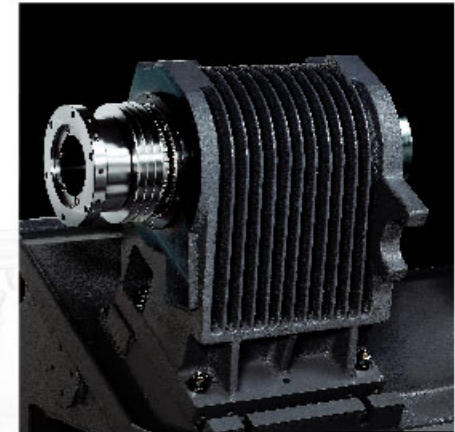

LTC-20iM



# FEA REPORT(Finite Element Analysis)

## Optimum

- Section areas
- Moments of inertia
- Torsional constant
- Plate thickness
- Bending stiffness
- Transverse shear
- Vibration reduce

## With FEA you can

1. Predict and improve product performance and reliability.
2. Reduce physical prototyping and testing .
3. Evaluate different designs and materials .
4. Optimize designs.

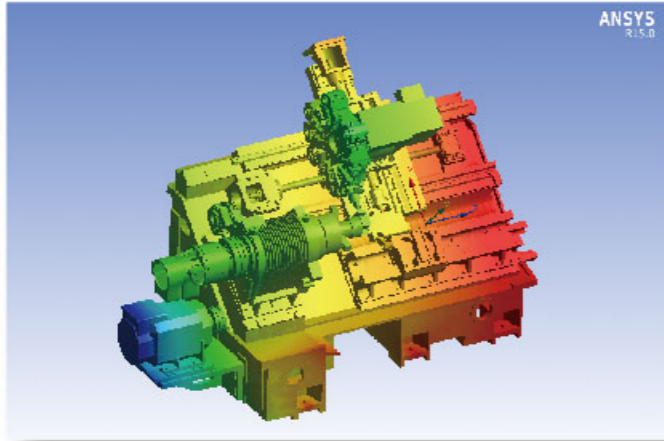

T-7i

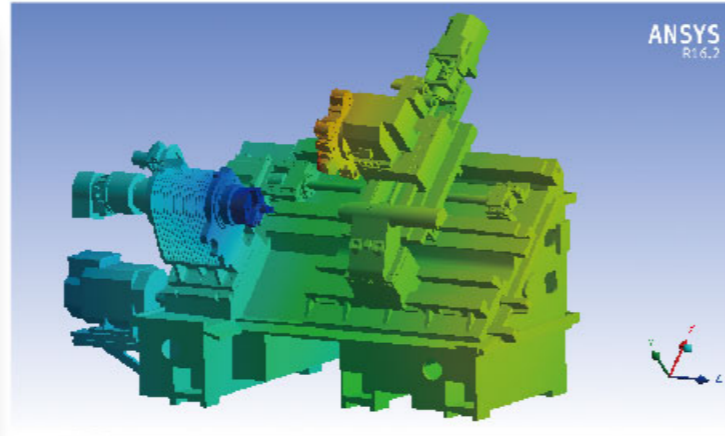

LTC-20i

## CUTTING CAPACITY

### LTC-20i

O.D. Cutting	
Cutting Speed	226m/min
Spindle Speed	750rpm
Feed Rate	0.42mm/rev
Depth of Cut	4mm
Removal Rate	396c.c/min

Drilling	
Tool Size	50mm
Spindle Speed	1000rpm
Feed Rate	0.18mm/rev
Depth of Cut	40mm

Groove Cutting	
Cutting Speed	140m/min
Spindle Speed	428rpm
Feed Rate	0.15mm/rev
Depth of Cut	5mm

Tapping	
Tool Size	M20
Spindle Speed	500rpm
Feed Rate	2.5mm/rev
Depth of Cut	25mm

# FEATURE & QUALITY

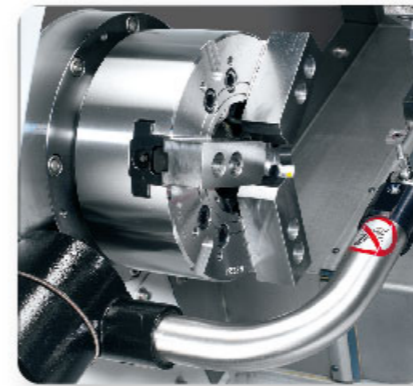

### Tool Setter (Optional)

The tool setter has a touch sensor that can measure various tool lengths and detect broken tools. It can be easily programmed to store all the tool information to reducing tool change time.



### Parts Catcher (optional)

- Leadwell unique parts catcher improves productivity with the bar feeder option.
- The parts catcher automatically rotates to position under the finished part and transfers it outside the operator door. This eliminates the need to stop the machine and retrieve the finished parts.



### Bar Feeder (optional)

The bar feeder is suggested for unattended bar machining and high production requirements. It handles bars ranging from 5 to 65 mm. in diameter. Bar loading can be quickly accomplished. Easy parameter setting for various bar sizes.

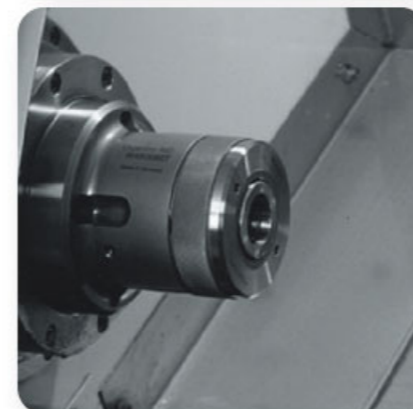

### Collet Chuck (optional)

The spindle is available to mount with a collet chuck, providing faster chucking for bar stock. Various sizes of collet are supplied upon customers' request.

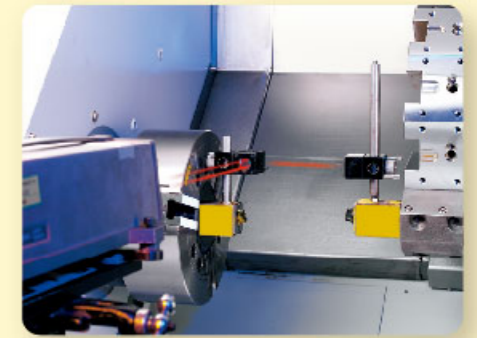

### LASER CALIBRATION

Lasers are used to measure the positioning accuracy of every machine over the full travel of each axis. Leadwell uses these measurements to compensate any axis error so that each machine meets the high accuracy requirements.

- Each machine is shipped with a positioning accuracy chart.

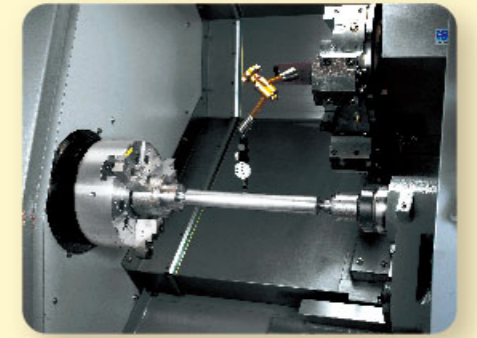

### MACHINE GEOMETRIC CHECKING

Precision indicators are used to verify that spindle run-out and headstock to tailstock alignment meet all specifications.

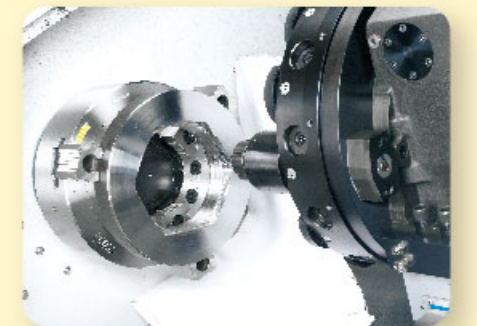

### CUTTING AND COOLANT TESTING

Each machine must complete rigorous cutting tests to ensure machine integrity. Coolant tests guarantee that all components are working properly and machines are 100% leak proof.

### 48 HRS NON-STOP RELIABILITY TEST

Each machines is cycled for 48 hrs to ensure the highest reliability



# SPINDLE POWER CURVE

# OUTLINE DIMENSION

T-7i/T-7iM/T-7iS/T-7iSM

α12/7000i

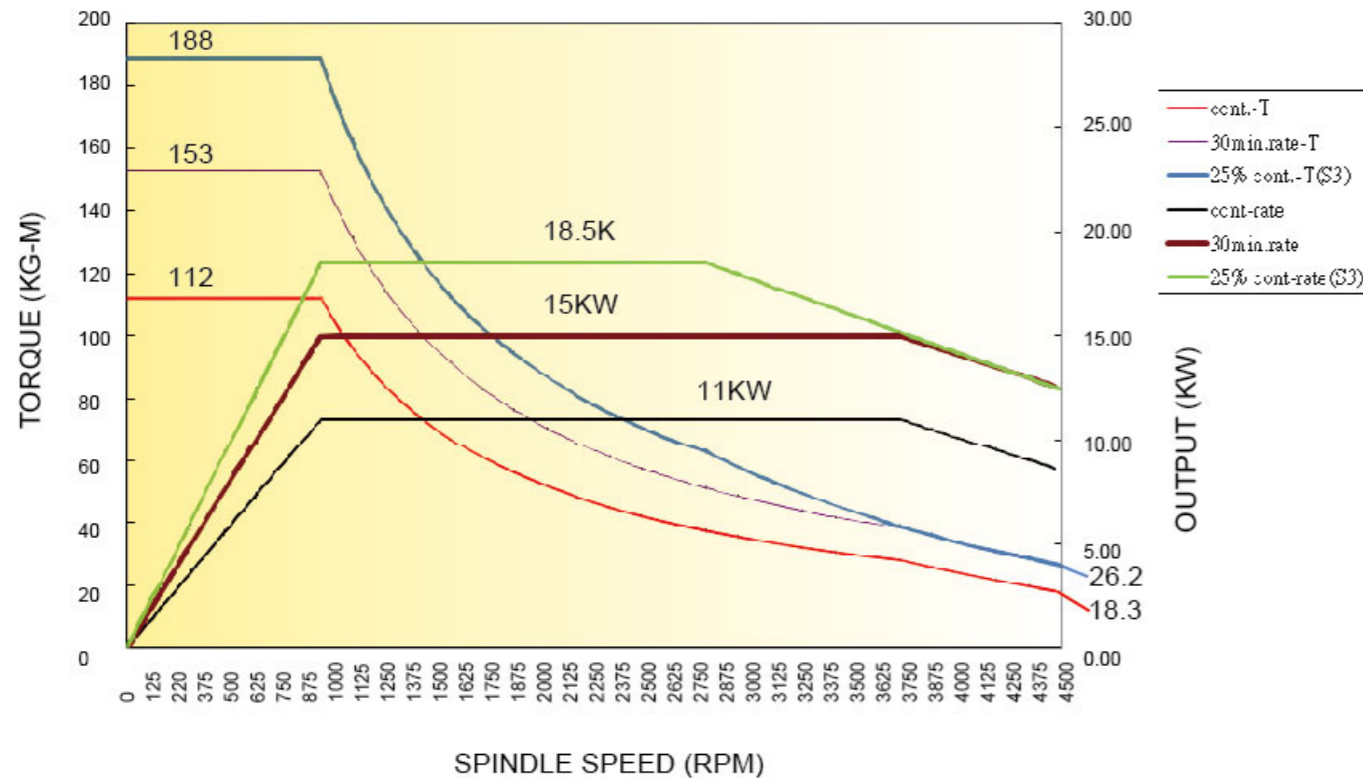

LTC-20i/LTC-20iM

αP30/6000i

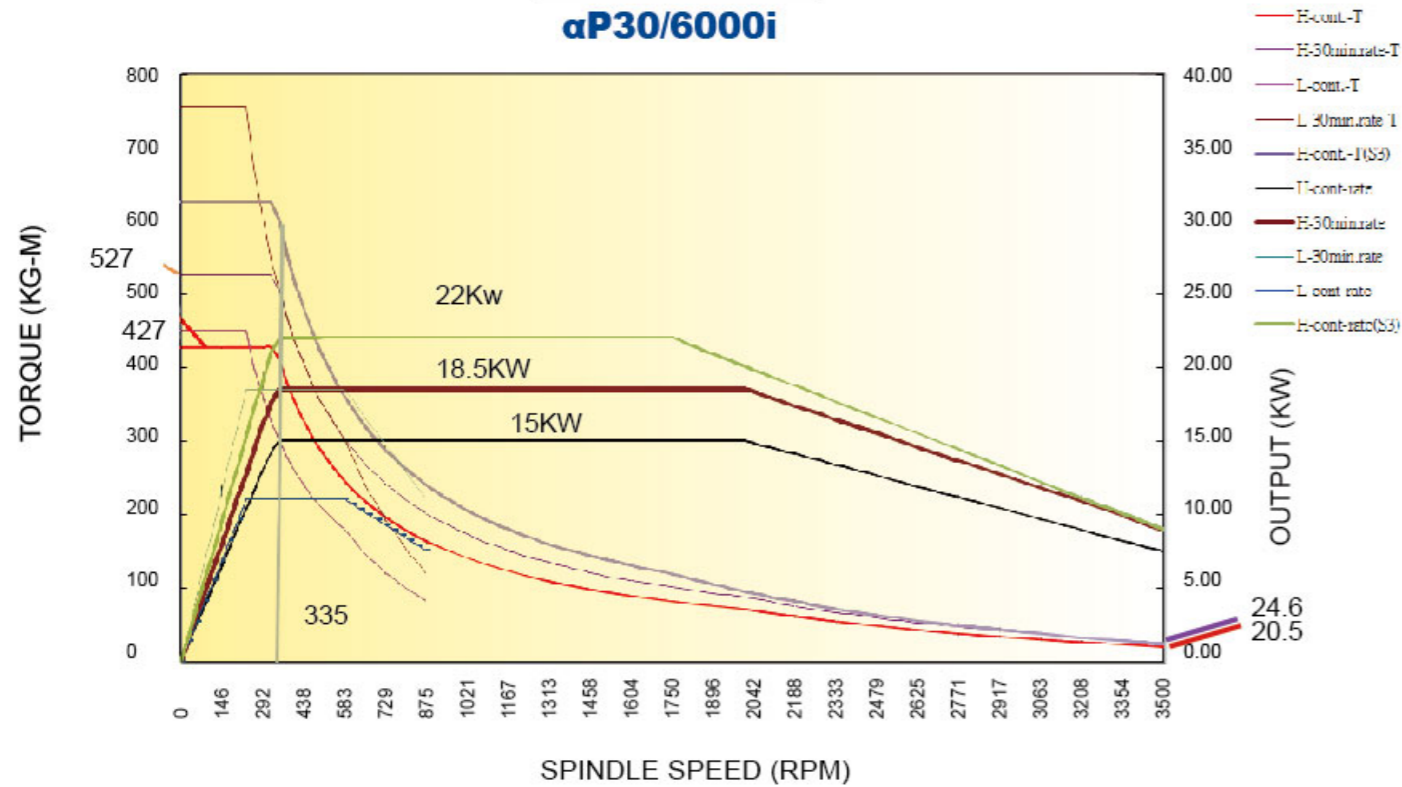

T-7i / T-7i M

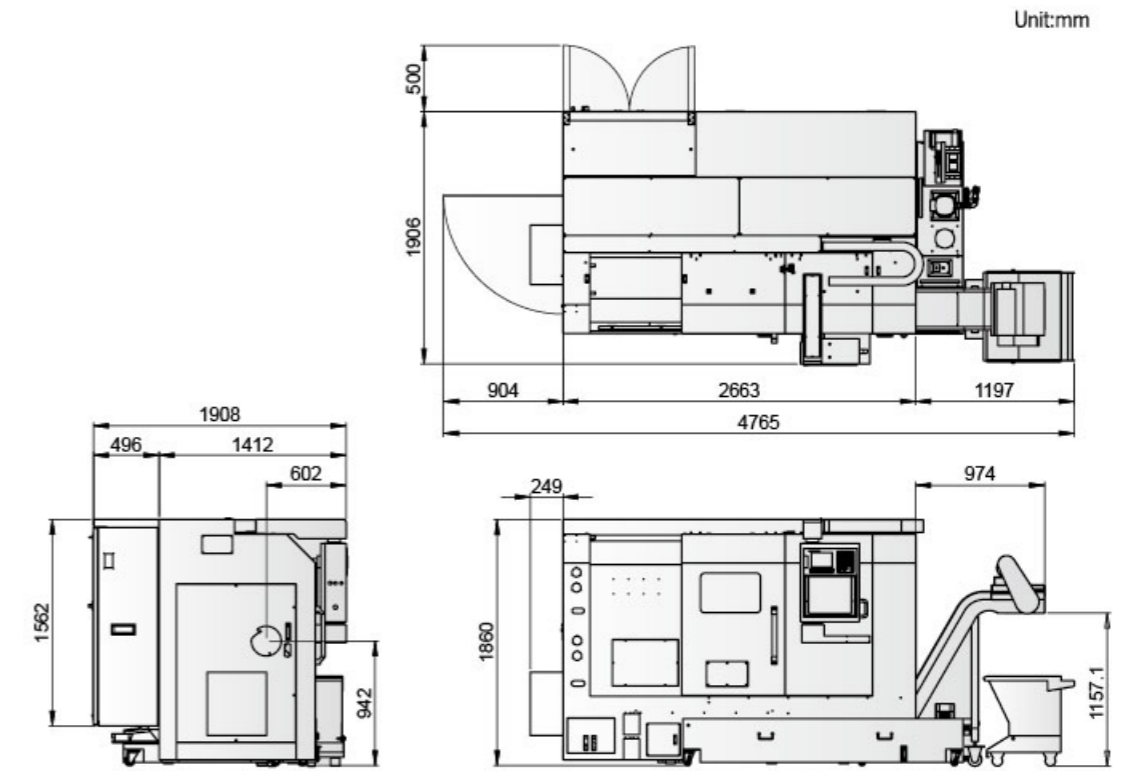

T-7i S / T-7i SM

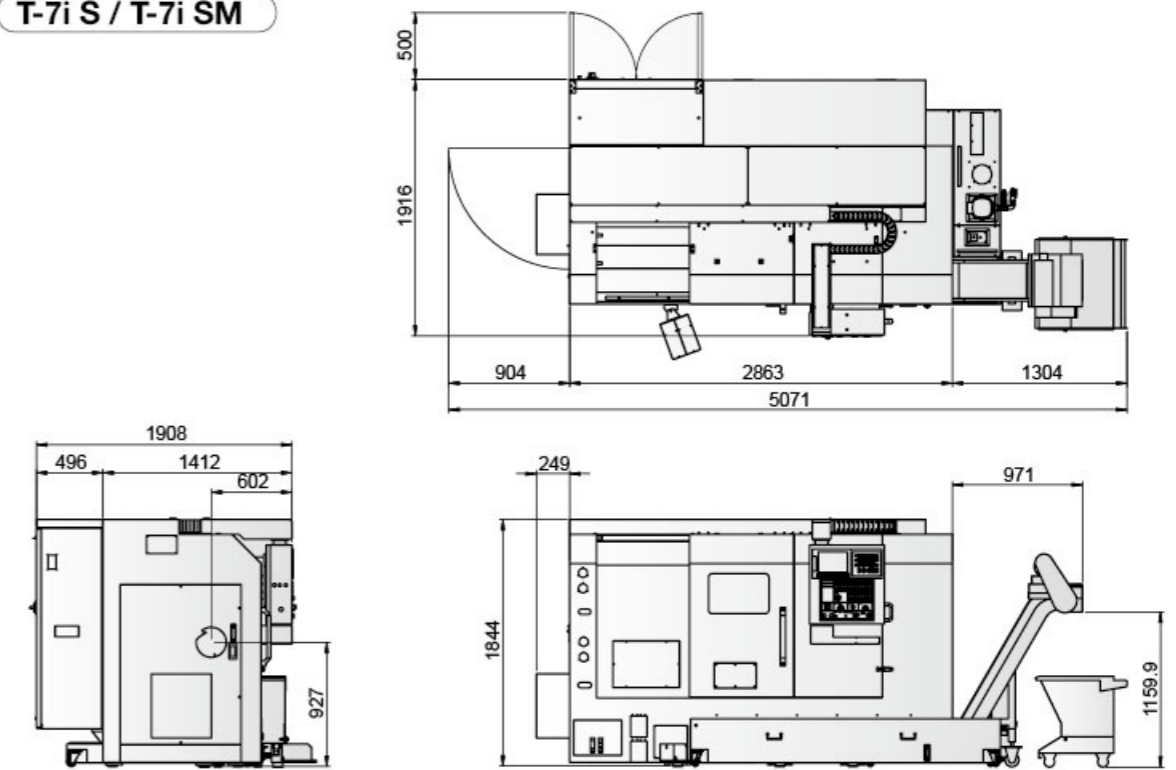

# OUTLINE DIMENSION

LTC-20i/LTC-20iM

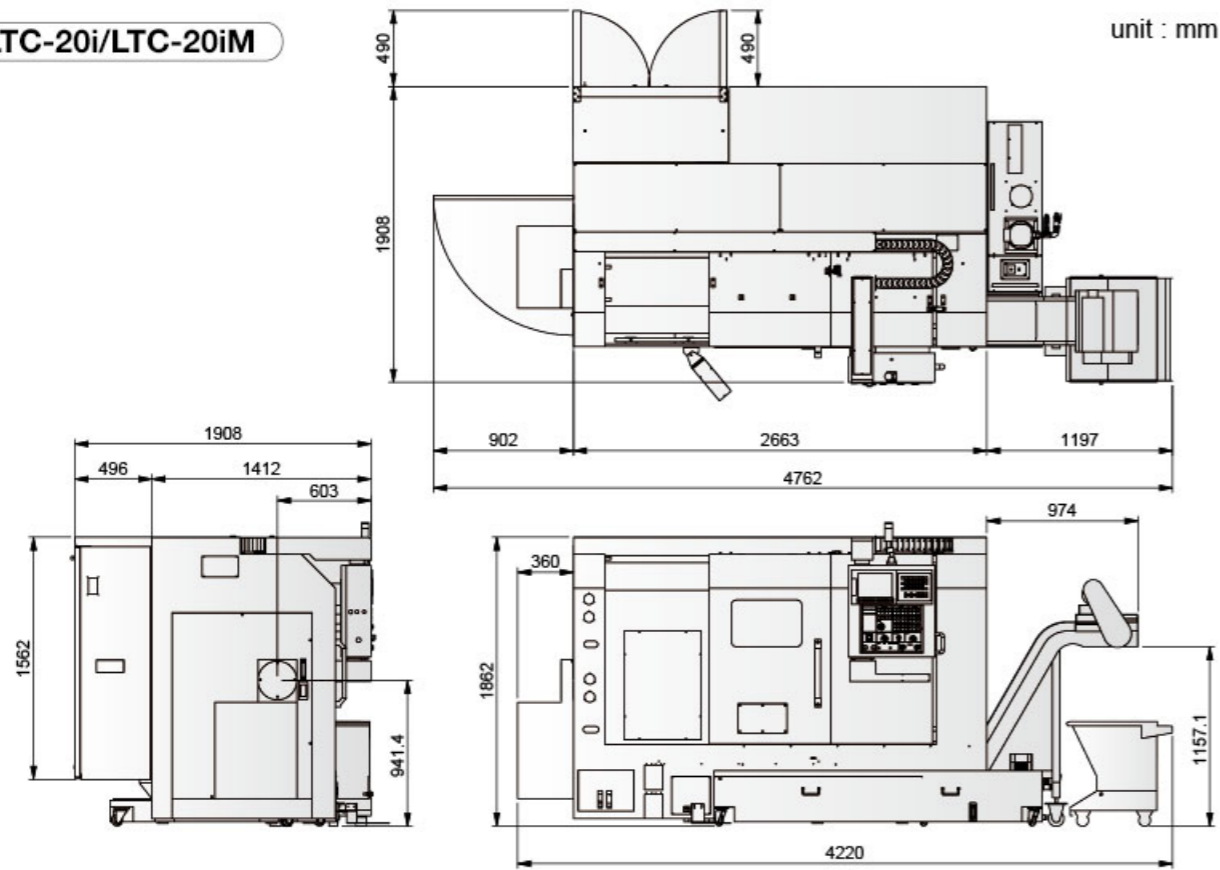

# TOOLING SYSTEM

T-7i

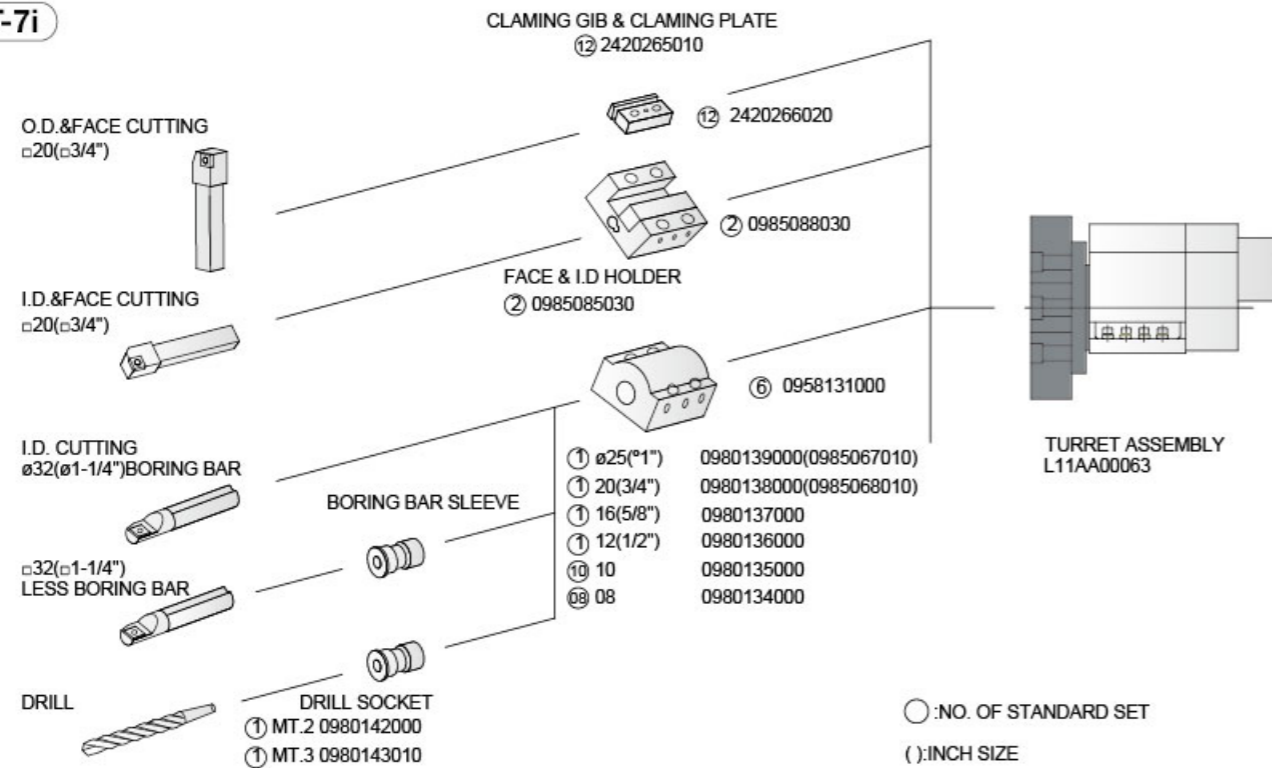

# TOOLING SYSTEM

T-7i S

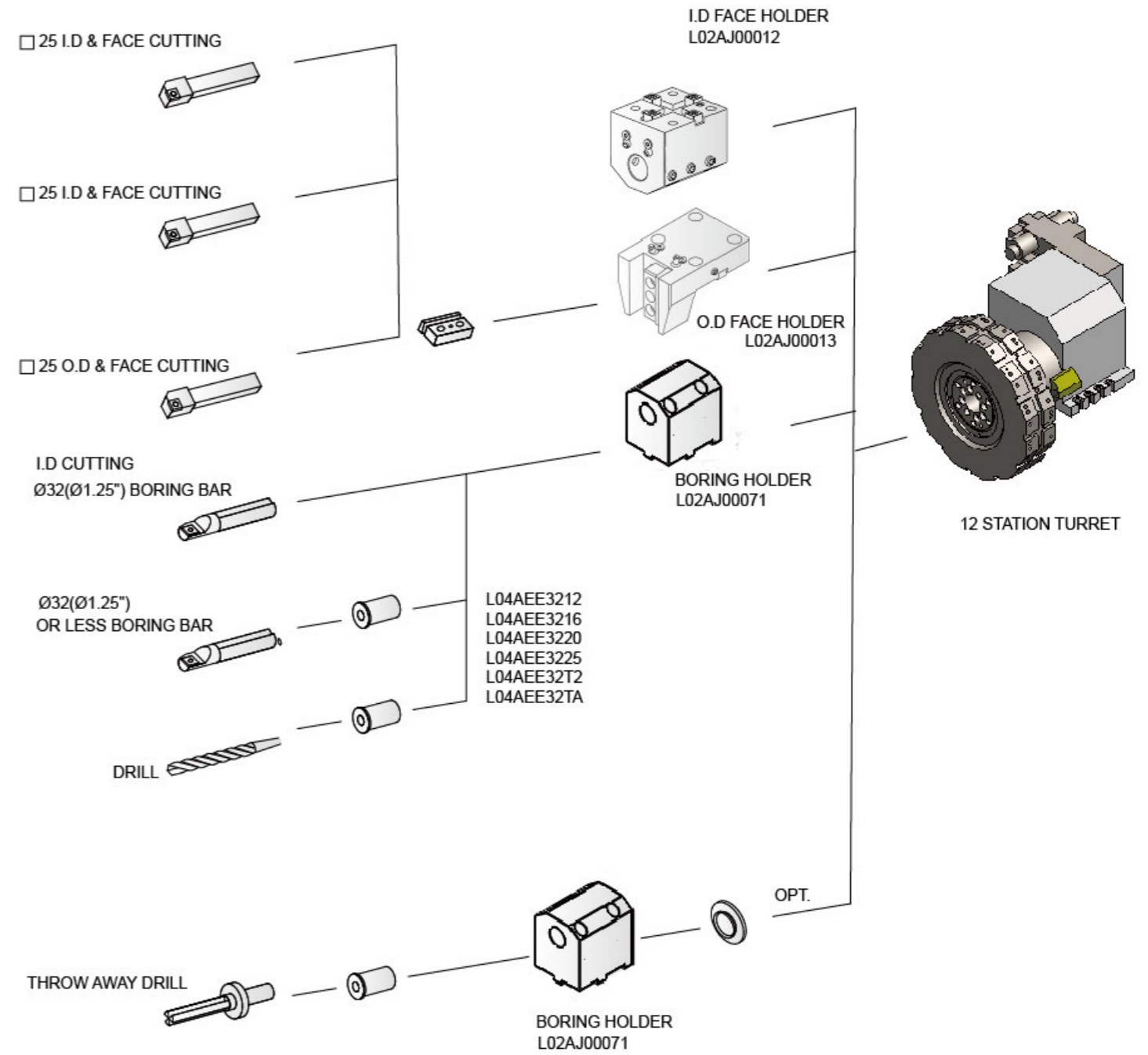



# TOOLING SYSTEM

## T-7i M / T-7i SM(Dupo/VDI)

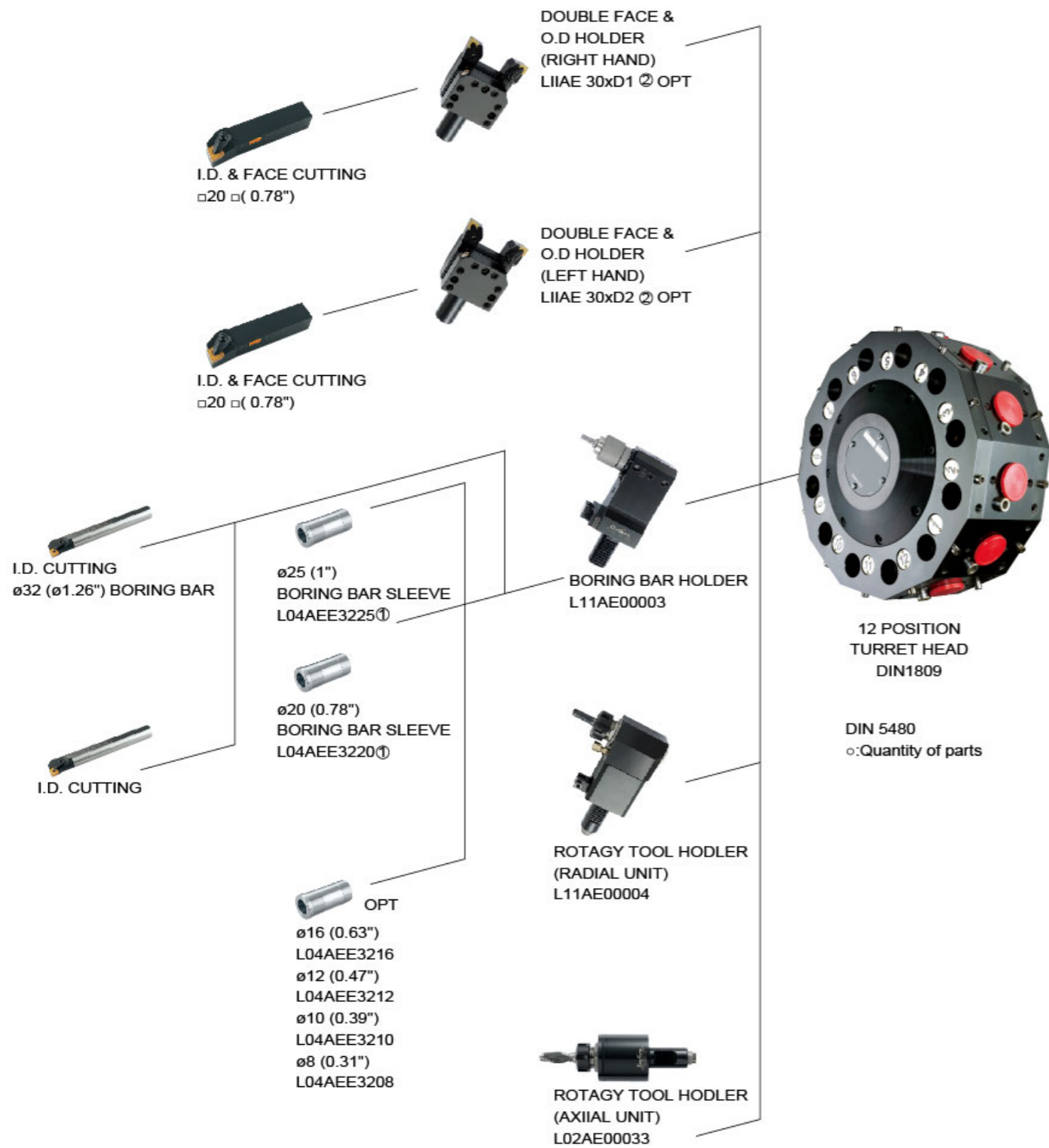

# TOOLING SYSTEM

## T-7i M / T-7i SM(EWS/BMT)

### OPT

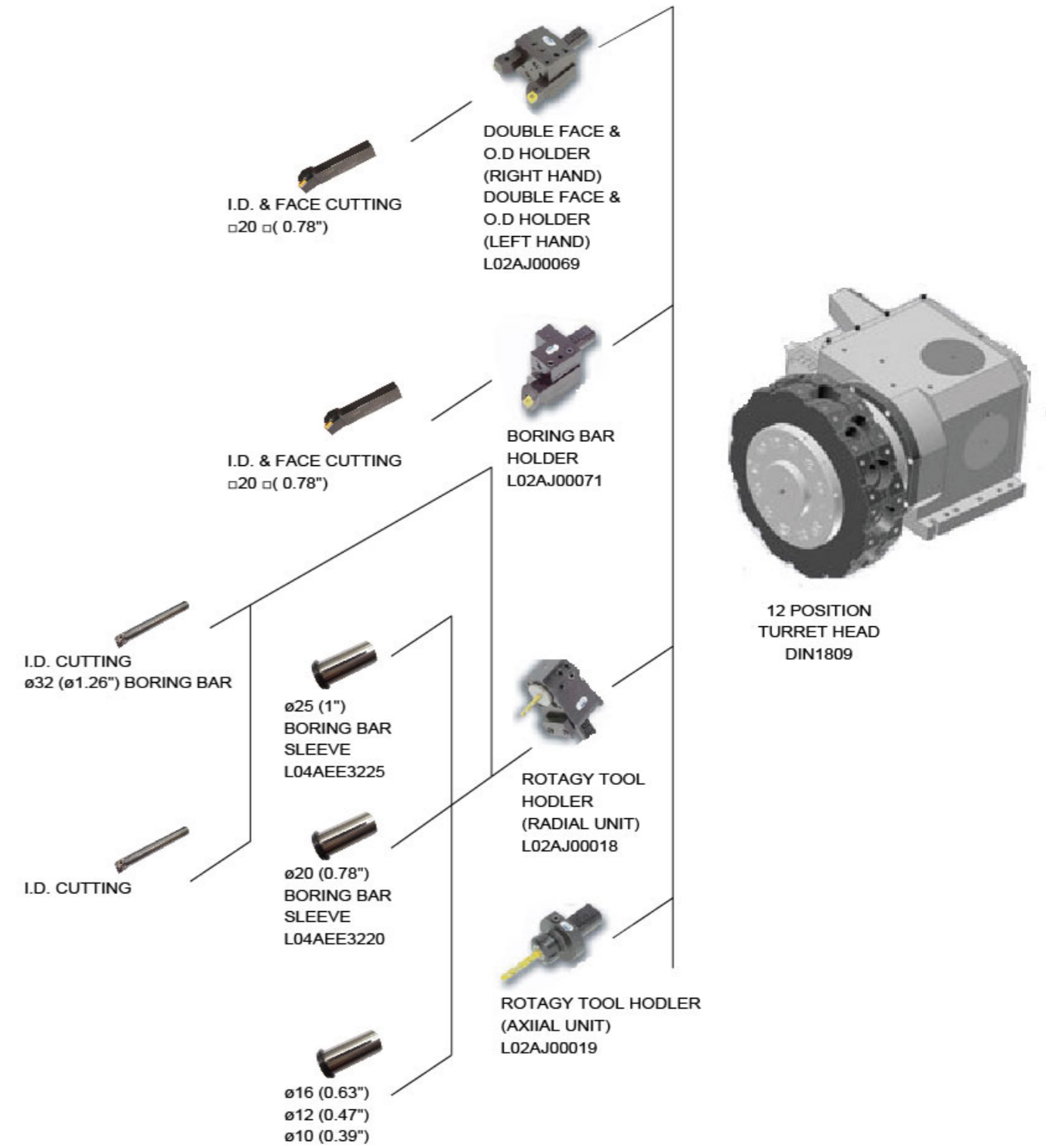

# TOOLING SYSTEM

## LTC-20i

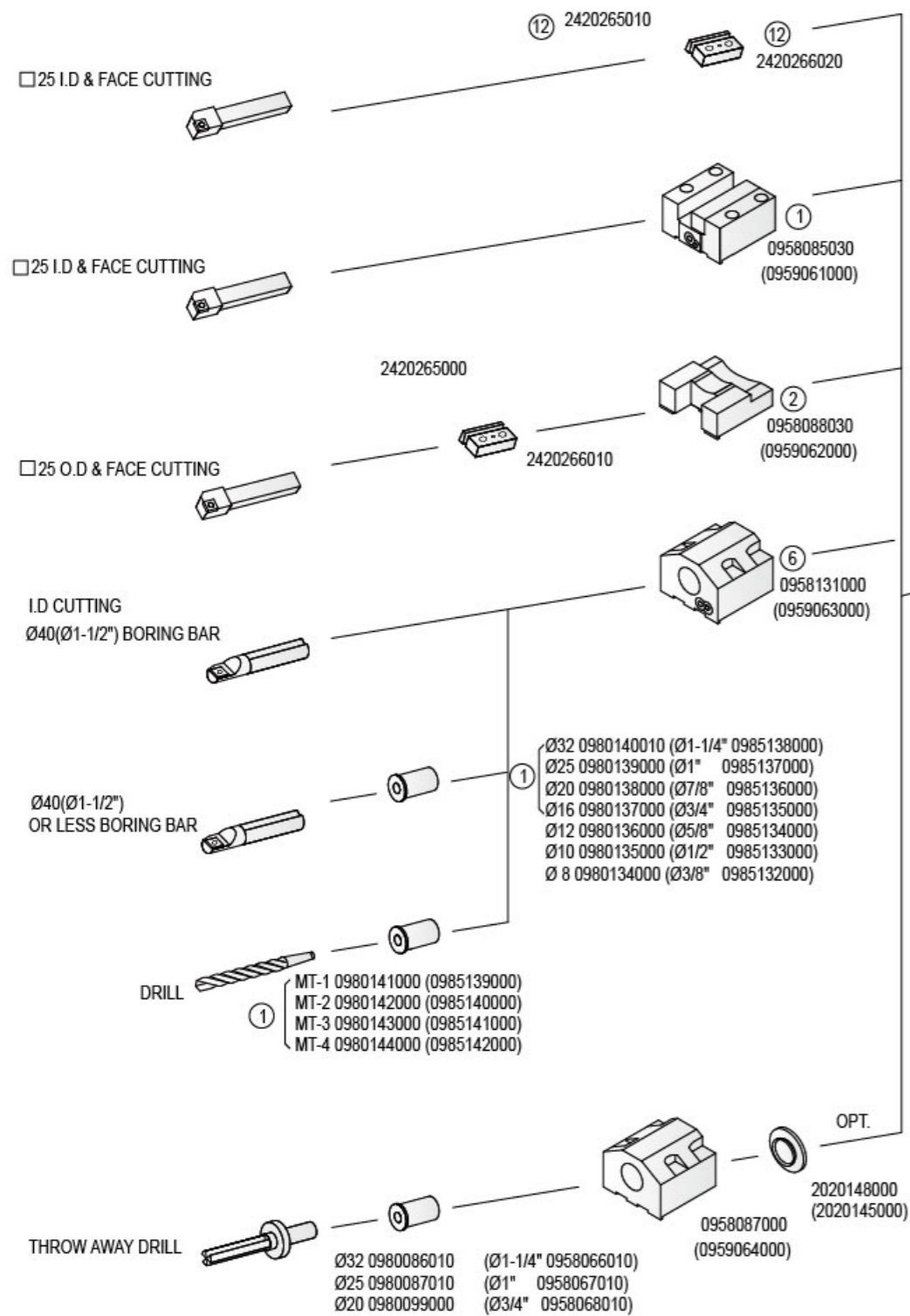

# TOOLING SYSTEM

## LTC-20iM

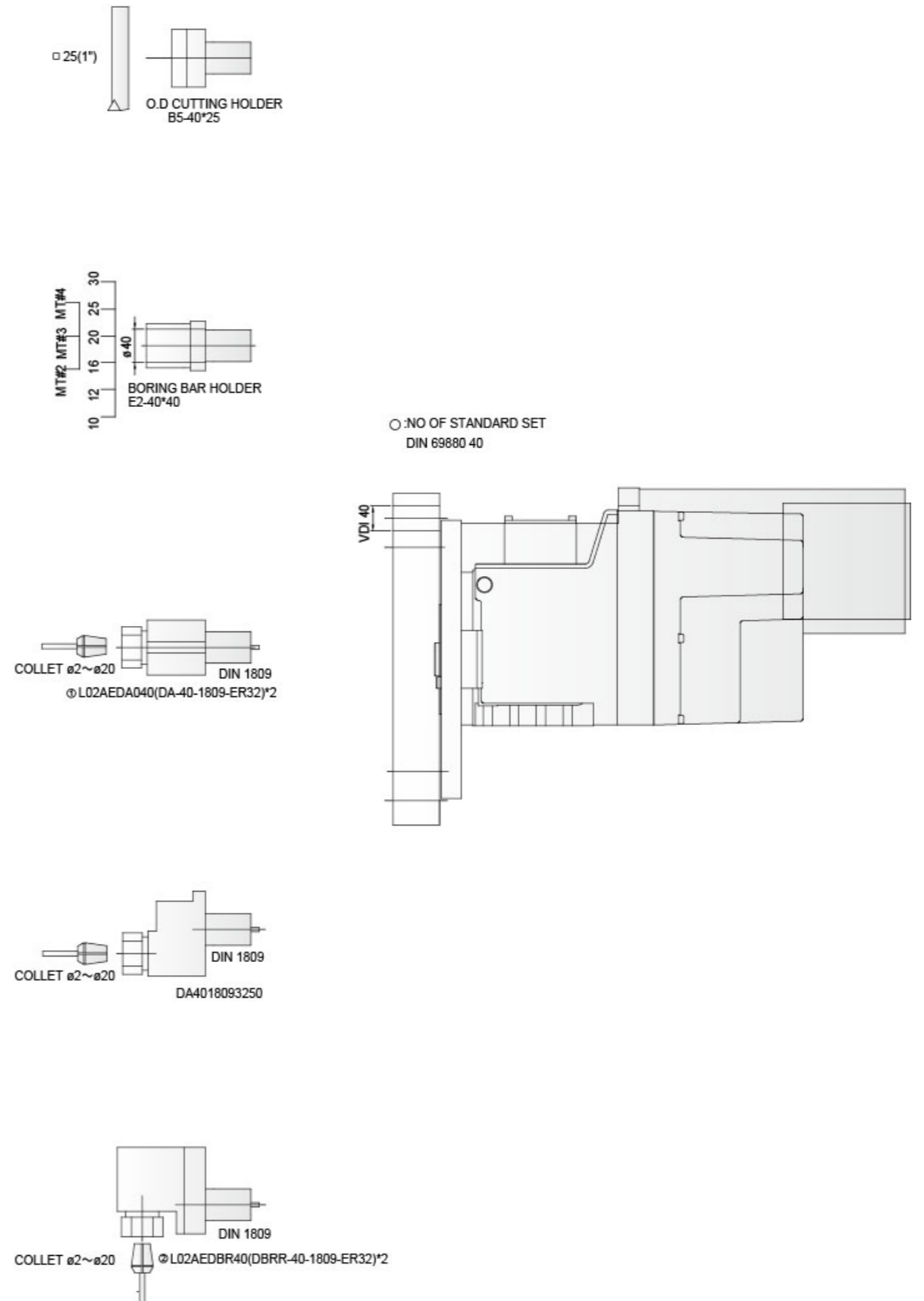



# TOOLING INTERFERENCE

**T-7i**

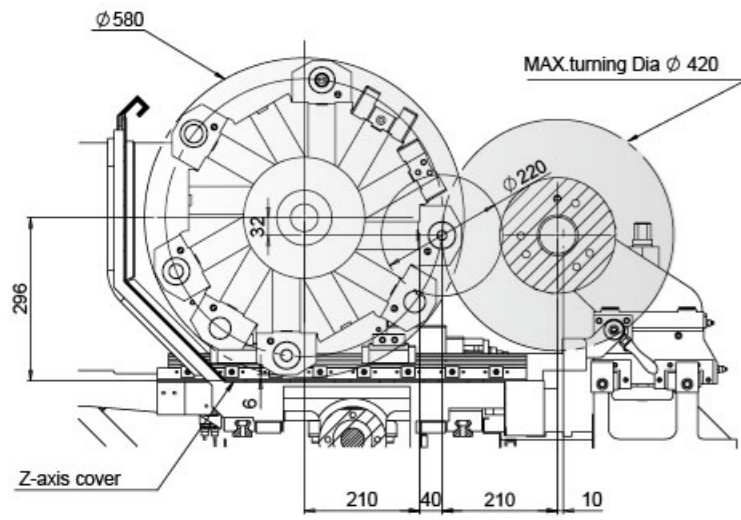

**T-7i S**

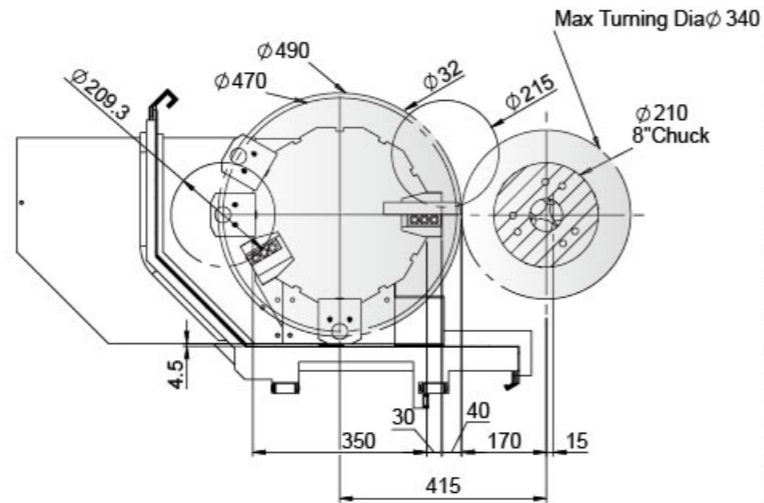

**T-7i M / T-7i SM(Dupo / VDI)**

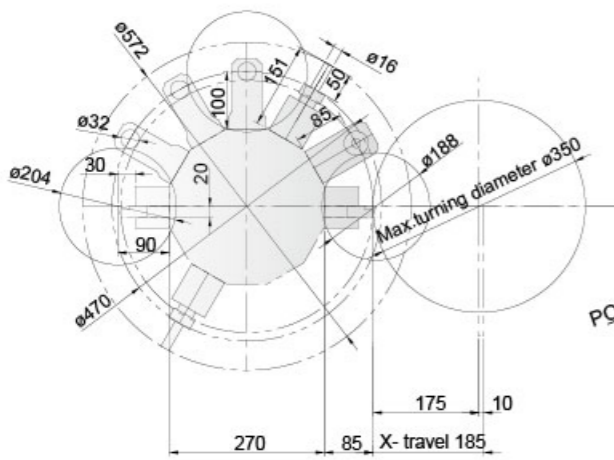

**T-7i M / T-7i SM(EWS/BMT)OPT**

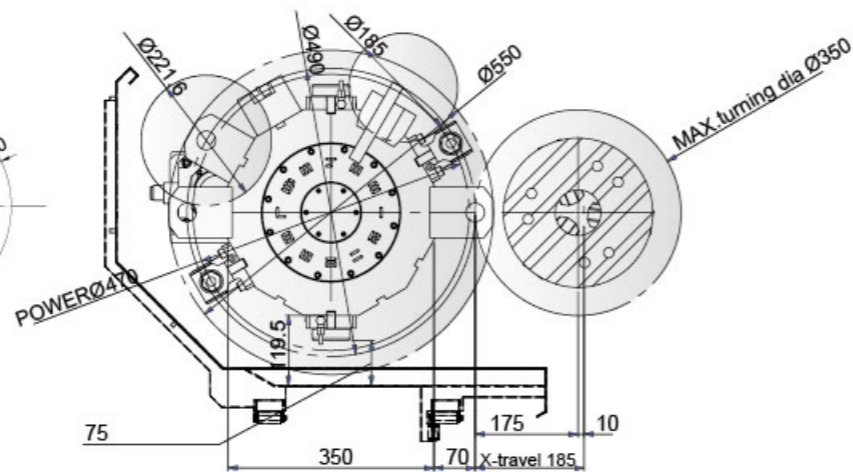

**LTC-20i**

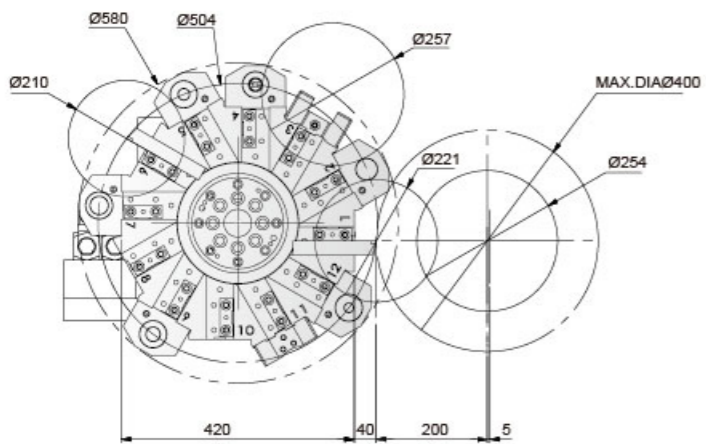

**LTC-20iM**

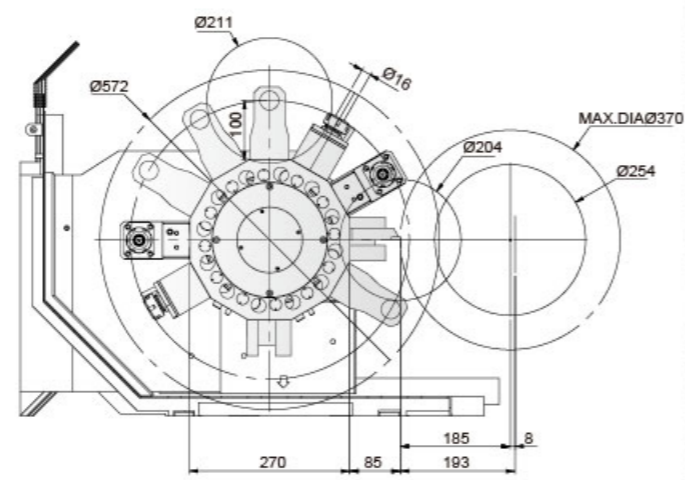

# WORKING CAPACITY

**T-7i**

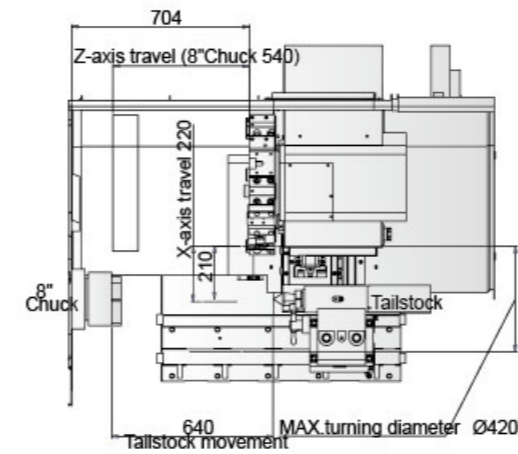

**T-7iM**

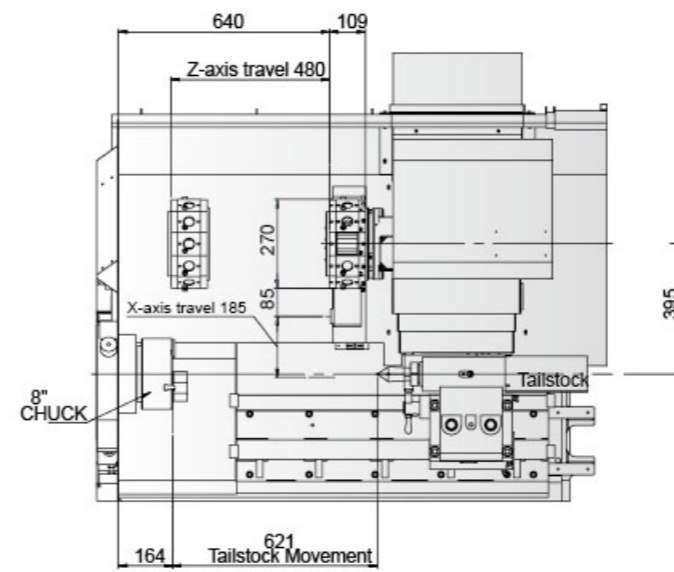

**T-7i S**

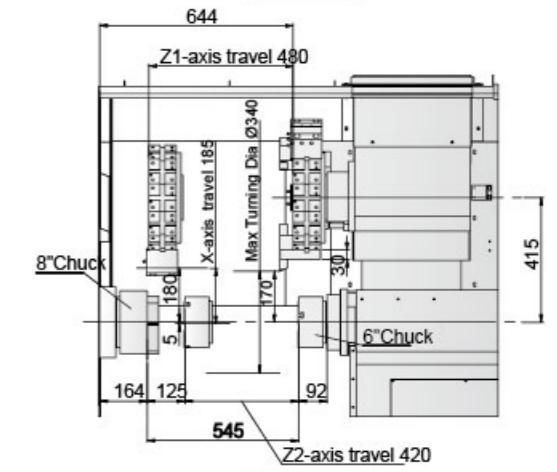

**T-7iSM**

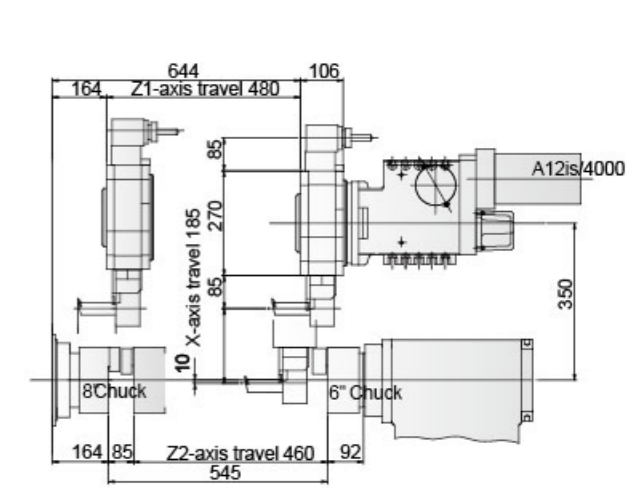

**LTC-20i**

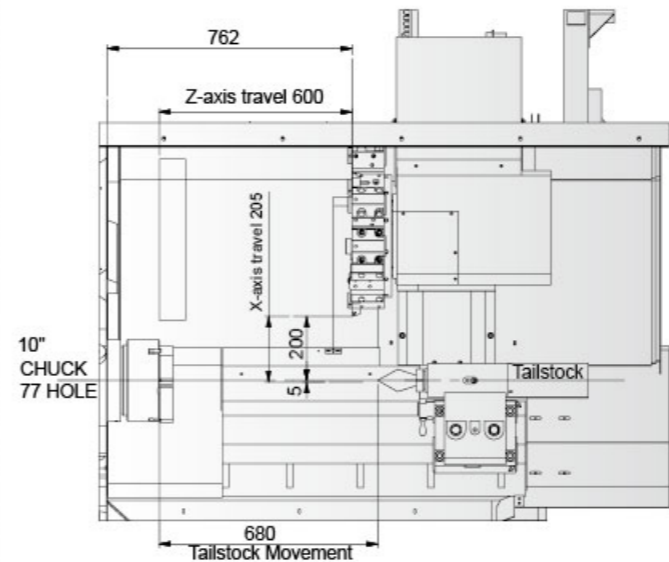

**LTC-20iM**

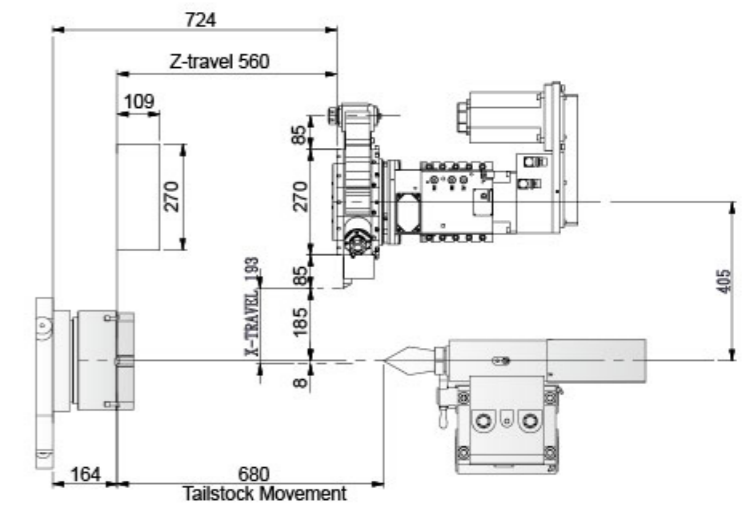



# MACHINE SPECIFICATIONS

ITEM	MODEL	T-7i	T-7iM	T-7iS	T-7iSM
<b>CAPACITY</b>					
Max. swing	mm(in)	520 (20.5)	520 (20.5)	520 (20.5)	520 (20.5)
Max. turning diameter	mm(in)	420 (16.5)	350 (13.7)	340 (13.3)	350 (13.7)
Max. turning length	mm(in)	520 (20.5)	500 (19.7)	480 (18.9)	480 (18.9)
Bar capacity	mm(in)	66 (2.6)	66 (2.6)	66 (2.6)	66 (2.6)
<b>TRAVEL</b>					
X axis travel	mm(in)	210+10 (8.3+0.4)	175+10 (6.8+0.4)	180+5 (7.08+0.2)	175+10 (6.8+0.4)
Z axis travel	mm(in)	540 (21.25)	500 (19.7)	480 (18.9)	480 (18.9)
Z2 axis travel	mm(in)	---	---	460 (18.1)	460 (18.1)
<b>SPINDLE</b>					
Spindle speed	rpm	4500	4500	4500	4500
Chuck size	in	8			
Type of spindle nose		A2-6	A2-6	A2-6	A2-6
Spindle motor type	FANUC	α12-7000i			
Spindle motor power	kw(hp)	15 (20.1)	15 (20.1)	15 (20.1)	15 (20.1)
<b>SUB SPINDLE</b>					
Sub spindle speed	rpm	---	---	4500	4500
Sub chuck size	in	---	---	6	
Type of sub spindle nose		---	---	A2-5	A2-5
Sub spindle motor power	kw(hp)	---	---	7.5 (10)	7.5 (10)
<b>TURRET</b>					
Number of tool stations	pcs	12	12	12	12
Shank height for square tool	mm(in)	25 (1)	20 (0.78) VDI 30 25 (1) BMT 55	25 (1)	20 (0.78) VDI 30 25 (1) BMT 55
Shank diameter for boring bar	mm(in)	40 (1.5)	32 (1.3) VDI 30 40 (1.5) BMT 55	32 (1.3)	32 (1.3) VDI 30 40 (1.5) BMT 55
<b>FEED RATE</b>					
X/Z/Z2 axis rapid traverse	m(in)/min	36/36/-(1417/1417/---)		36/36/20 (1417/1417/787.4)	36/36/20 (1417/1417/787.4)
<b>TAILSTOCK</b>					
Quill diameter	mm(in)	75(3)	75(3)	---	---
Quill inside taper	M.T	4	4	---	---
<b>FEED MOTORS</b>					
X/Z/Z2 axis motor	kw(hp)	3/3/-(4/4/-)		3/3/1.6 (4/4/2.1)	3/3/1.6 (4/4/2.1)
<b>MACHINE SIZE</b>					
Height of machine (H)	mm(in)	1844(72.6)			
Floor space (LXW)	mm(in)	2912x1910(114.6x75.2)		3113x1908(122.5x75.1)	
Total machine weight	kg	4500		4900	
Power requirement	KVA	30	35	45	45
Controller	FANUC	0i-T	0i-T	0i-T	0i-T

\*AVAILABLE CONTROLLER: SIEMENS

## STANDARD ACCESSORIES

- Metric disc
- Manual tailstock
- Buzzer
- Heat exchanger
- Full enclosed splash guard
- 3 jaw open center chuck
- Foot switch
- Wide angle V-belt
- Leveling screws and pads
- Maintenance tool box
- Work light
- Sub spindle air outer blow (T-7iS/iSM)
- VDI disc (T-7iM/iSM)

## OPTIONAL ACCESSORIES

- Transformer
- Parts catcher
- Alarm lamp
- Air conditioner
- Bar feeder
- Auto door
- Spindle air outer blow
- High pressure pump
- Chip conveyor
- Chip bucket
- Collet chuck
- Mist separator
- Oil skimmer
- Tool setter
- 3 jaw close center chuck
- Robot
- H.T.D belt
- Micro V-belt
- Spindle air inner blow
- Automatic workpiece measurement

# MACHINE SPECIFICATIONS

ITEM	MODEL	LTC-20i	LTC-20iM
<b>CAPACITY</b>			
Max. swing	mm(in)	570 (22.4)	565(22.2)
Max. turning diameter	mm(in)	400(15.7)	370(14.6)
Max. turning length	mm(in)	600(23.6)	550(21.6)
Bar capacity	mm(in)	77(3)	77(3)
<b>TRAVEL</b>			
X axis travel	mm(in)	200+5(7.8+0.2)	185+8(7.3+0.3)
Z axis travel	mm(in)	600(23.6)	560(22)
<b>SPINDLE</b>			
Spindle speed	rpm	3500	
Chuck size	in	10	
Type of spindle nose		A2-8	A2-8
Spindle motor type	FANUC	αp30-6000i	
Spindle motor power	kw(hp)	18.5(24.8)	
<b>TURRET</b>			
Number of tool stations	pcs	12	12
Shank height for square tool	mm(in)	25(1)	20(0.87)
Shank diameter for boring bar	mm(in)	40(1.6)	32(1.25)
Rotary tool spindle speed range: axis units	rpm	---	5000
Rotary tool spindle speed range: radial units	rpm	---	5000
<b>FEED RATE</b>			
X/Z axis rapid traverse	m(in)/min	20(787.4)	20(787.4)
<b>FEED MOTORS</b>			
X/Z axis motor	kw(hp)	3/4.5(4/6)	
<b>TAILSTOCK</b>			
Quill diameter	mm(in)	75(3)	75(3)
Quill inside taper	M.T	4	4
<b>MACHINE SIZE</b>			
Height of machine (H)	mm(in)	1862(73.3)	
Floor space (LXW)	mm(in)	3023x1908(119x75)	
Total machine weight	kg	4700	
Power requirement	KVA	40	
Controller	FANUC	0i-T	0i-T

\*AVAILABLE CONTROLLER:SIEMENS

## STANDARD ACCESSORIES

- Metric disc (LTC-20i)
- VDI disc (LTC-20iM)
- Manual tailstock
- Buzzer
- Heat exchanger
- Full enclosed splash guard
- 3 jaw open center chuck
- Foot switch
- Wide angle V-Belt

## OPTIONAL ACCESSORIES

- Transformer
- Programmable tailstock
- Parts catcher
- Alarm lamp
- Air conditioner
- Bar feeder
- Spindle air outer blow
- High pressure pump
- Chip conveyer & bucket
- Collet chuck
- Oil skimmer
- Tool setter
- 3 jaw close center chuck
- Auto door
- Oil mist collector
- Robot