

VERTICAL / 5 - AXIS MACHINING CENTERS



MYCENTER[®]
G SERIES



DESIGNED for . . .

Flexibility to produce parts with optimum efficiency and precision . . .

The **Vertical G Series** is the culmination of excellence in the manufacture of high-performance machine tools that spans over 83 years. This dedication to excellence is grounded in our principles of relentless innovation, state-of-the-art manufacturing techniques and facilities and an unwavering commitment to absolute customer satisfaction.

Kitamura **G Series Vertical and 5-Axis Machining Centers** provide these important benefits:

- Made in Japan quality
- Designed using advanced materials with ultra-high precision techniques
- Space saving footprints
- Operator convenience and ease of use
- High speed processing Arumatik®-Mi CNC Controller



Mycenter-3XG / 3XiG Vertical Machining Centers

*Ideal for small to medium size workpieces.
Available with optional lightning quick 180 degree rotating 2-pallet system.*

Mytrunnion 5-Axis Machining Centers
5-Axis Machining Excellence for today's more intricate, complex machining applications



Shown with optional 100T ATC

Bridgecenter Double Column Machining Centers
Mold builder accuracies with highly rigid, double column bridge-type construction





The Right DESIGN. . .

Superior deflection-free construction, simplicity of operation, unrivaled precision

The right design for the job can mean the difference between profits and losses. Kitamura offers three styles of VMCs, each designed to deliver the flexibility that's right for your application.

Kitamura castings provide critical design benefits:

- Solid Induction Hardened Boxways produced at our factory
- Premium grade Meehanite cast iron
- Solid column construction
- Hand-scraped surfaces for absolute true geometric accuracy
- Zero overhang for guaranteed static accuracies of +/- 0.002mm (+/-0.000079") / full stroke



Mycenter-3XG/3XiG Vertical Machining Centers

Backbone to handle tough cuts

- Thick-walled, heavily-ribbed Meehanite cast construction throughout
- Zero overhang over the entire X-Axis travel

Top View X and Y-Axes Stroke Movement

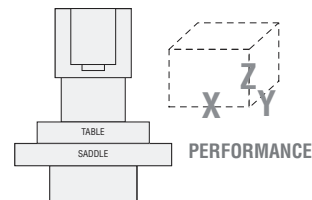
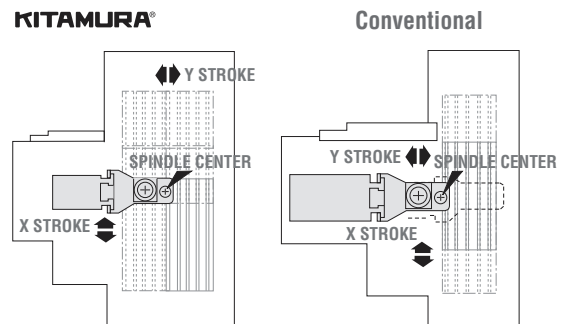

KITAMURA®
Kitamura Fully Supported Table Design Zero table overhang assures full support throughout X-Axis travel for optimum accuracy.

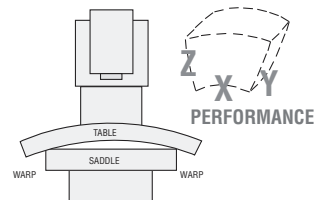

Conventional Table Design
 Table overhang causes deflection and poor accuracy.

Mytrunnion 5-Axis Vertical Machining Centers

Designed for speed and rigidity and flexibility in complex 5-axis machining

- Double column bridge type construction
- Built-in trunnion design allows for maximum stiffness and flexibility with the ability to position the workpiece closer to the spindle

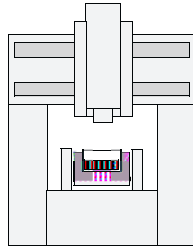

KITAMURA®
Dynamic Double Column Construction Outstanding support and stability even throughout long Y-Axis stroke movement offers exceptional cutting load characteristics and optimum accuracy.

Symmetrical construction extends thermal stability over the Y-Axis travel.



Bridgecenter Double Column Machining Centers

Designed to accommodate heavy, extra-large table loads

- High-rigidity, double housing structure
- Bed-type casting with square section support columns incorporating a triangular section crossbeam
- Proven patented Kitamura design backed by over eighty years of double column machine design experience

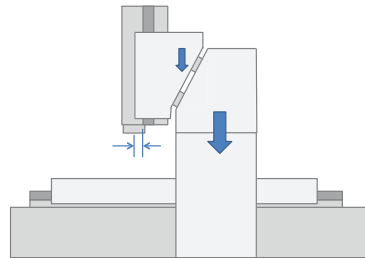

KITAMURA®
Kitamura Patented Triangular Crossrail Construction Evenly distributes headstock weight and cutting forces for chatter-free machining and superior accuracy and surface finishes.

The shorter distance from the Z-Axis slideway to the spindle center offers increased thermal stability over the X-Axis travel.

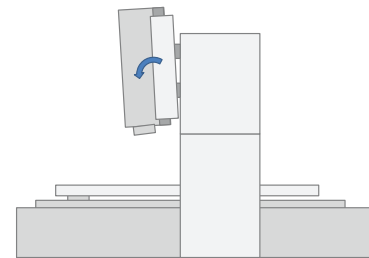

Conventional Construction
 Competitive design is prone to deflection resulting in chatter, and compromised accuracy and surface finishes.





BUILT to Endure

Premium grade components assure long-term quality, precision and reliability.

The best components make for the best machine. That's why Kitamura uses only the finest available. Meehanite Cast structures, drive systems including precision fine pitch ballscrews and servomotors, award-winning spindles, tool and chip handling systems. Every component – from the ground up – must meet or surpass Kitamura's commitment to quality and performance.

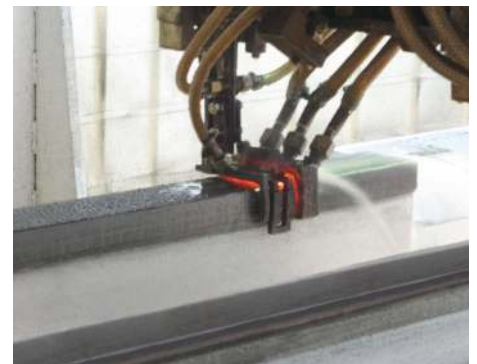

In-house induction hardening assures total process control.

*The color of excellence.
Kitamura is the only
manufacturer that induction
hardens and precision grinds
their solid boxways.*

All structure mating surfaces are precision hand-scraped to assure an absolutely perfect fit. No need for geometry compensation to adjust for squareness, parallelism and perpendicularity.

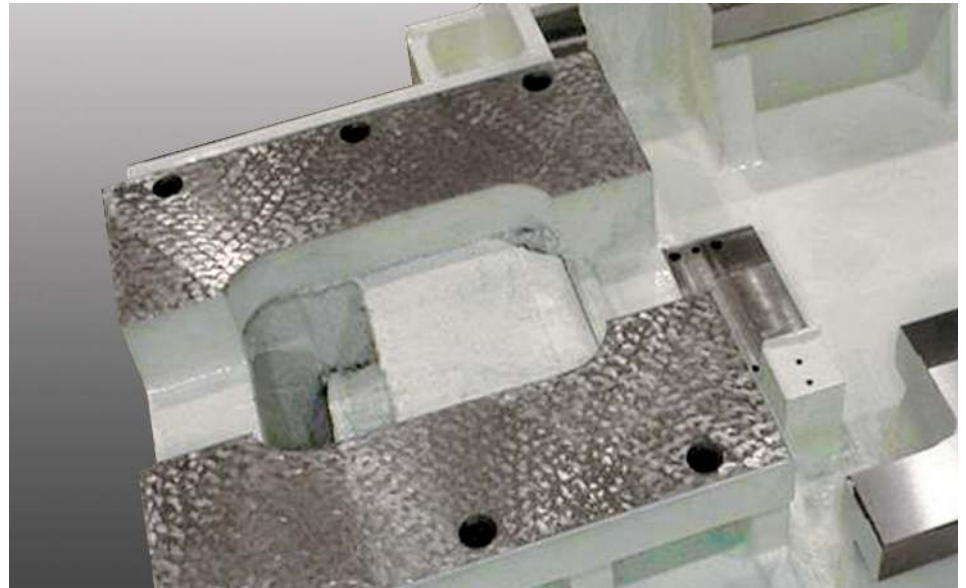

Solid Boxways

- 7 times more surface contact
- 7 times more vibration damping
- Heavier cutting capability

High-precision, pre-tensioned fine pitch ballscrews are precisely temperature regulated to eliminate accuracy robbing thermal growth.

Premium grade servomotors with 16 million pulse encoders deliver astounding $\pm 0.002\text{mm}$ ($\pm 0.000079''$) / full stroke positioning accuracies and powerful drive capability for tough cutting conditions.



POWER for Every Application

Flexibility to produce parts with optimum efficiency and precision . . .

The spindle is the power plant of your VMC. **Mycenter G Series** VMCs are available with a wide variety of spindle configurations to suit your specific metal cutting requirements.

Our Dual Contact spindle system provides simultaneous taper and flange contact for optimum rigidity, improved surface finish and extended cutting tool life. Tight bearing preload assures long-term spindle stiffness. Our gear driven design and efficient oil chiller system dissipate heat, maximizing cutting accuracies and overall spindle life. And they deliver enhanced machining flexibility by delivering low end heavy torque and high-speed fine finish capability.

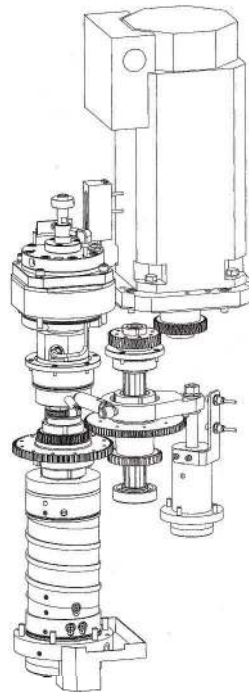

Delivering strong low-end torque and high-end fine finish capability, Kitamura's Multi-Step Gear Driven Spindles deliver unmatched power and energy efficiency for increased productivity and energy savings.



Kitamura has and continues to innovate "ecologically friendly" technology into our machines. Our unique gear driven spindle "sip" energy when compared to other spindle designs, yet deliver more cutting power. This design has earned Kitamura the coveted "20th Japan Industrial Machining Union Chairman Award" for the best energy-saving machine tool technology.

#40 TAPER (*HSK-A63 Option)

	Mycenter-3XG/3XG Sparkchanger	Mycenter- 3XiG/3XiG Sparkchanger	Bridgecenter-6G / 8G	Mytrunnion-4G
Spindle Speed	40 ~ 15,000min ⁻¹	20 ~ 20,000min ⁻¹	20 ~ 20,000min ⁻¹	40 ~ 15,000min ⁻¹ *
Drive Method	Direct Drive	Gear Drive, 4 Step	Gear Drive, 4 Step	Direct Drive
Maximum Spindle Torque	95.5 N•m (70.4 ft•lbs)	133.2 N•m (98.2 ft•lbs)	266.4 N•m (196.5 ft•lbs)	95.5 N•m (70.4 ft•lbs)
Spindle Motor	15kW (20 HP AC/10 min) 7.5kW (10 HP AC/Cont.)	13kW (18 HP AC/15 min) 7.5kW (10 HP AC/Cont.)	22kW (30 HP AC/15 min) 15kW (20 HP AC/Cont.)	15kW (20 HP AC/10 min) 7.5kW (10 HP AC/Cont.)

#50 TAPER (*HSK-A100 Option)

	Bridgecenter-6G/8G/10G/12G	Mytrunnion-7G
Spindle Speed	35 ~ 12,000min ⁻¹ *	35 ~ 12,000min ⁻¹ *
Drive Method	Gear Drive, 4 Step	Gear Drive, 4 Step
Maximum Spindle Torque	585.9 N•m (432.1 ft•lbs)	585.9 N•m (432.1 ft•lbs)
Spindle Motor	40kW (53HP AC/15 min) 22kW (30HP AC/Cont.)	40kW (53HP AC/15 min) 22kW (30HP AC/Cont.)

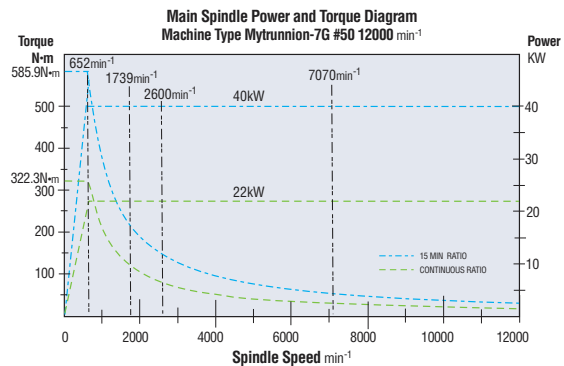
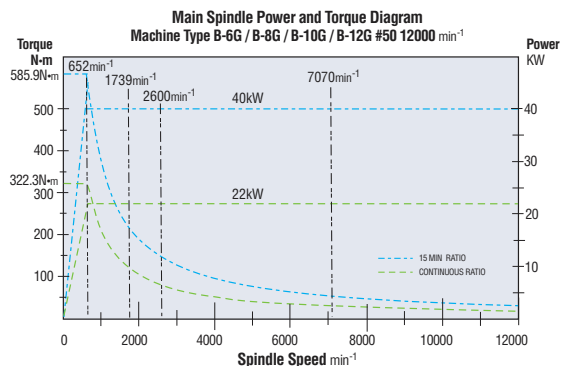
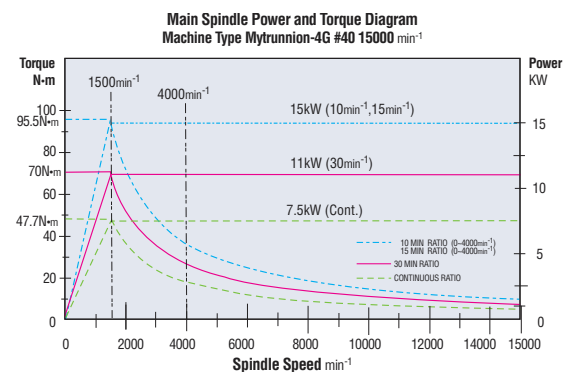
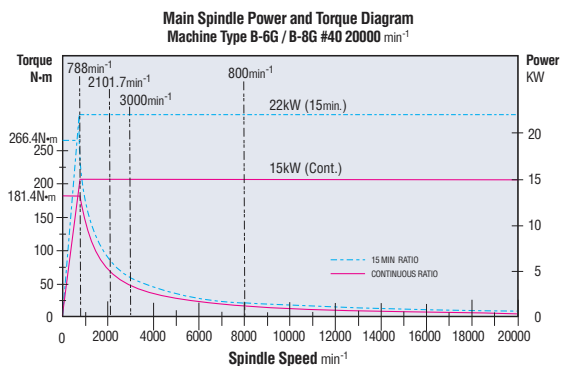
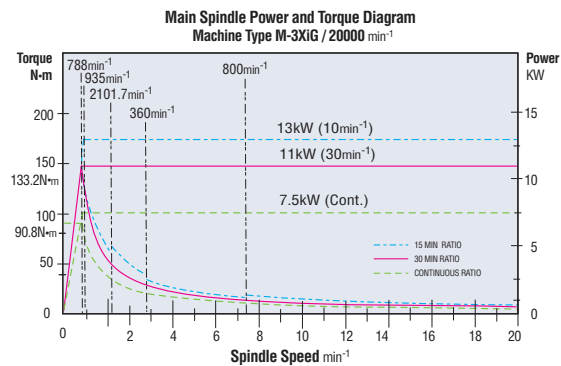
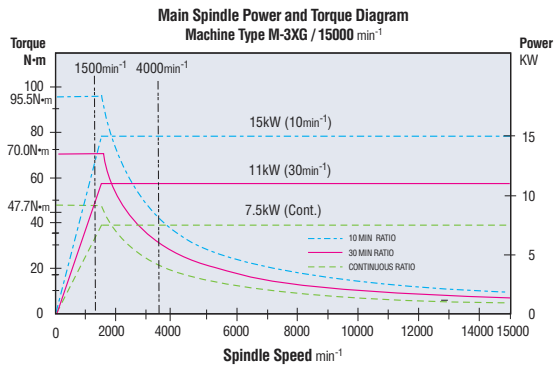



Arumatik[®]-Mi Control

Pioneering Icon CNC Operation . . .

Kitamura's original **Arumatik[®]-Mi** control is as powerful as it is user friendly. By utilizing unique features such as visual work setting screens, maintenance support functions and video guidance on the 19" LCD the Arumatik-Mi control has been designed to maximize operator potential and performance. Advanced operation and ultra-high speed CNC technology mean smoother and faster machining of complex work pieces thanks to the power of High Precision Contour Control with 1680-block look ahead, 2800/blocks per second processing speeds. Designed to handle a variety of machining applications from highly mixed lot, small runs to high volume production work, the Arumatik-Mi offers the user the benefits of a completely customizable and expandable control experience.

- Free Lifetime Software Upgrades
- Maximizes Operator Convenience
- Super-Smooth Control Process
- Customized for Ultimate Productivity
- High Speed Processing
- Fanuc User-Friendly

Unique features such as visual work setting screens, maintenance support functions and video guidance on the 19" LCD the Arumatik-Mi control have been designed to maximize operator potential and performance.

Advanced operation and ultra-high speed CNC technology mean smoother and faster machining of complex work pieces thanks to the power of High Precision Contour Control with 1680-block look ahead, 2800 / blocks per second processing speeds.

The Arumatik-Mi is loaded with a variety of standard control features such as 1280M Memory, 2GB CT/ USB Data Server, 700 Custom MacroVariables, Inverse Time feed, Coordinate System Rotation, 102 Pairs Workpiece Coordinate System, 200 Tool Offsets - Just to name a few.

Free lifetime software upgrades assure continued optimum control features, functions and performance.

Standard Control Specifications

- On Demand "HELP" Guidance
- 19" Color LCD
- Digital User Guide
- Video Guidance
- Job Set Support Functions
- Fine Accel/Decel after Interpolation
- Linear Interpolation (G01)
- Circular/Helical/Spline Interpolation (G02, G03)
- Conical Interpolation (G02.1, G03.1)
- 3-D Circular Interpolation (G02.4, G03.4)
- Circular Cutting (G12, G13)
- Dwell (G04)
- Scaling (G50, G51)
- Extended Workpiece Coordinate System (102 Pairs)
- Single Direction Positioning (G60)
- Coordinate System Rotation (G68, G69)
- Rigid Tapping
- Deep-Hole Tapping Cycle
- Pecking Tapping Cycle
- Small-Diameter Deep-Hold Drilling Cycle
- 3-D Tool Compensation (G40, G41, G42)
- High Speed, High Accuracy Control
- Maintenance Support Function
- Super Smooth Surface (SSS) Control
- 16-Million Pulse Encoder Feedback System
- Background Editing
- Corner Chamfering / Corner Rounding
- Custom Macro B
- Custom Macro Common Variables, 700 Pcs
- 2 GB CF/USB Data Server
- Ethernet Interface
- Extended Editing (Copy, Move, Change, Merge)
- Registerable Programs, 1,000 Sets
- 1280M Memory
- Inverse Time Feed
- Operation Screen Display
- Optional Block Skip
- Playback Function
- Program Restart
- Tangential Speed Constant Control
- Tool Life Management, 400 Sets
- Tool Offset Memory C
- Tool Offset Pairs, 200 Pairs
- Tool Retract and Return
- Tool Monitoring / Adaptive Control
- Backlash Compensation





Arumatik[®] Mi Control

Exciting new features and functions.
The latest in controller technology at your fingertips.

NEW! User Customized Main Menu Touch Screen



HELP

Auto call-up of instructional information



Custom Action Buttons (CAB)
User customized Machine Actions

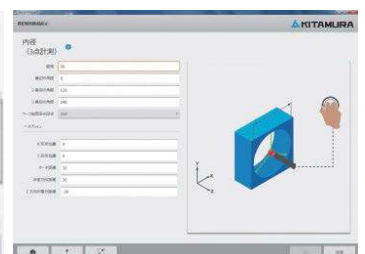
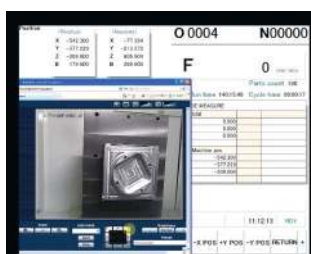
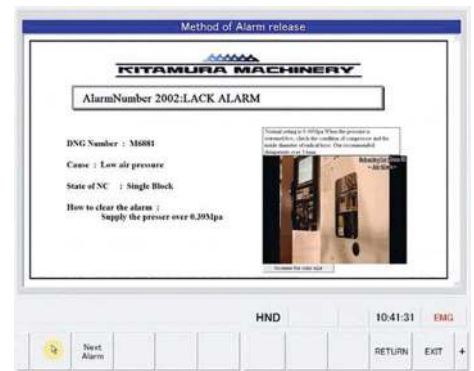
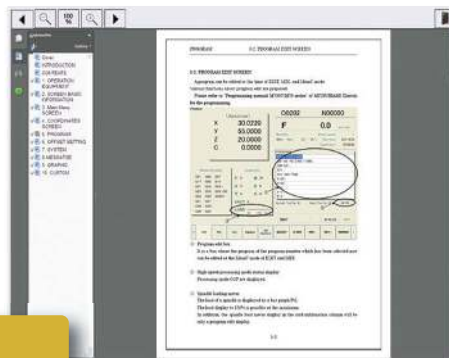

Convenient Visual Programming Screens

A variety of visual programming screens and functions offer the operator faster and easier methods of part set-up and processing for increased productivity. Set-up icon screens, camera functions, data highlight functions, remote monitoring screens, simplified probing interface and electronic manuals in PDF format ensure all information required is at your fingertips.



Kitamura Monitor / Adaptive Control

Detects tool wear and controls cutting feedrate automatically by monitoring live spindle load during machining. By adapting to the change in cutting conditions tool life is maximized and cycle time is shortened dramatically.

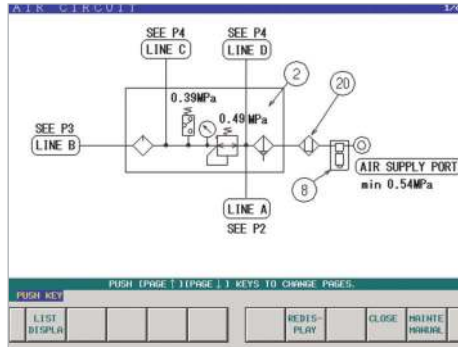
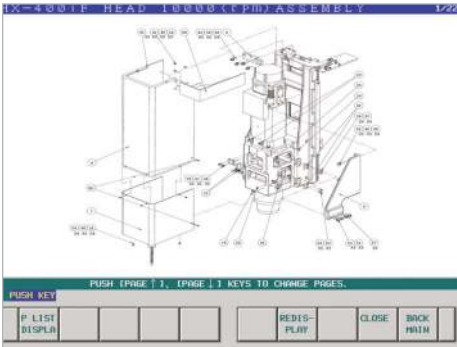

Maintenance Support Function

Kitamura's Maintenance Support Function offers operator convenience in displaying methods of machining maintenance, repair and parts support on the NC Screen.

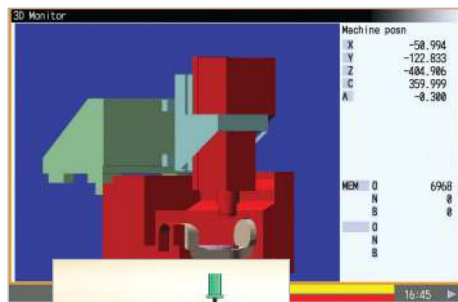
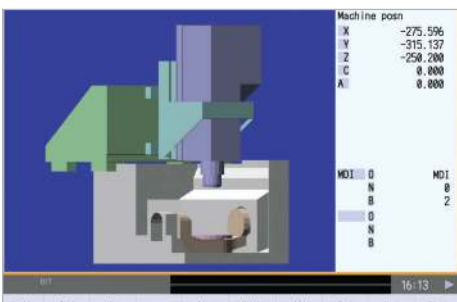

Collision Safety Function

Signals the machine to decelerate in any given movement and lessens the impact should the machine encounter a crash. Although this feature does not avoid the effects of a crash completely, it lessens the damage to the machine as a result.

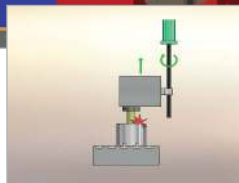

Should the machine crash, this feature automatically reverses the direction of the machine movement.

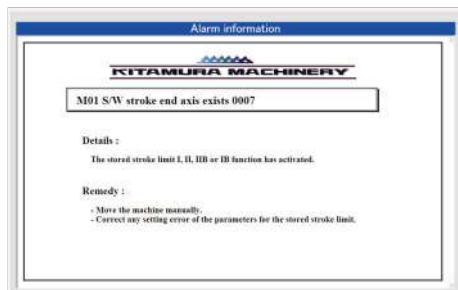

Video Guidance

Useful functions visually walk the user through methods of battery replacement, alarm release, APC recovery, PMC ladder and alarm release/guidance making it easier to monitor machine performance and ensure uptime.





Mycenter® 3XG/3XiG Vertical Machining Centers

Ideal for small to medium size work pieces. Available with Kitamura's patented 180 degree rotating 2-APC system.

Backbone to handle the tough cuts, the **Mycenter-3XG/3XiG G Series Vertical Machining Centers** feature thick-walled, heavily-ribbed box-type Meehanite cast construction throughout. A zero overhang design allows the X-Axis to hold very tight tolerances over the full range of the cutting surface, even the outer edges of the working surface. This assures unparalleled accuracy in machining complex, contoured shapes. The X, Y and Z axes harness the heavy duty cutting power of induction hardened, precision ground solid box guideways for excellent abrasion resistance and vibration absorption for hard to machine materials. This is your assurance of chatter-free, high-precision, fine finish machining, even under the most demanding cutting conditions. Amazingly, these VMCs boast lightning-fast (50m/min / 1,969ipm) X & Y axes feed rates, adding to your production capability.

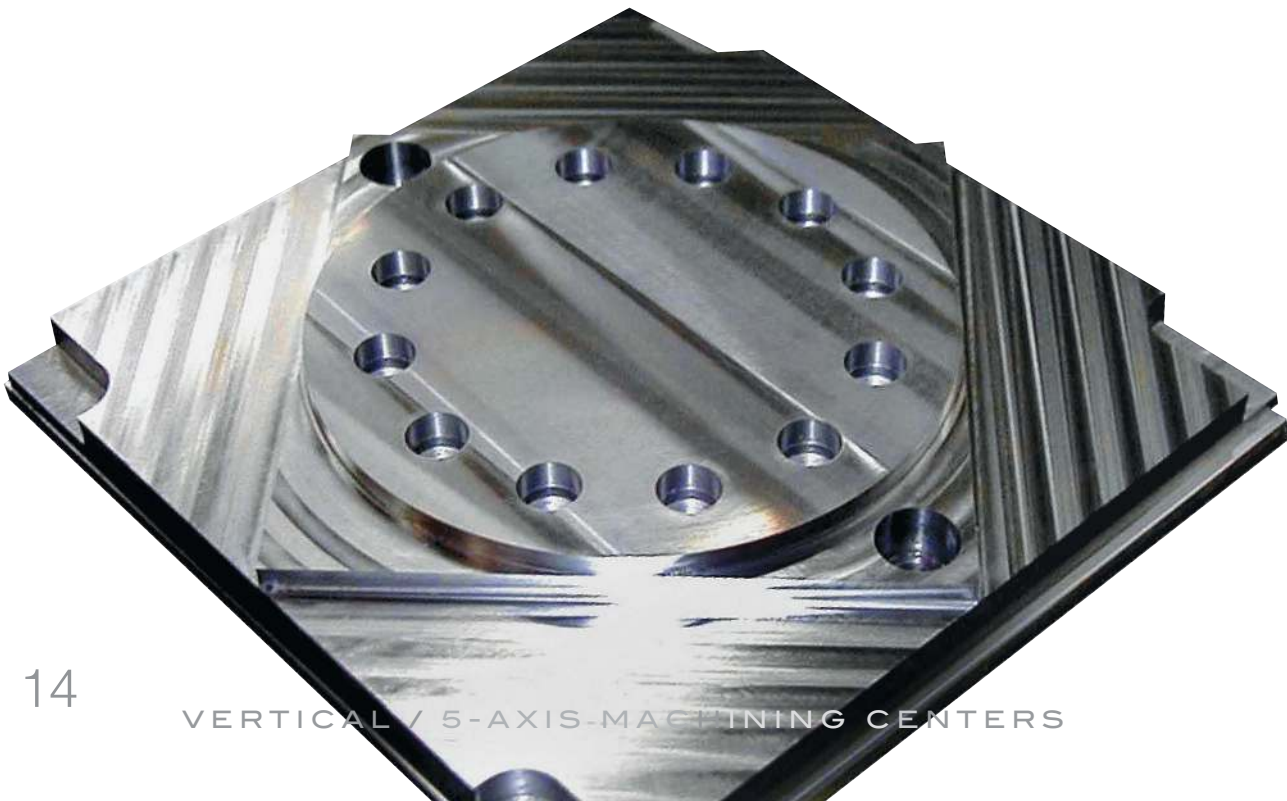

Designed to maximize load and unload of workpieces when the machine is in cycle, the safety and efficiency of workpiece handling, Kitamura's factory installed 2-station, 180 degree rotating pallet changer incorporates fully automatic operation with a quick and consistent 9.3 second pallet change time. With the integration of the pallet changer into a space saving work envelope, Mycenter Sparkchangers are ready for applications that require fast change-over at a moment's notice.



Mycenter-3XG Sparkchanger
Standard 2-Station APC

Mycenter-3XiG
20,000min⁻¹ 4-Step Gear Driven Spindle





Mycenter® 3XG/3XiG Vertical Machining Centers



Efficient tool handling slashes idle time to maximize machining profit. The use of a memory-random tool selection system assures smooth idle-free tool changes. Its generous 30 tool ATC enhances machining capability.



A chip-free machining environment boosts productivity and machining accuracy. A high-efficiency chip management system with overhead wash and base wash coolant and an auger style chip evacuation system is standard. A caterpillar style chip conveyor is an available option.



The spacious work envelope and large table sizes provide the flexibility to machine single or multiple fixtured small to medium sized components. There's ample space to easily expand machining capability with the addition of rotary tables to handle complex 4 and 5 axis work.



Centralized Maintenance Cabinet. All critical maintenance items - lubrication reservoirs, oil chiller, air delivery - are easily accessible for inspection and routine service in a conveniently located cabinet.

SPECIFICATIONS

	Mycenter-3XG	Mycenter-3XG Sparkchanger	Mycenter-3XiG	Mycenter-3XiG Sparkchanger
Table				
Table Size	410 x 900mm (16.1" x 35.4")	410 x 864mm (16.1" x 34.0")	410 x 900mm (16.1" x 35.4")	410 x 864mm (16.1" x 34.0")
T-Slot (Width x Qty.)	18mm (0.7") x 3	18mm (0.7") x 3	18mm (0.7") x 3	18mm (0.7") x 3
Max. Table Load	500kg (1,100 lbs.)	200kg (440 lbs.)	500kg (1,100 lbs.)	200kg (440 lbs.)
Travels				
X-Axis Travel	760mm (29.9")	760mm (29.9")	760mm (29.9")	760mm (29.9")
Y-Axis Travel	455mm (17.9")	455mm (17.9")	455mm (17.9")	455mm (17.9")
Z-Axis Travel	460mm (18.1")	460mm (18.1")	460mm (18.1")	460mm (18.1")
Distance from Table Top to Spindle Nose	110 to 570mm (4.3" to 22.4")	130 to 590mm (5.1" to 23.2")	110 to 570mm (4.3" to 22.4")	130-590mm (5.1" to 23.2")
Distance from Table Top to Column Slideway	215 to 670mm (8.5" to 26.4")	215 to 670mm (8.5" to 26.4")	215 to 670mm (8.5" to 26.4")	215 to 670mm (8.5" to 26.4")
Spindle				
Spindle Taper	#40 NST	#40 NST	#40 NST	#40 NST
Spindle Speed	40 ~ 15,000min ⁻¹	40 ~ 15,000min ⁻¹	20 ~ 20,000min ⁻¹	20 ~ 20,000min ⁻¹
Drive Method	Direct Drive System	Direct Drive System	Gear Drive, 4 Step	Gear Drive, 4 Step
Maximum Spindle Torque	95.5 N•m (70.4 ft•lbs)	95.5 N•m (70.4 ft•lbs)	133.2 N•m (98.2 ft•lbs)	133.2 N•m (98.2 ft•lbs)
Spindle Motor	15kw (20 HP AC/10 min)	15kw (20 HP AC/10 min)	13kw (18 HP AC/15 min)	13kw (18 HP AC/15 min)
Feed				
Rapid Feed X & Y Axes	50m/min (1,969ipm)	50m/min (1,969ipm)	50m/min (1,969ipm)	50m/min (1,969ipm)
Rapid Feed Z-Axis	36m/min (1,417ipm)	36m/min (1,417ipm)	36m/min (1,417ipm)	36m/min (1,417ipm)
Cutting Feed	36m/min (1,417ipm)	36m/min (1,417ipm)	36m/min (1,417ipm)	36m/min (1,417ipm)
APC				
Number of Pallets		2		2
APC Change Time		9.3 seconds		9.3 seconds
ATC				
Tool Storage Capacity	30	30	30	30
Tool Selection Method	Memory Random	Memory Random	Memory Random	Memory Random
Tool Holder Style	CT (BT) 40	CT (BT) 40	CT (BT) 40	CT (BT) 40
Max. Tool Dia.	Ø75 x 300mm (Ø2.95" x 11.81")	Ø75 x 300mm (Ø2.95" x 11.81")	Ø75 x 300mm (Ø2.95" x 11.81")	Ø75 x 300mm (Ø2.95" x 11.81")
w/ Adj. Pots Empty	Ø150 x 300mm (Ø5.91" x 11.81")	Ø150 x 300mm (Ø5.91" x 11.81")	Ø150 x 300mm (Ø5.91" x 11.81")	Ø150 x 300mm (Ø5.91" x 11.81")
Max. Tool Weight	8kg (17.6 lbs.)	8kg (17.6 lbs.)	8kg (17.6 lbs.)	8kg (17.6 lbs.)
Tool to Tool	2.2 seconds	2.2 seconds	2.2 seconds	2.2 seconds
Chip to Chip	4.4 seconds minimum	4.4 seconds minimum	4.4 seconds minimum	4.4 seconds minimum
Machine Dimensions				
Floor Space (W x D)	2,235 x 2,095mm (88.0" x 82.5")	3,377 x 3,066mm (133.0" x 120.7")	2,235 x 2,780mm (88.0" x 109.4")	3,377 x 3,602mm (133.0" x 141.8")
Machine Height	2,883mm (113.5")	3,038mm (119.6")	2,883mm (113.5")	3,038mm (119.6")
Weight				
Machine Weight	5,520kg (12,144 lbs.)	7,320kg (16,104 lbs.)	5,880kg (12,936 lbs.)	7,680kg (16,896 lbs.)
Utilities				
Power Requirement	30 KVA, 200v AC, 3 Phase	30 KVA, 200v AC, 3 Phase	30 KVA, 200v AC, 3 Phase	30 KVA, 200v AC, 3 Phase
Air Requirement	0.5MPa, 300L/min (90psi, 11cfm)	0.5MPa, 300L/min (90psi, 11cfm)	0.5MPa, 300L/min (90psi, 11cfm)	0.5MPa, 300L/min (90psi, 11cfm)
Control				
	Arumatik®-Mi	Arumatik®-Mi	Arumatik®-Mi	Arumatik®-Mi

Specifications subject to change without notice.



BRIDGEcenter

Double Column Machining Centers

The ideal machines for large component processing.

Built on the forty-five year proven Bridgecenter platform, the new **Bridgecenter-G Series Double Column Machining Centers** pack power and capacity into an even more space saving package. These high-capacity machining centers are designed for high-precision machining of extra-large, heavy components. They are ideal for a wide spectrum of applications - from heavy-duty cutting of molds to high accuracy machining of high-tolerance parts. Available in various spindle configurations to meet your exacting requirements.

- Astounding accuracy of +/- 0.002mm (+/-0.000079") / full stroke
- Solid Boxway design with Linear Scale Feedback
- Fastest rapids in bridge style machines
- Space-saving compact footprints

Bridgecenter-8G



Bridgecenter-12G





BRIDGEcenter Double Column Machining Centers



The Bridgecenter Series provide spacious working areas with ample table sizes up to 1,370mm (53.9") x 3,500mm (137.8") and Y-Axis travel of 1,615mm (63.6").



These large working areas in combination with heavy table load capacities up to 6,000kg (13,227Lbs) allow the Bridgecenter-G Series to achieve excellent performance on heavy duty cutting of molds to high accuracy cutting of precise parts.



Bridgecenter-G Series VMCs are equipped with a high-performance Double-Decker style chip disposal system. Twin augers efficiently evacuate chips from the work envelope. This system is up to 50% more efficient than competitive models.

SPECIFICATIONS

	Bridgecenter-6G #40/#50	Bridgecenter-8G #40/#50	Bridgecenter-10G	Bridgecenter-12G
Table				
Table Size	900 x 1,800mm (35.4" x 70.9")	900 x 2,500mm (35.4" x 98.4")	1,370 x 3,000mm (53.9" x 118.1")	1,370 x 3,500mm (53.9" x 137.8")
T-Slot (Width x Qty.)	18mm (0.7") x 7	18mm (0.7") x 7	18mm (0.7") x 5	18mm (0.7") x 5
Max. Table Load	3,000kg (6,600 lbs.)	3,500kg (7,700 lbs.)	6,000kg (13,227 lbs.)	6,000kg (13,227 lbs.)
Distance from Floor to Table Surface	862mm (33.9")	862mm (33.9")	897mm (35.3")	897mm (35.3")
Travel				
X-Axis Travel	1,530mm (60.2")	2,032mm (80.0")	2,540mm (100.0")	3,050mm (120.1")
Y-Axis Travel	1,095mm (43.1")	1,095mm (43.1")	1,615mm (63.6")	1,615mm (63.6")
Z-Axis Travel	710mm (28.0")	710mm (28.0")	800mm (31.5")	800mm (31.5")
Distance from Table Surface to Spindle Nose	152 ~ 862mm (6.0" ~ 33.9")	152 ~ 862mm (6.0" ~ 33.9")	150 ~ 950mm (5.9" ~ 37.4")	150 ~ 950mm (5.9" ~ 37.4")
Distance Between Columns	1,143mm (45.0")	1,143mm (45.0")	1,696mm (66.8")	1,696mm (66.8")
Spindle				
Spindle Taper	Both Models Available in #40 NST and #50 NST		#50 NST	#50 NST
Spindle Speed	20 ~ 20,000min ⁻¹ (#40)	35 ~ 12,000min ⁻¹ (#50)	35 ~ 12,000min ⁻¹	35 ~ 12,000min ⁻¹
Drive Method	Gear Drive, 4 Step	Gear Drive, 4-Step	Gear Drive, 4-Step	Gear Drive, 4-Step
Maximum Spindle Torque	266.4 N•m (196.5 ft•lbs)	585.9 N•m (432.1 ft•lbs)	585.9 N•m (432.1 ft•lbs)	585.9 N•m (432.1 ft•lbs)
Spindle Motor	22kW (20HP AC/15 min) 15kW (20HP AC/Cont.)	40kW (53HP AC/15 min) 22kW (30HP AC/Cont.)	40kW (53HP AC/15 min) 22kW (30HP AC/Cont.)	40kW (53HP AC/15 min) 22kW (30HP AC/Cont.)
Feed				
Rapid Feed X, Y, Z	24m/min (945ipm)	24m/min (945ipm)	24m/min (945ipm)	24m/min (945ipm)
Cutting Feed Rate X, Y, Z	24m/min (945ipm)	24m/min (945ipm)	24m/min (945ipm)	24m/min (945ipm)
ATC				
Tool Storage Capacity	40 Tools (Opt. 60, 80)		40 Tools (Opt. 60, 80)	40 Tools (Opt. 60, 80)
Tool Selection Method	Random bi-directional, Fixed Pot		Random bi-directional, Fixed Pot	Random bi-directional, Fixed Pot
Tool Holder Style	CT (BT) 40	CT (BT) 50	MAS CT (BT) 50	MAS CT (BT) 50
Max. Tool Dia. w/ Adj. Pots Empty	#40 Ø75mm (Ø3.0") #40 Ø127mm (Ø5.0")	#50 Ø125mm (Ø4.9") #50 Ø220mm (Ø8.7")	Ø125mm (Ø4.9") Ø220mm (Ø8.7")	Ø125mm (Ø4.9") Ø220mm (Ø8.7")
Max Tool Length	400mm (15.74")		400mm (15.74")	400mm (15.74")
Max. Tool Weight	#40 10kg (22.0 lbs.)	#50 20kg (44.0 lbs.)	20kg (44.0 lbs.)	20kg (44.0 lbs.)
Tool to Tool	#40 6.6 seconds	#50 6.6 seconds	6.6 seconds	6.6 seconds
Chip to Chip	12.0 seconds, min.		14.0 seconds, min.	15.0 seconds, min.
Utilities				
Power Requirement	#40 35KVA, 200v AC, 3 Phase #50 45KVA, 200v AC, 3 Phase		50KVA, 200v AC, 3 Phase	50KVA, 200v AC, 3 Phase
Air Requirement	0.5 MPa (400L/min) (90 psi, 15 cfm)	0.5 MPa (400L/min) (90 psi, 15 cfm)	0.5 MPa (400L/min) (90 psi, 15 cfm)	0.5 MPa (400L/min) (90 psi, 15 cfm)
Machine Dimensions				
Required Space (W x D)	3,494 x 4,472mm (137.6" x 176.1")	3,494 x 5,866mm (137.6" x 230.9")	4,168 x 7,660mm (164.1" x 301.6")	4,168 x 8,800mm (164.1" x 346.5")
Machine Height	3,885mm (153.0")	3,885mm (153.0")	4,006mm (157.7")	4,006mm (157.7")
Machine Net Weight	17,500kg (38,500 lbs.)	20,000kg (44,000 lbs.)	28,000kg (61,600 lbs.)	31,000kg (68,200 lbs.)
Control				
	Arumatik®-Mi	Arumatik®-Mi	Arumatik®-Mi	Arumatik®-Mi

Specifications subject to change without notice.



Mytrunnion 5-Axis Machining Centers

5-Axis powerhouse for today's more intricate and complex machining applications

Mytrunnion-G Series 5-Axis Machining Centers deliver the exceptionally high levels of accuracies demanded by producers of high-precision complex components. They have the capacity and power to cut the vast array of materials used in today's demanding industries such as aerospace, medical and mold.

- The perfect choice for machining intricate parts requiring simultaneous 5-axis contouring
- Ultra-high accuracies of +/- 0.002mm (+/-0.000079") / full stroke
- Highly rigid, ultra-high precision Roller Gear Cam Table in 4th and 5th axes
- Kitamura's original Icon-drive Arumatik®-Mi CNC delivers super-fast, super-smooth control processing for optimum machining of complex workpieces



Mytrunnion-4G

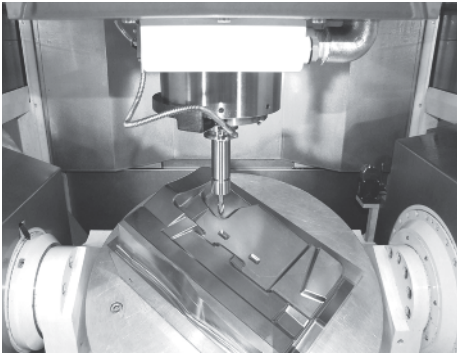

Superior trunnion design and construction assures optimum rigidity for unparalleled precision and long tool life. It also assures maximum stiffness and machining flexibility by allowing the workpiece to be positioned closer to the spindle.



Mytrunnion-7G
Large capacity



Shown with optional 100T ATC



Mytrunnion 5-Axis Machining Centers

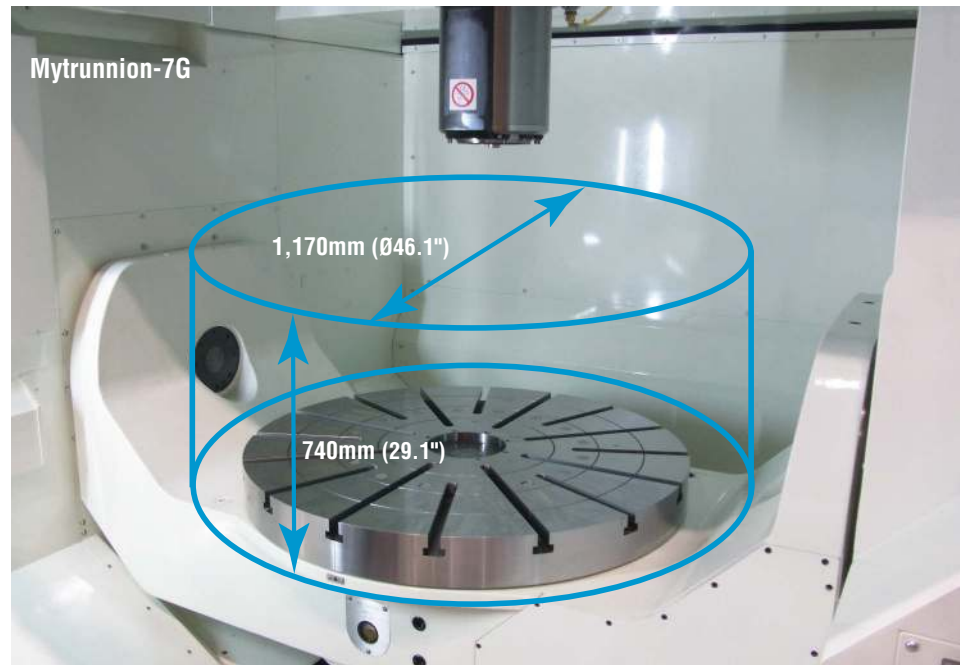
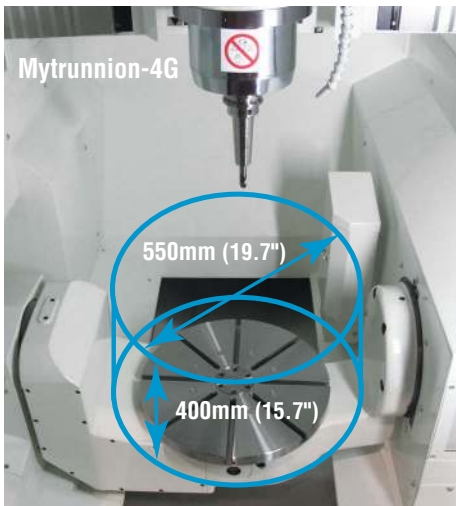

Available in two sizes, the Mytrunnion Series is designed for ultra high-precision simultaneous 5-Axis machining of complex components up to 1,170mm diameter x 740mm height (46.1" x 29.1"). Superior rapid feeds position the spindle and work quickly for unmatched productivity. The trunnion table features "zero-backlash" construction and is driven by an ultra high-precision roller gear cam in 4th & 5th axes. Trunnion design also assures maximum stiffness and flexibility to position the workpiece closer to the spindle. Both models feature 150 degree (-120 to +30 degrees) A-Axis tilting trunnion tables. C-Axis table rotation is 360 degrees with a 0.001 degree minimum indexing command.



Efficient, ultra-high speed tool handling slashes idle time to maximize machining profit. Kitamura Mytrunnion 5-Axis machining centers employ a memory-random tool selection system for smooth idle-free tool changes. Generous 60T (100 opt.) ATC is conveniently located for optimum operator accessibility, offering flexibility in the parts you produce.

SPECIFICATIONS

	Mytrunnion-4G	Mytrunnion-7G
Table		
Table Size	Ø400mm (15.7")	Ø1,000mm (Ø39.4")
T-Slot (Width x Qty.)	12mm (0.47") x 8	22mm (0.87") x 8
Table Indexing	4th & 5th Axes 0.001°	4th & 5th Axes 0.001°
Max. Table Load	200kg (440 lbs)	2,000kg (4,400 lbs)
Max. Workpiece Dia.	Ø550mm (Ø21.7")	Ø1,170mm (Ø46.1")
Max. Workpiece Height	400mm (15.7")	740mm (29.1")
Travels		
X-Axis Travel	610mm (24.0")	1,190mm (46.9")
Y-Axis Travel	610mm (24.0")	1,380mm (54.3")
Z-Axis Travel	500mm (19.7")	765mm (30.1")
A-Axis Travel	150 Degrees (-120 to +30)	150 Degrees (-120 to +30)
C-Axis Travel	0 to 360 Degrees Full 5th Axis	0 to 360 Degrees Full 5th Axis
Distance from Table Surface to Spindle Nose (A=0)	150 to 650mm (5.9" to 25.6")	150 to 915mm (5.9" to 36.0")
Spindle		
Spindle Taper	#40 NST (HSK-A63 Option)	#50 NST (HSK-A100 Opt.)
Spindle Speed	40 ~ 15,000min ⁻¹	35 ~ 12,000min ⁻¹ (8,000min ⁻¹ Opt.)
Maximum Spindle Torque	95.5 N•m (70.4 ft•lbs)	585.9 N•m (432.1 ft•lbs)
Drive Method	Direct Drive	Gear Drive, 4-Step
Spindle Motor	15kW (20HP AC/10 min) 7.5kW (10HP AC/Cont.)	40kw (53 HP AC/15 min.) 22kw (30 HP AC/Cont.)
Feed		
Rapid Feed X, Y	50m/min (1,969ipm)	50m/min (1,969ipm)
Rapid Feed Z	25m/min (985ipm)	30m/min (1,181ipm)
Rapid Feed A	18,000 deg/min (50min ⁻¹)	9,000 deg/min (25min ⁻¹)
Rapid Feed C	18,000 deg/min (50min ⁻¹)	9,900 deg/min (27.5min ⁻¹)
Cutting Feed Rate X, Y, Z	24m/min (945ipm)	30m/min (1,181ipm)
ATC		
Tool Storage Capacity	60 Tools (Opt. 100)	60 Tools (Opt. 100)
Tool Selection Method	Memory Random	Memory Random
Tool Holder Style	CT (BT) 40 (HSK-A63 Option)	CT (BT) 50 (HSK-A100 Option)
Maximum Tool Size (Dia. x Length) If Adjacent Tool Pot is Empty	Ø75 x 300mm (Ø3.0 x 11.8") Ø150 x 300mm (Ø5.9 x 11.8")	Ø125 x 450mm (Ø4.9" x 17.7") Ø240 x 450mm (Ø9.4" x 17.7")
Max. Tool Weight	10kg (22 lbs.)	25kg (55 lbs.)
Tool to Tool	2.2 seconds	3.3 seconds
Chip to Chip	5.8 seconds, min.	9.7 seconds, min.
Utilities		
Power Requirement	45KVA, 200v AC, 3 Phase	65KVA, 200v AC, 3 Phase
Air Requirement	0.5 MPa, 350L/min (90psi, 13cfm)	0.5MPa, 400L/min (90 psi, 15 cfm)
Machine Dimensions		
Required Space (W x L)	2,421 x 3,706mm (95.3" x 145.9")	4,072 x 6,728mm (160.3" x 264.9")
Machine Height	2,850mm (112.2")	4,169mm (164.1")
Pallet Table Height	750mm (29.5")	1,110mm (43.7")
Machine Net Weight	9,100kg (20,020 lbs.)	33,000kg (72,600 lbs.)
Control		
	Arumatik®-Mi Control	Arumatik®-Mi Control

Specifications subject to change without notice.



OPTIONS

Flexibility to produce parts with optimum efficiency and precision . . .

Expand machining capability with a wide variety of optional accessories to meet your exacting machining requirements.

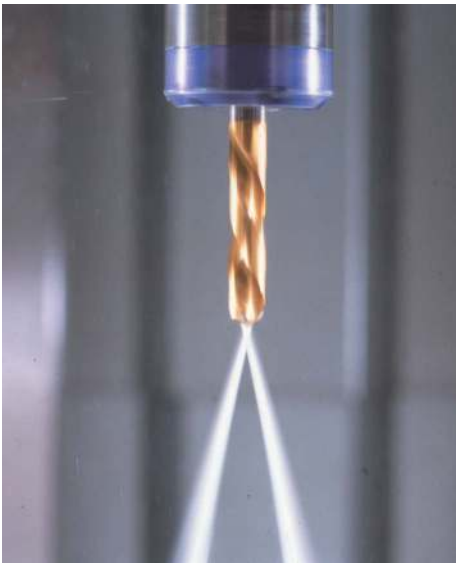

Coolant Through Spindle

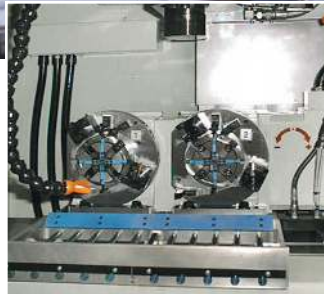
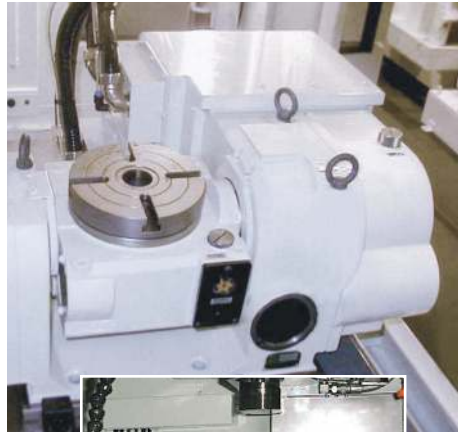

Field Retrofittable 4th and 5th Axis Rotary Tables

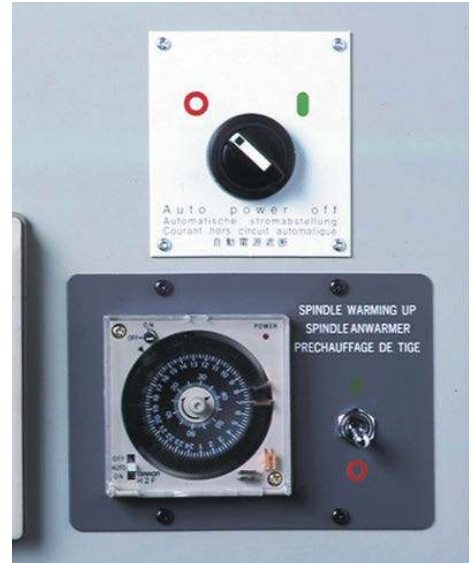

Auto Power Off Device and Spindle Warm-Up Timer



Spindle Air Blow System



Robotics / Automation



Machine Tool Probes and Software



High Capacity, Double-Decker Chip Conveyor

Primary conveyor removes all chip types and sizes including strings and balls.

Lower drag-type separator conveyor removes fines that are passed through or carried back into the system by the primary conveyor

Permanent self-cleaning media drum separates fines from the coolant to 100 micro nominal

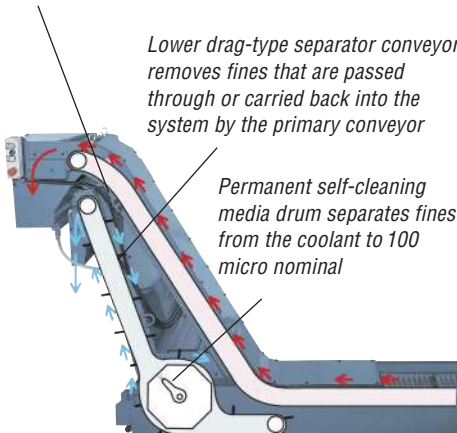

Spindle Probe



Contact Tool Setting Probe



Non-Contact Laser Tool Probe



MYCENTER-3XG / 3XiG

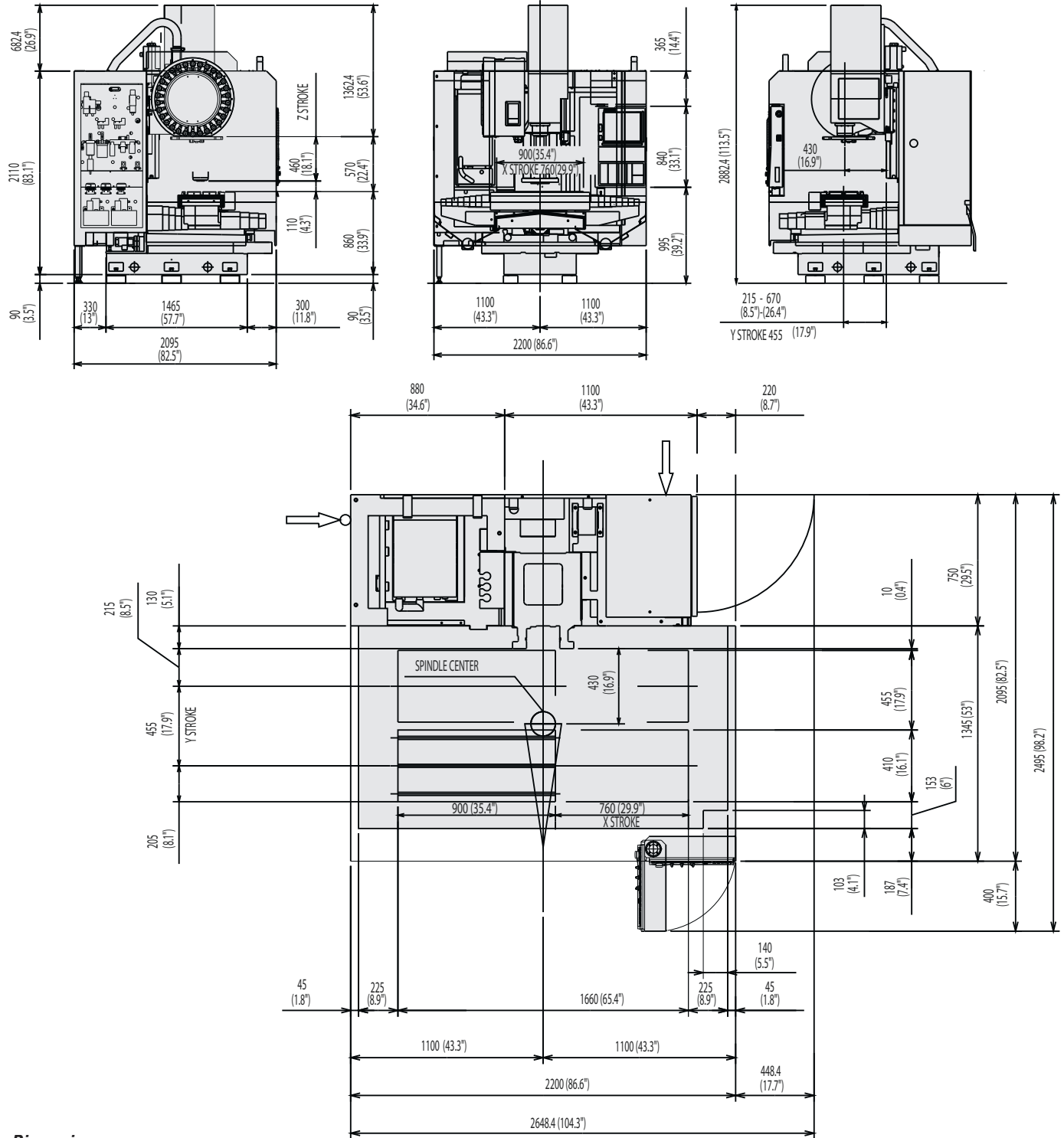

Move-In Dimensions

Required Space W x D:	2,200 x 2,095mm (86.6" x 82.5")
Machine Height:	2,343mm (92.2")
Machine Net Weight:	5,520kg (12,144Lbs)
Power Requirement:	30KVA

Specifications subject to change without notice.

MYCENTER-3XG/3XiG SPARKCHANGER

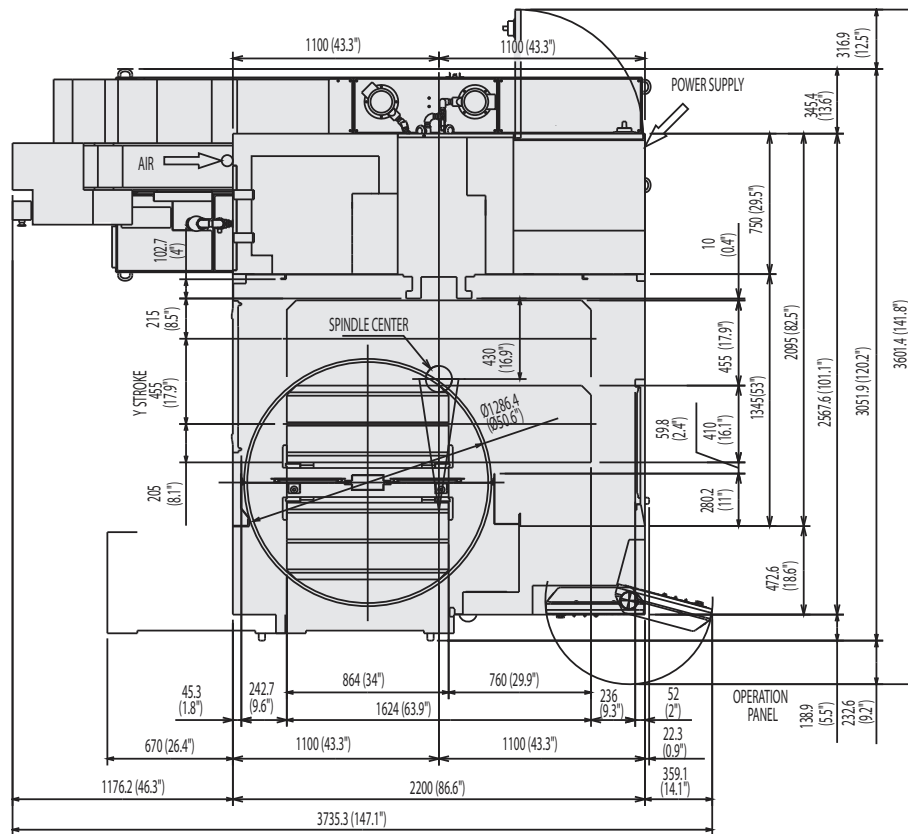
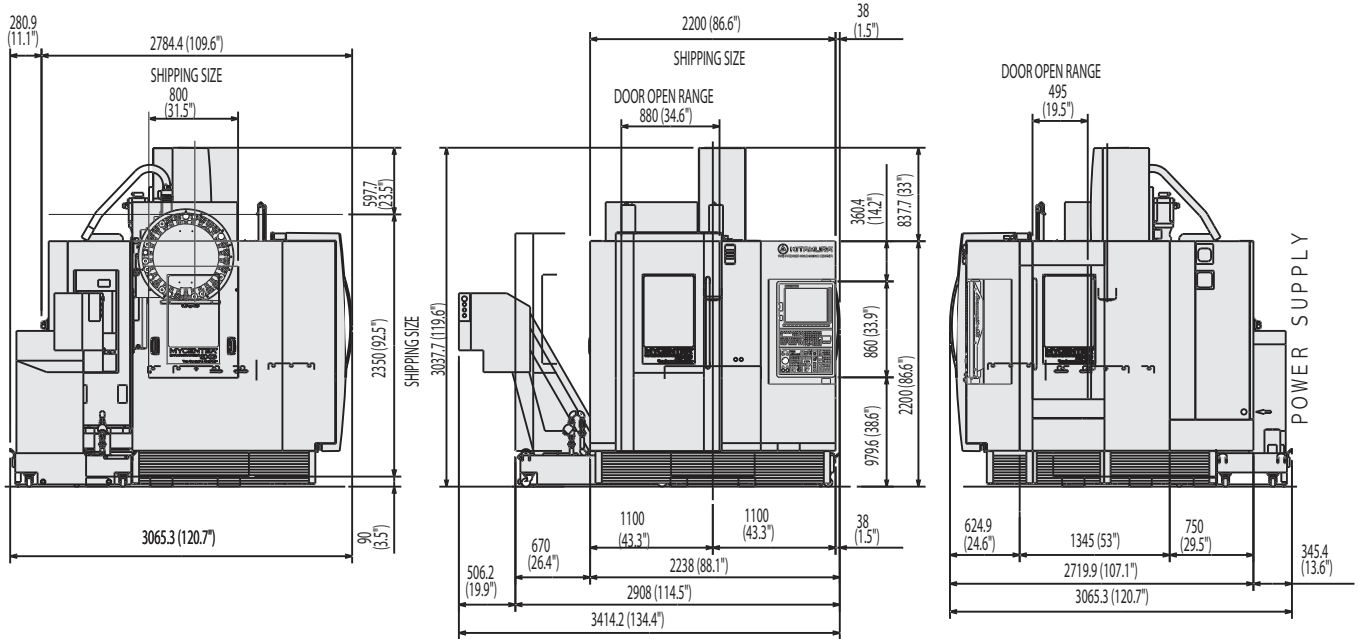

Move-In Dimensions

Required Space W x D:	2,200 x 2,785mm (86.6" x 109.6")
Machine Height:	2,350mm (92.5")
Machine Net Weight:	7,320kg (16,104Lbs)
Power Requirement:	30KVA

Specifications subject to change without notice.



BRIDGECENTER-6G 50 TAPER

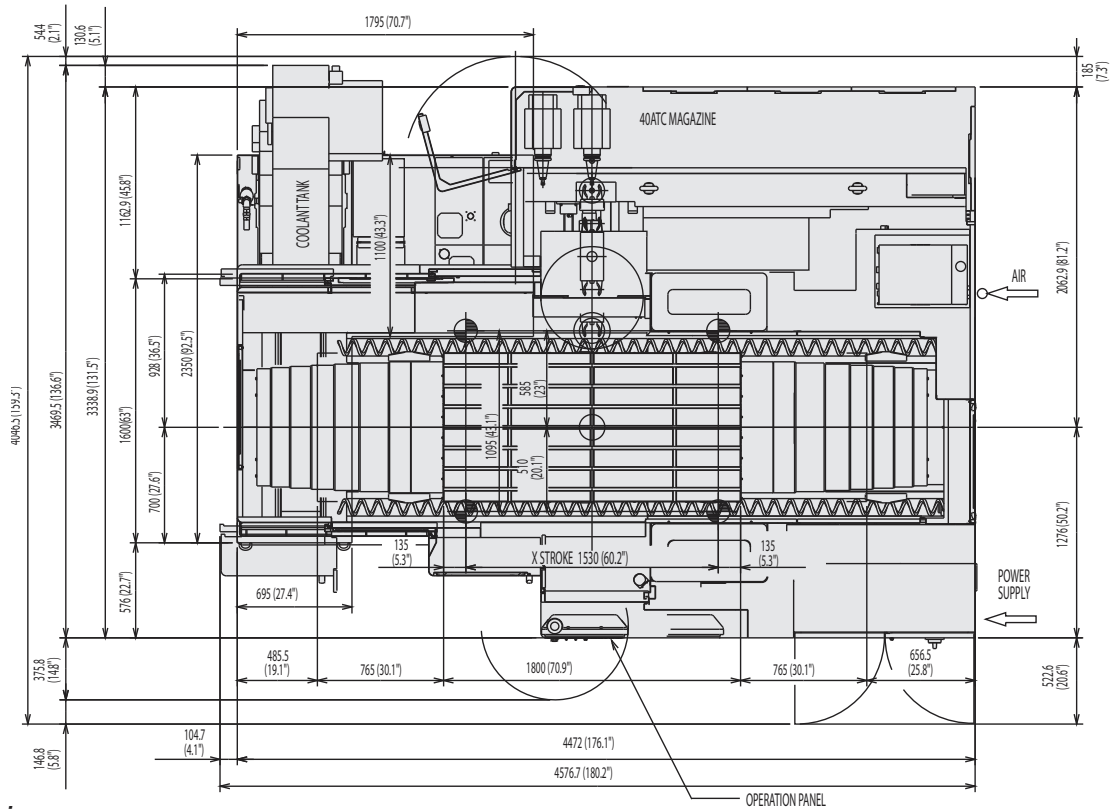
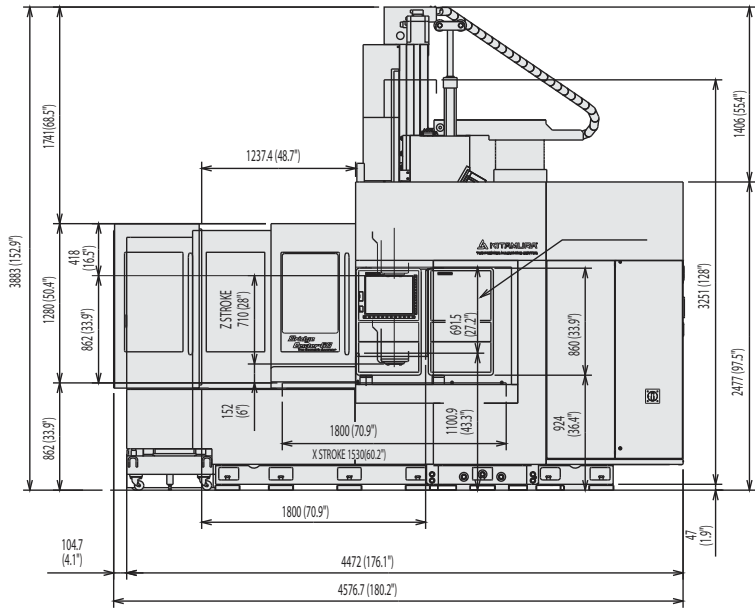
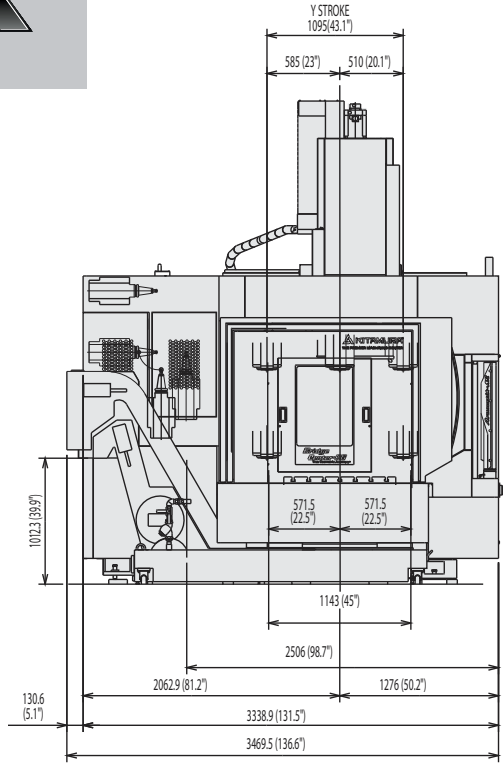

Move-In Dimensions

Required Space W x D:	2,571 x 4,472mm (101.2" x 176.1")
Machine Height:	3,251mm (128.0")
Machine Net Weight:	17,500kg (38,500Lbs)
Power Requirement:	35/45KVA (#40 / #50)

Also available in #40 taper

Specifications subject to change without notice.

BRIDGECENTER-8G 50 TAPER

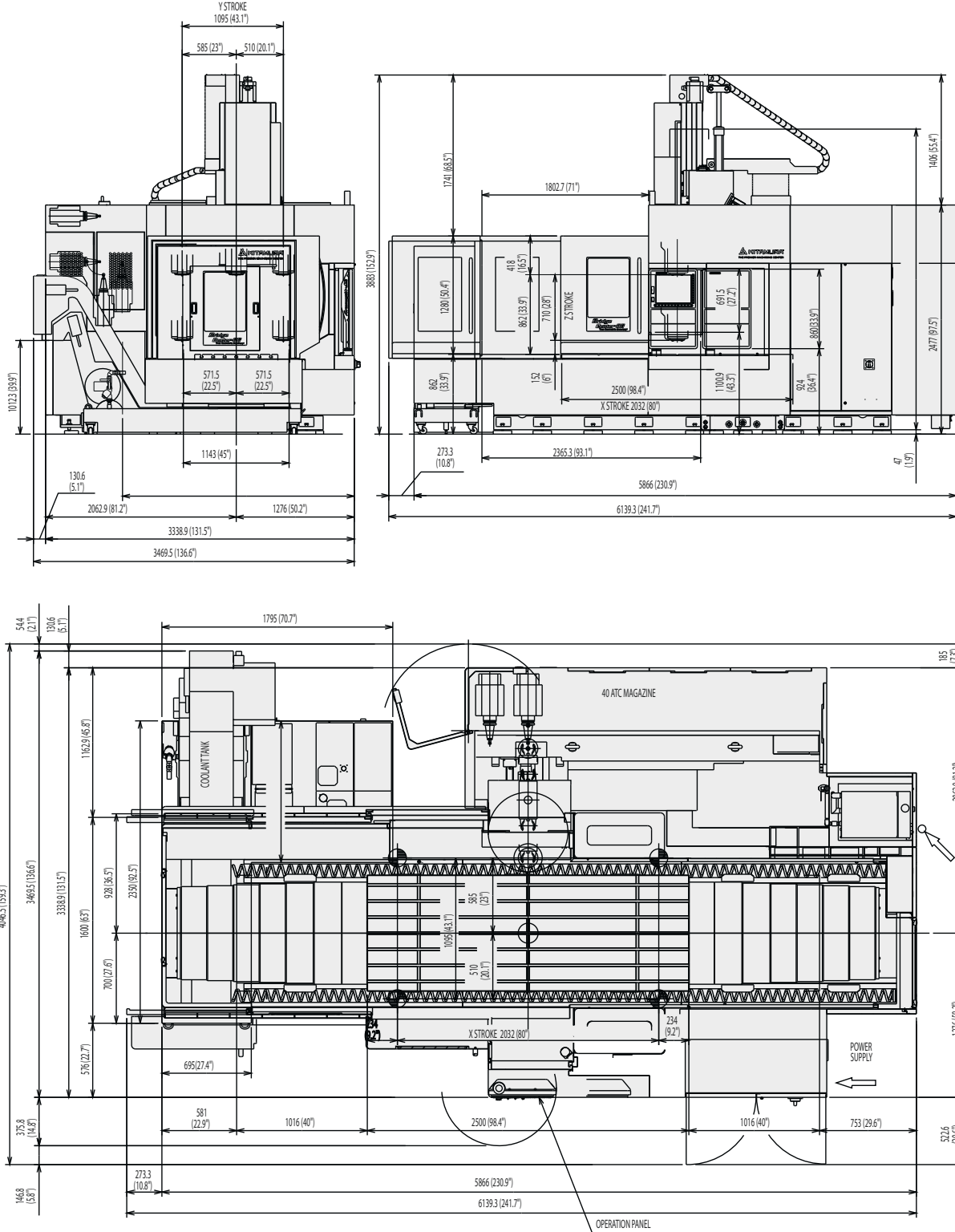

Move-In Dimensions

Required Space W x D: 2,571 x 5,866mm (101.2" x 230.9")

Machine Height: 3,251mm (128")

Machine Net Weight: 20,000kg (44,000Lbs)

Power Requirement: 45KVA

Also available in #40 taper

Specifications subject to change without notice.



BRIDGECENTER-10G

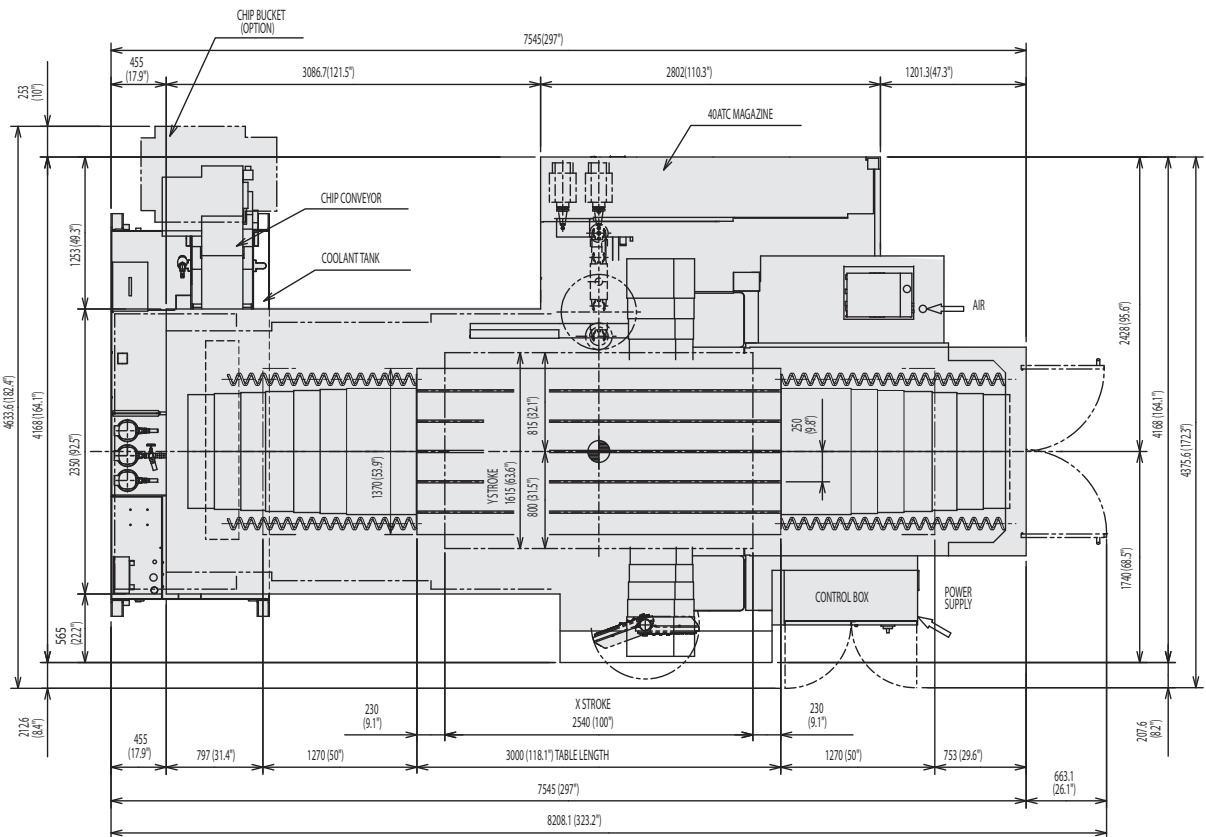
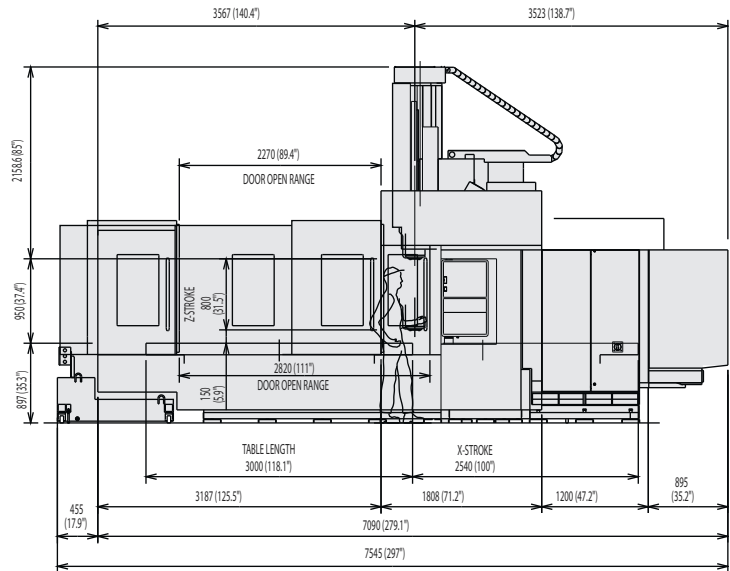
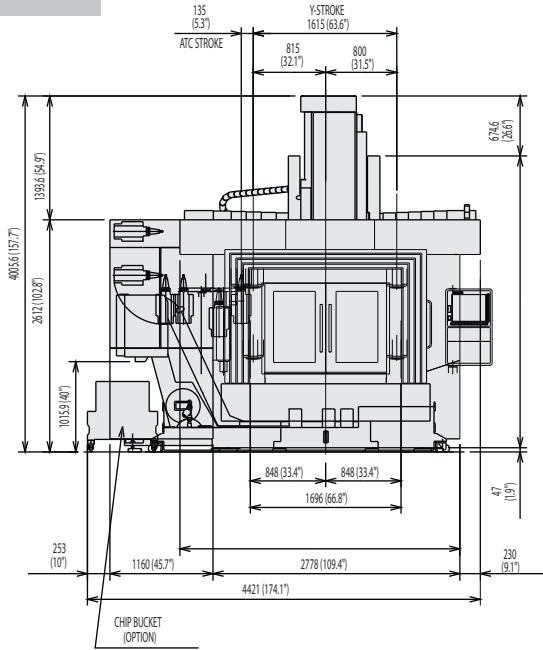

Move-In Dimensions

Required Space W x D: 2,948 x 7,205mm (116.1" x 283.7")

Machine Height: 3,284mm (129.3")

Machine Net Weight: 28,000kg (61,600Lbs)

Power Requirement: 50KVA

Specifications subject to change without notice.

BRIDGECENTER-12G

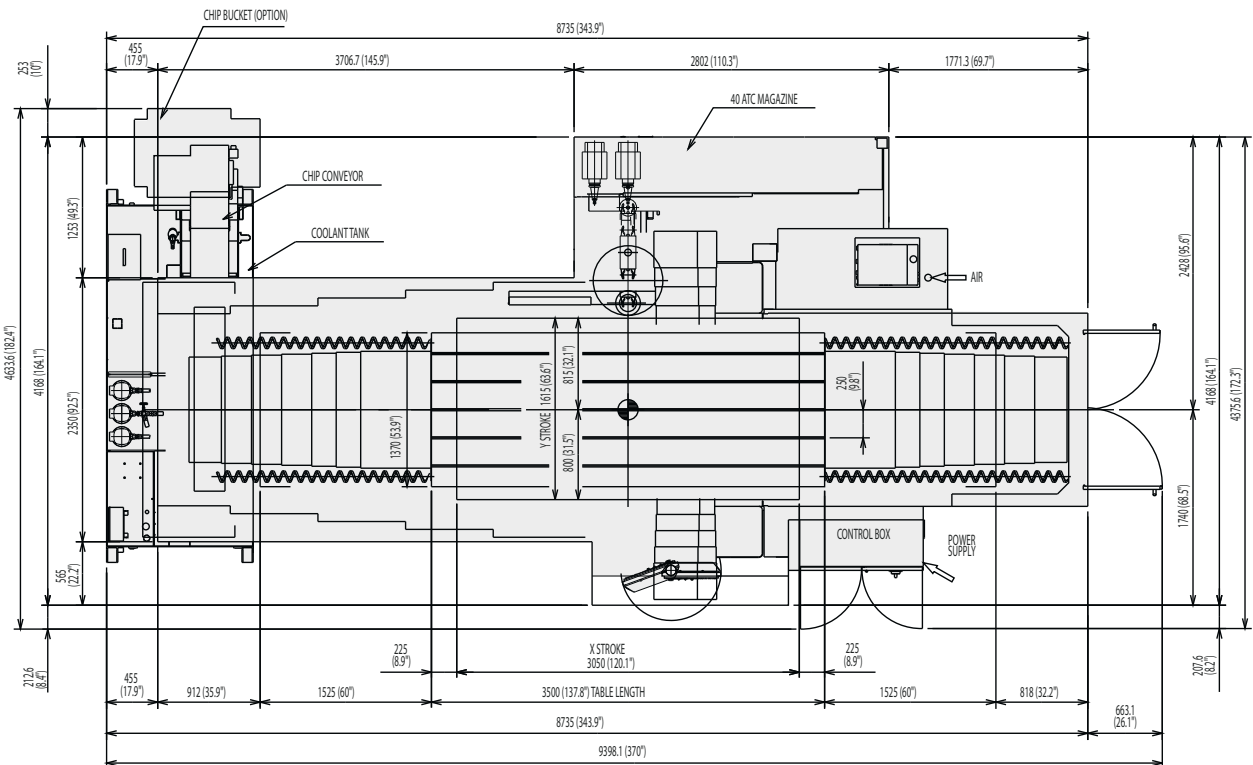
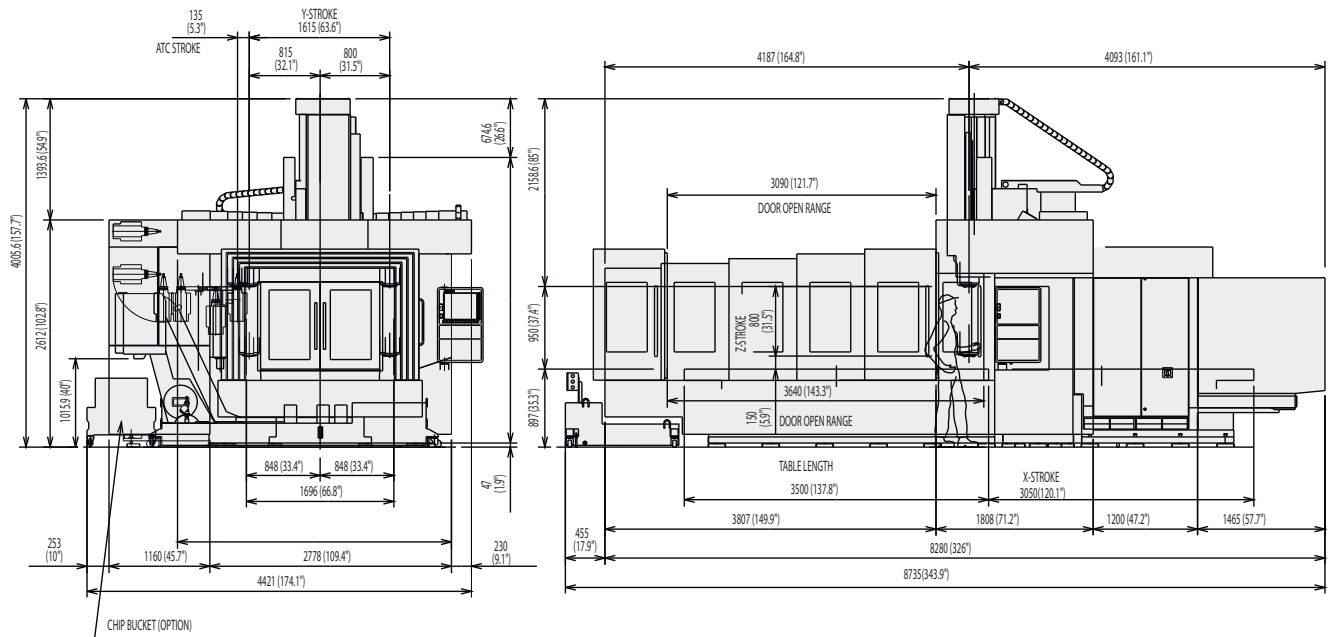

Move-In Dimensions

Required Space W x D: 2,948 x 8,345mm (116.1" x 328.5")

Machine Height: 3,284mm (129.3")

Machine Net Weight: 31,000kg (68,200Lbs)

Power Requirement: 50KVA

Specifications subject to change without notice.



MYTRUNNION-4G

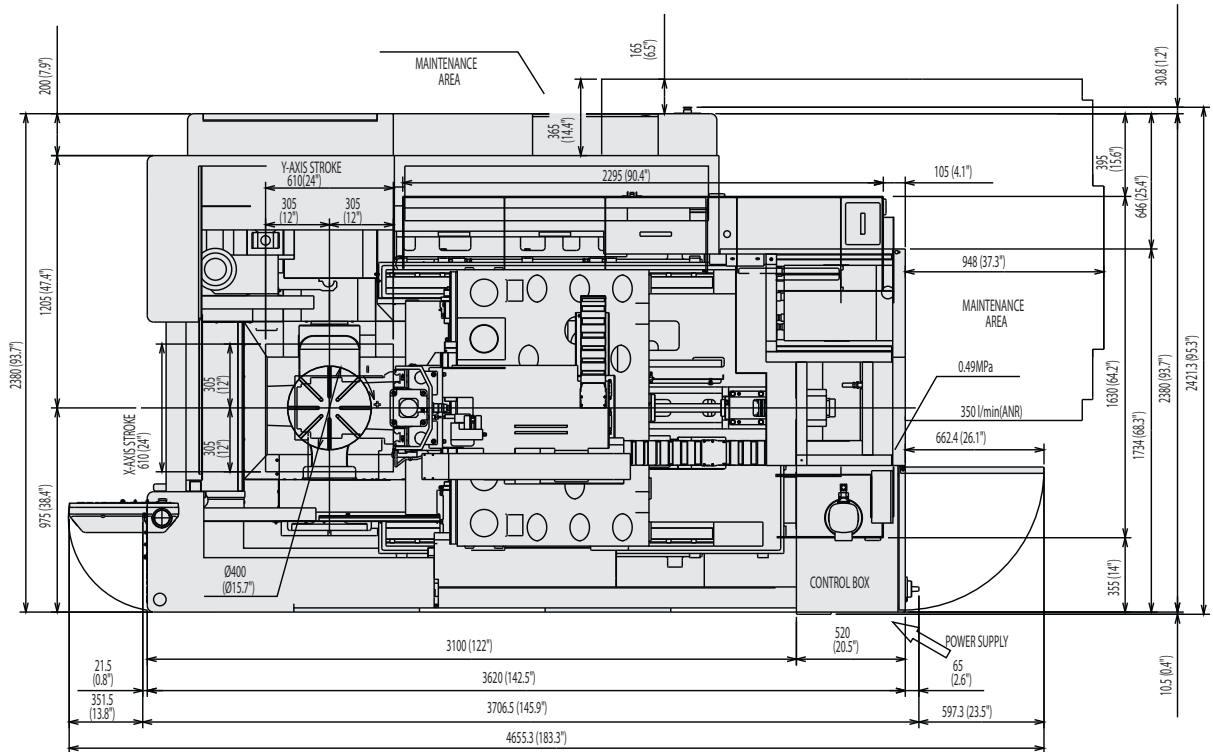
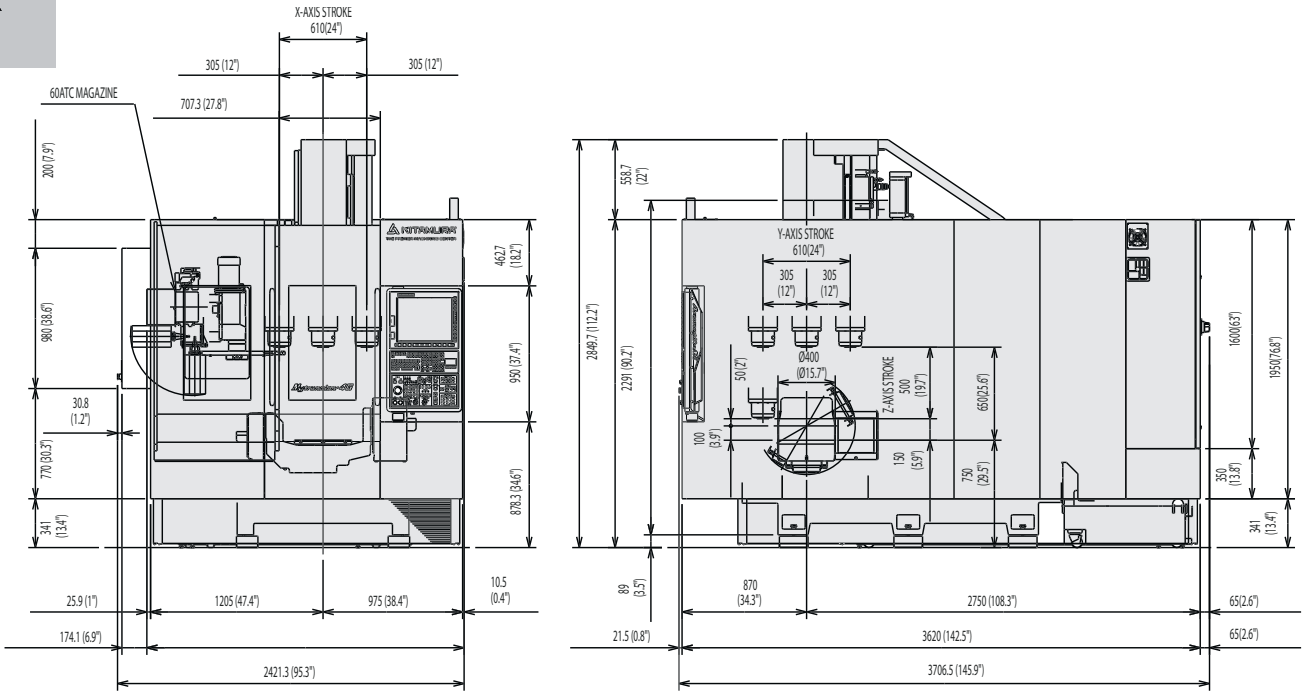

Move-In Dimensions

Required Space W x D: 2,216 x 3,707mm (87.2" x 145.9")

Machine Height: 2,337mm (92.0")

Machine Net Weight: 9,100kg (20,020Lbs)

Power Requirement: 45KVA

MYTRUNNION-7G

Shown with optional 100T ATC

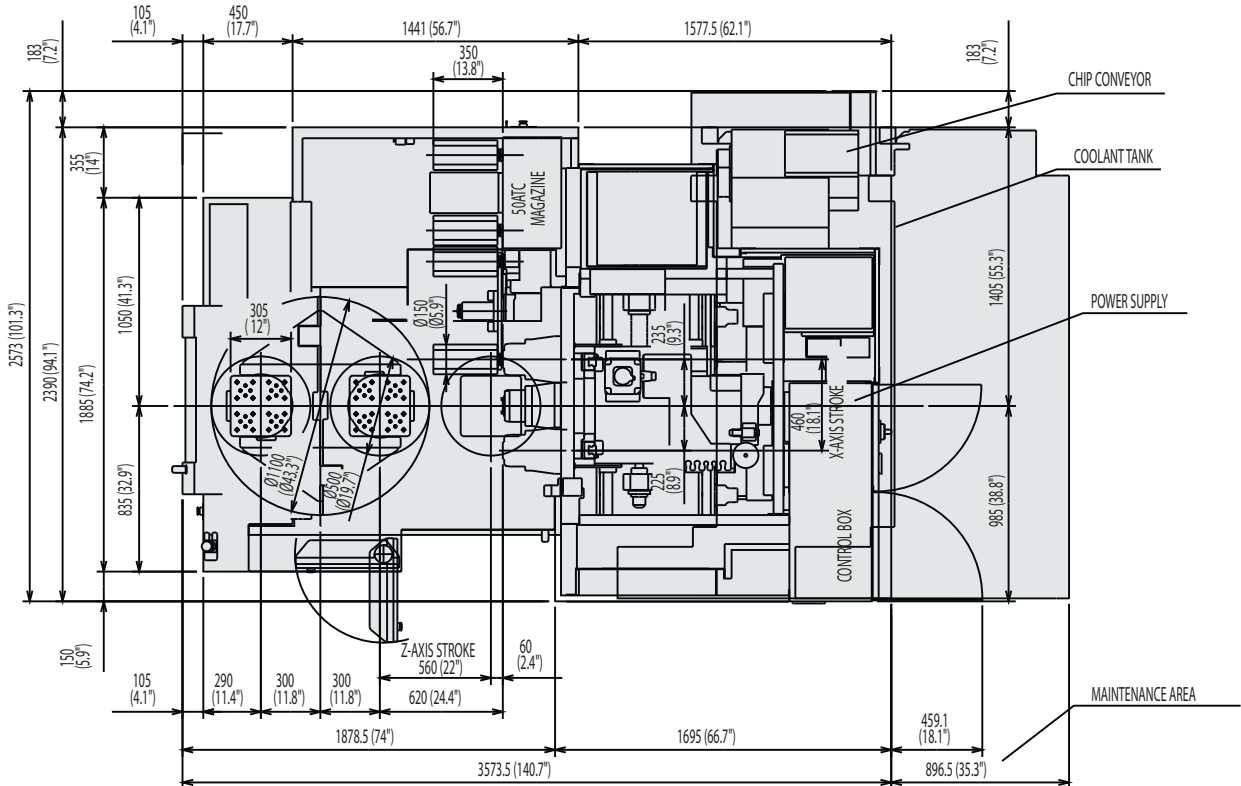
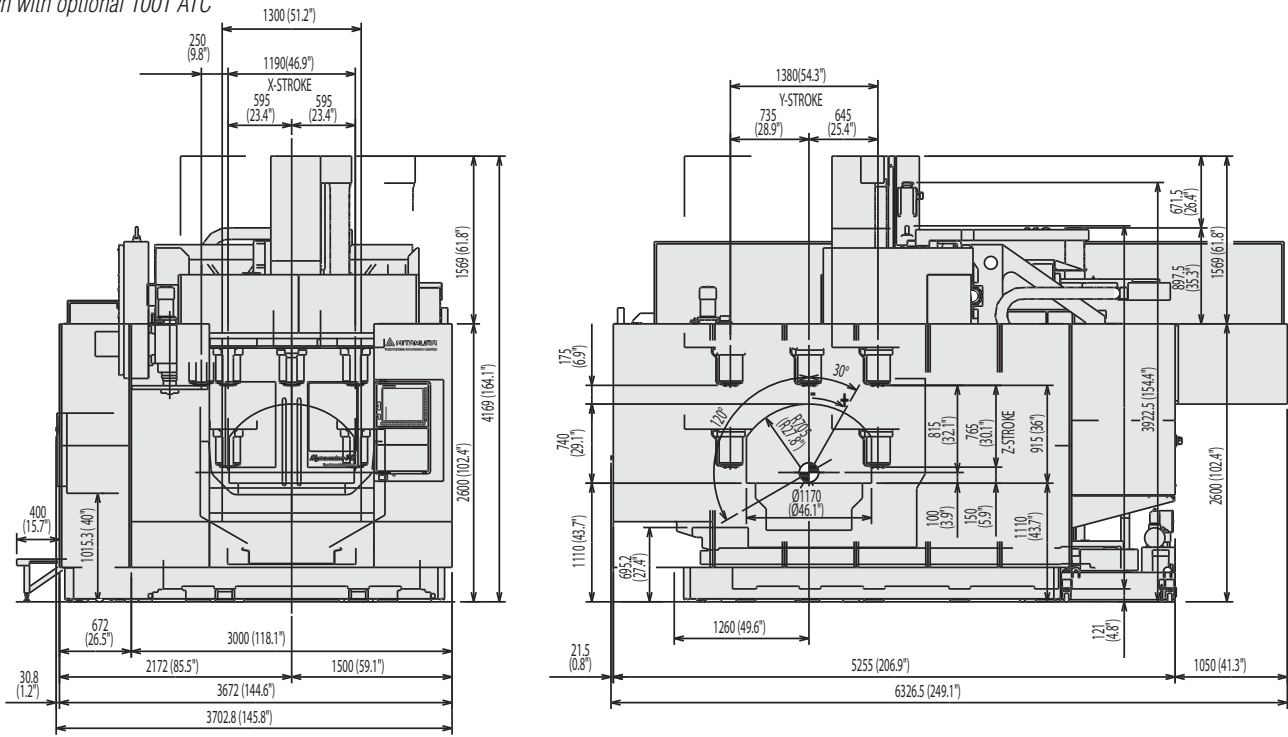

Move-In Dimensions

Required Space W x D:	3,000 x 5,255mm (118.1" x 206.9")
Machine Height:	3,396mm (133.7")
Machine Net Weight:	33,000kg (72,600Lbs)
Power Requirement:	65KVA

Specifications subject to change without notice.



■ Kitamura GmbH
Düsseldorf,
Germany

HEADQUARTERS
Takaoka City,
Toyama Pref.,
Japan 



US CORPORATE
HEADQUARTERS
Wheeling, IL



KITAMURA® MACHINERY CO., LTD.

Kitamura Machinery Co., Ltd. (Headquarters)
1870-Toide, Takaoka-City, Toyama Pref., Japan
TEL: (0766) 63-1100 FAX: (0766) 63-1128
www.kitamura-machinery.co.jp
E-mail: mycenter@kitamura-machinery.co.jp

Kitamura Machinery of U.S.A., Inc. (Chicago)
78 East Century Drive, Wheeling, Illinois 60090 U.S.A.
TEL: (847) 520-7755 FAX: (847) 520-7763
www.kitamura-machinery.com
E-mail: info@kitamura-machinery.com

Kitamura Machinery GmbH (Düsseldorf)
Wahlerstrasse 39, 40472 Düsseldorf, Germany
TEL: (0211) 65-6077 FAX: (0211) 904-7916
www.kitamura-machinery.eu
Email: info@kitamura-machinery.eu

