

Renishaw vision fixtures

Your single source for metrology fixturing

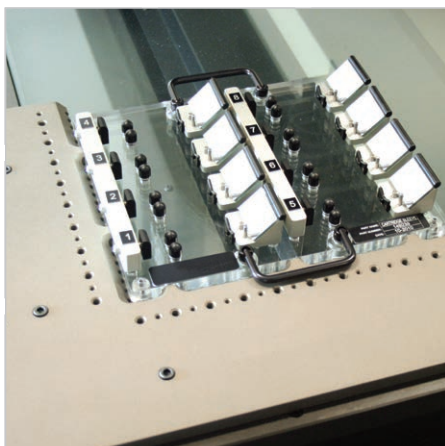
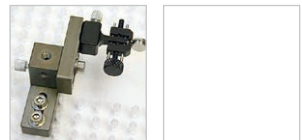
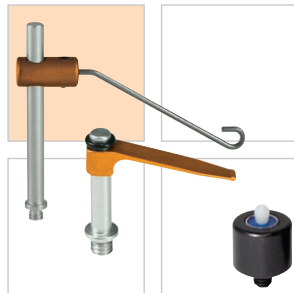
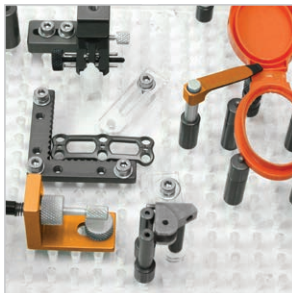
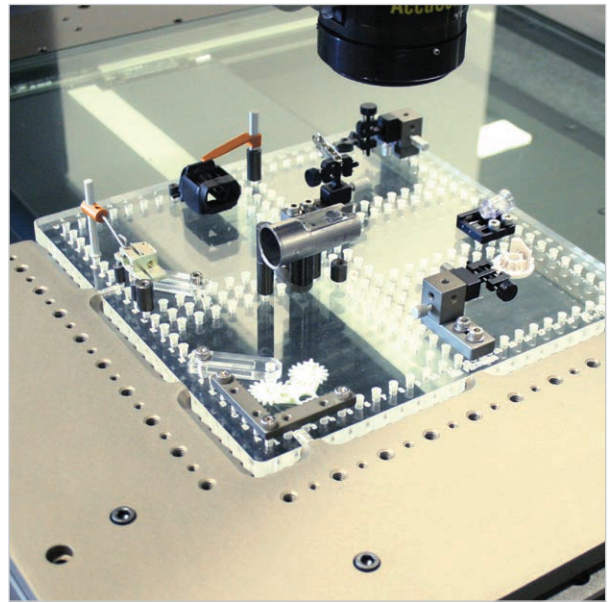
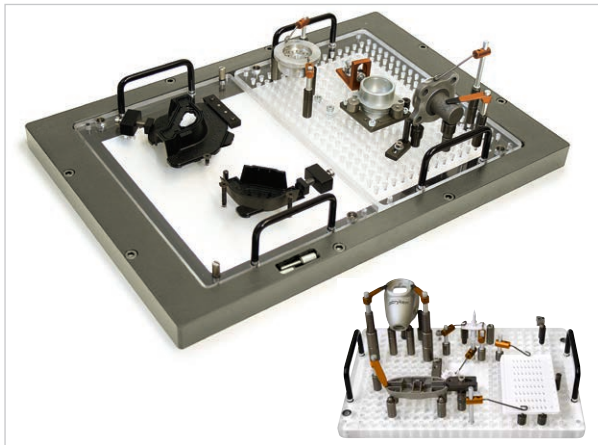

This page is intentionally left blank.

Contents

Section 1	Introduction
Section 2	Quick load corner
Section 3	QLC fixturing kits
Section 4	M4 kits
Section 5	M6 kits
Section 6	Plates
Section 7	Interchangeable vision fixture
Sections 8–15	Vision components
Section 16	Custom fixtures

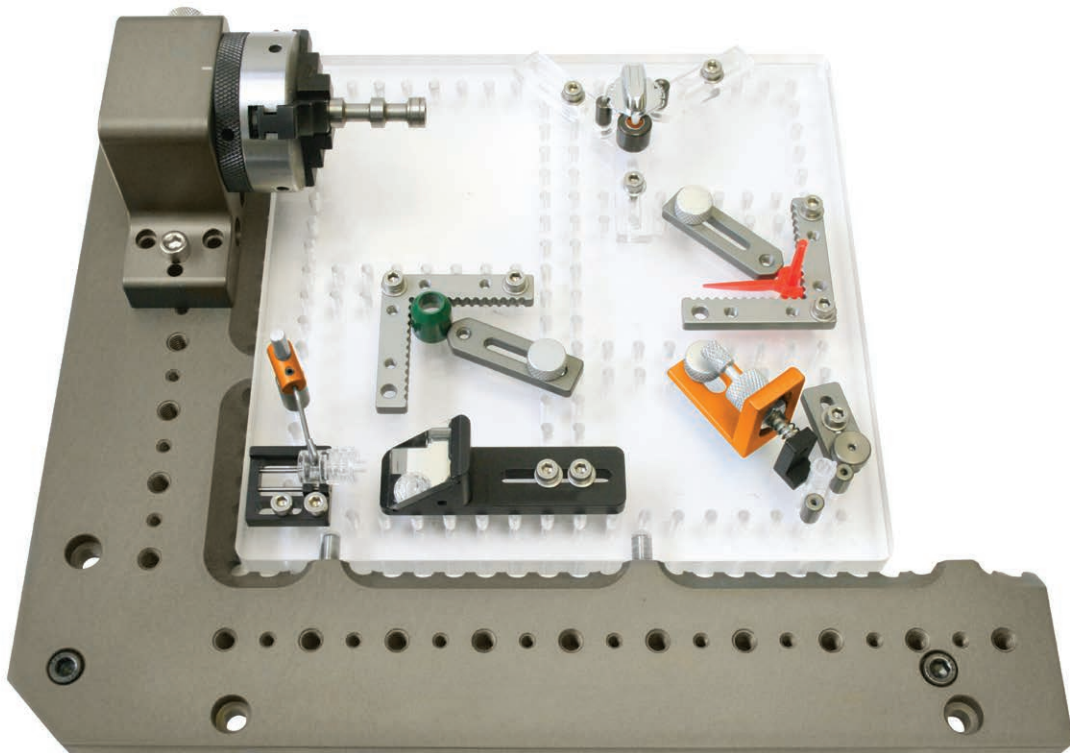

Introduction

1.1

Modular fixturing for your vision system

Renishaw vision fixtures are designed for use with vision systems or multi-sensor machines, creating a fast and repeatable way to fixture your part for consistent and accurate inspection.

Each vision fixture is made with a precision acrylic base plate that allows for backlighting and a clear, clean view of the part. Fixturing components can quickly be threaded into the base plate and arranged in any configuration, allowing the part to be held in a virtually free state with very little force applied to the surface. The part can be viewed easily without obstruction to the backlight or probe path. Fixturing components can be placed within a tight circumference to hold and locate the smallest of parts.

Renishaw offers two fixturing options to fit your specific vision machine:

- **Quick load corner (QLC)**
designed to fit your specific vision machine
- **Interchangeable vision fixture (IVF)**
for vision systems 450 mm × 450 mm or larger, customised for your machine and application

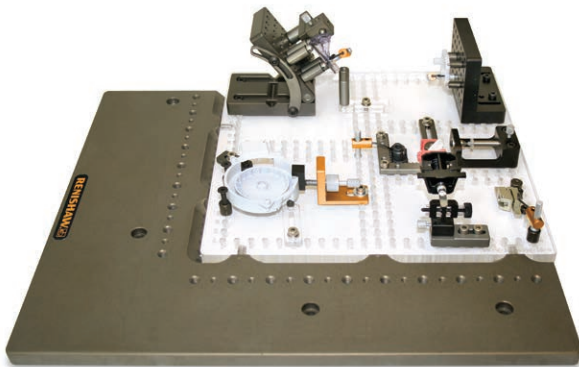

Quick load corner

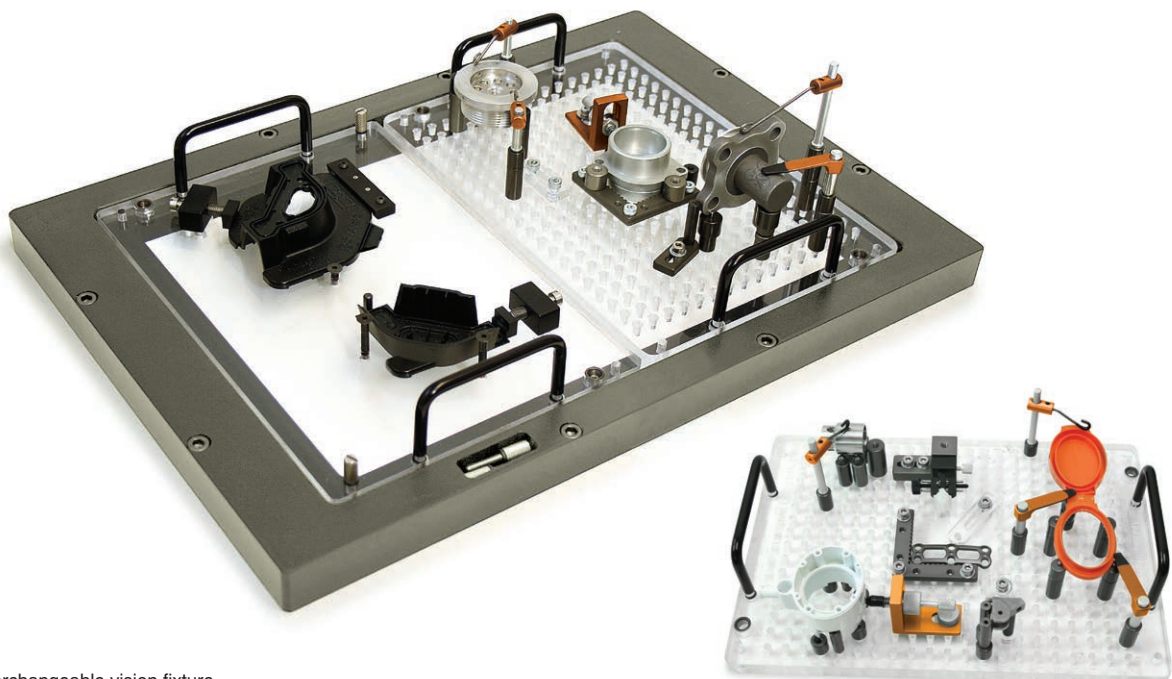

Interchangeable vision fixture

Quick load corner

Quick load corner (QLC)

Renishaw's quick load corner (QLC) system is designed to fit your specific vision machine.

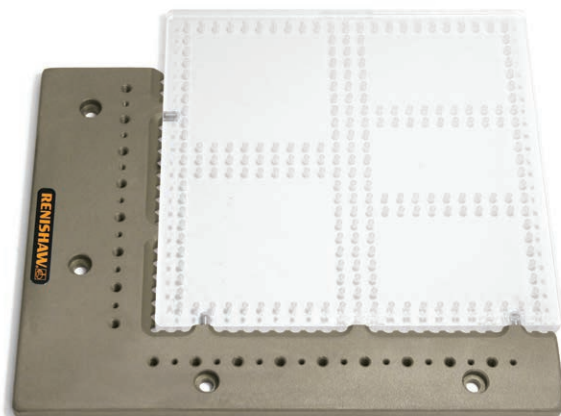

QLC with multi-window plate

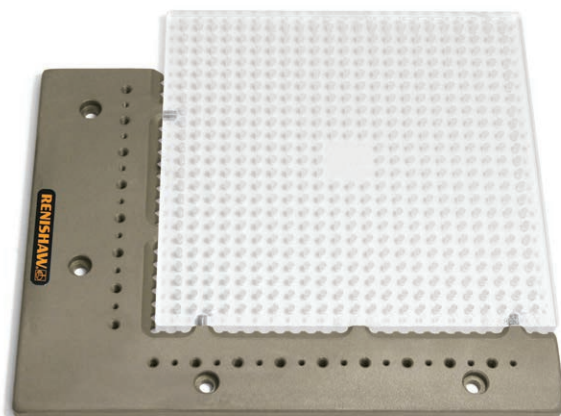

QLC with multi-hole plate

This system is made to fit the lower left hand corner of your vision stage and the location of its mounting holes.

The quick load corner contains magnets that enable Renishaw's vision acrylic base plates to snap into a precise and repeatable position, enabling quick and easy loading and unloading of plates.

Steel pins are pressed into the sides of the plate to fit the magnets contained in the QLC.

The edges of the QLC are serrated so that parts can be mounted directly against them and fixed with Renishaw M4 or M6 fixturing components. This enables quick and easy viewing and inspection.

There are two plate options to choose from:

- **Multi-hole**
Set up and check as many parts as possible at one time with a clear area in the centre of the plate with no holes.
- **Multi-window**
More windows for the clearest view of small parts.

Additional sub plates may be purchased for fixturing more parts.

Mounting holes are provided for most major brands of vision systems. To ensure you receive the correct size and proper fit, include your machine make and model number when ordering.

QLC vision fixturing kits

3.1

Choosing your fixturing kit

Renishaw vision fixtures are sold in preconfigured kits to make it easy to get started. A kit consists of one acrylic base plate, a quick load corner (QLC) and a comprehensive set of components.

The kit to choose will depend on the type of parts you are going to fixture.

Renishaw offers two kit choices:

- **Multi-hole:** more holes for attaching more components
- **Multi-window:** more windows for optimal viewing of small parts

Kits are available in M4 or M6.

The QLC frame is fitted to your specific vision system. Contact your local sales office stating your machine make and model number to determine which frame you require.

Individual components may also be purchased to expand your fixturing kit.

How to choose your kit

- 1 Choose a thread size: M4 or M6
- 2 Contact your local sales office to select the correct QLC frame
- 3 Choose a plate type: multi-hole or multi-window
- 4 Choose a set of components



QLC M4 vision kits

The QLC M4 vision kit is ideal for parts that fit within a 75 mm × 75 mm working volume.

A kit includes an acrylic base plate with M4 threaded holes 10 mm on centre, a quick load corner and one set of components (A or B).



R-QLC1-PV2-B-4 kit

NOTE: Each QLC frame is specific to your machine. Please contact your local sales office to determine which frame you need.

Plate sizes multi-hole set A

Kit part no.	Base plate size
R-QLC-PV1-A-4	13 mm × 150 mm × 150 mm
R-QLC-PV2-A-4	13 mm × 200 mm × 200 mm
R-QLC-PV3-A-4	13 mm × 250 mm × 150 mm
R-QLC-PV4-A-4	13 mm × 250 mm × 250 mm

Plate sizes multi-window set A

Kit part no.	Base plate size
R-QLC-PVW1-A-4	13 mm × 200 mm × 200 mm
R-QLC-PVW2-A-4	13 mm × 250 mm × 150 mm
R-QLC-PVW3-A-4	13 mm × 250 mm × 250 mm
R-QLC-PVW4-A-4	13 mm × 400 mm × 400 mm

Plate sizes multi-hole set B

Kit part no.	Base plate size
R-QLC-PV1-B-4	13 mm × 150 mm × 150 mm
R-QLC-PV2-B-4	13 mm × 200 mm × 200 mm
R-QLC-PV3-B-4	13 mm × 250 mm × 150 mm
R-QLC-PV4-B-4	13 mm × 250 mm × 250 mm

Plate sizes multi-window set B

Kit part no.	Base plate size
R-QLC-PVW1-B-4	13 mm × 200 mm × 200 mm
R-QLC-PVW2-B-4	13 mm × 250 mm × 150 mm
R-QLC-PVW3-B-4	13 mm × 250 mm × 250 mm
R-QLC-PVW4-B-4	13 mm × 400 mm × 400 mm

Component set A (part no. R-FSV-A-4)

Qty	Part no.	Description
3	R-S-610-4	6 mm dia. × 10 mm standoff
3	R-S-625-4	6 mm dia. × 25 mm standoff
3	R-S-95-4	9 mm dia. × 5 mm standoff
3	R-S-910-4	9 mm dia. × 10 mm standoff
3	R-S-920-4	9 mm dia. × 20 mm standoff
3	R-S-925-4	9 mm dia. × 25 mm standoff
3	R-S-1210-4	12 mm dia. × 10 mm standoff
3	R-S-1225-4	12 mm dia. × 25 mm standoff
2	R-SP-610-4	6 mm dia. × 10 mm pin standoff
2	R-SP-910-4	9 mm dia. × 10 mm pin standoff
2	R-CTT-40-25-4	40 mm tension clamp with coated soft tip, 25 mm post
2	R-CWT-25-25-4	25 mm wire clamp with coated soft tip, 25 mm post
2	R-CWT-50-50-4	50 mm wire clamp with coated soft tip, 50 mm post
1	R-CP-4	Pusher clamp
1	R-CVM-B-4	Micro-clamp vice with base
1	R-CSPS-1210-4	Spring pusher standoff clamp
4	R-RPA-4	Aluminium resting pin
1	R-VC-5050-4	50 mm × 50 mm corner viewer
1	R-AJ-9-4	9 mm dia. adjustable jackstand
1	R-AS-30-4	30 mm long adjustable slide
1	R-ASA-45-4	45 mm long adjustable acrylic slide base
1	R-TB-1619-4	Tower block with base 16 mm ² × 19 mm
1	R-TC-300190-4	300 mm × 190 mm × 25 mm component tray
1	R-BC10	50 mm × 200 mm × 150 mm compartment box (not shown)

Total: 48

Component set B (part no. R-FSV-B-4)

Qty	Part no.	Description
3	R-S-65-4*	6 mm dia. × 5 mm standoff
6	R-S-610-4	6 mm dia. × 25 mm standoff
6	R-S-625-4	6 mm dia. × 25 mm standoff
3	R-S-95-4	9 mm dia. × 5 mm standoff
6	R-S-910-4	9 mm dia. × 10 mm standoff
6	R-S-920-4	9 mm dia. × 20 mm standoff
6	R-S-925-4	9 mm dia. × 25 mm standoff
6	R-S-1210-4	12 mm dia. × 10 mm standoff
6	R-S-1225-4	12 mm dia. × 25 mm standoff
4	R-SP-610-4	6 mm dia. × 10 mm pin standoff
4	R-SP-910-4	9 mm dia. × 10 mm pin standoff
4	R-CTT-40-25-4	40 mm tension clamp with coated soft tip, 25 mm post
4	R-CWT-25-25-4	25 mm wire clamp with coated soft tip, 25 mm post
4	R-CWT-50-50-4	50 mm wire clamp with coated soft tip, 50 mm post
4	R-CP-4	Pusher clamp
1	R-CVM-B-4	Micro-clamp vice with base
1	R-CSPS-1210-4	Spring pusher standoff clamp
4	R-RPA-4	Aluminium resting pin
1	R-VC-5050-4	50 mm × 50 mm corner viewer
2	R-AJ-9-4	9 mm dia. adjustable jackstand
2	R-AS-30-4	30 mm long adjustable slide
2	R-ASA-45-4	45 mm long adjustable acrylic slide base
1	R-TB-1619-4	Tower block with base 16 mm ² × 19 mm
1	R-TC-300190-4	300 mm × 190 mm × 25 mm component tray
1	R-BC10	50 mm × 200 mm × 150 mm compartment box (not shown)

Total: 85

* = does not have a threaded top

QLC M6 vision kits

5.1

The QLC M6 vision kit is a comprehensive kit for holding plastic, aluminium, rubber and other non-ferrous parts.

A kit includes an acrylic base plate with M6 threaded holes 12.5 mm on centre, a quick load corner and one set of components (A).



R-QLC1-PV2-A-6 kit

NOTE: Each QLC frame is specific to your machine. Please contact your local sales office to determine which frame you need.

Plate sizes multi-hole set A

Kit part no.	Base plate size
R-QLC1-PV1-A-6	13 mm × 150 mm × 150 mm
R-QLC1-PV2-A-6	13 mm × 250 mm × 250 mm

Plate sizes multi-window set A

Kit part no.	Base plate size
R-QLC1-PVW1-A-6	13 mm × 250 mm × 250 mm
R-QLC1-PVW2-A-6	13 mm × 400 mm × 400 mm

Component set A (part no. R-FSV-A-6)

Qty	Part no.	Description
3	R-S-610-6*	6 mm dia. × 10 mm standoff
3	R-S-625-6*	6 mm dia. × 25 mm standoff
3	R-S-95-6*	9 mm dia. × 5 mm standoff
3	R-S-910-6	9 mm dia. × 10 mm standoff
3	R-S-920-6	9 mm dia. × 20 mm standoff
3	R-S-925-6	9 mm dia. × 25 mm standoff
3	R-S-1310-6	13 mm dia. × 10 mm standoff
3	R-S-1320-6	13 mm dia. × 20 mm standoff
2	R-SP-610-6	6 mm dia. × 10 mm pin standoff
2	R-SP-910-6	9 mm dia. × 10 mm pin standoff
4	R-CTT-40-30-6	40 mm tension clamp with coated soft tip, 30 mm post
4	R-CWT-25-25-6	25 mm wire clamp with coated soft tip, 25 mm post
4	R-CWT-50-50-6	50 mm wire clamp with coated soft tip, 50 mm post
1	R-CP-6	Pusher clamp
1	R-CVM-B-6	Micro-clamp vice with base
1	R-CSPS-1925-6	19 mm dia. × 25 mm spring pusher standoff clamp
4	R-RPS-6	Steel resting pin
1	R-VC-7575-6	75 mm × 75 mm corner viewer
1	R-AJ-13-6	13 mm dia. adjustable jackstand
1	R-AS-45-6	45 mm long adjustable slide
1	R-ASA-45-6	45 mm long adjustable acrylic slide base
1	R-TB-2025-6	Tower block with base 20 mm ² × 30 mm
1	R-TC-300190-6	300 mm × 190 mm × 25 mm component tray
1	R-BC10	50 mm × 200 mm × 150 mm compartment box (not shown)

Total: 54

Plates



Vision plates

Acrylic base plates with dowel pins.

Multi-hole plate



R-PV-13200200-10-4

Multi-window plate



R-PV-W-13200200-10-4

Part no.	Thread	Height	Width	Depth	Windows	Hole spacing (OC*)
M4 multi-hole plates						
R-PV-13150150-10-4	M4	13 mm	150 mm	150 mm	1	10 mm
R-PV-13200200-10-4	M4	13 mm	200 mm	200 mm	1	10 mm
R-PV-13250150-10-4	M4	13 mm	250 mm	150 mm	1	10 mm
R-PV-13250250-10-4	M4	13 mm	250 mm	250 mm	1	10 mm
M4 multi-window plates						
R-PV-W-13200200-10-4	M4	13 mm	200 mm	200 mm	5	10 mm
R-PV-W-13250150-10-4	M4	13 mm	250 mm	150 mm	3	10 mm
R-PV-W-13250250-10-4	M4	13 mm	250 mm	250 mm	5	10 mm
R-PV-W-13400400-10-4	M4	13 mm	400 mm	400 mm	7	10 mm
M6 multi-hole plates						
R-PV-13150150-12-6	M6	13 mm	150 mm	150 mm	1	12.5 mm
R-PV-13250250-12-6	M6	13 mm	250 mm	250 mm	1	12.5 mm
M6 multi-window plates						
R-PV-W-13250250-12-6	M6	13 mm	250 mm	250 mm	5	12.5 mm
R-PV-W-13400400-12-6	M6	13 mm	400 mm	400 mm	7	12.5 mm

*OC – on centre.

Interchangeable vision fixture

7.1

Interchangeable vision fixture

Renishaw's interchangeable vision fixture (IVF) is ideal for machines 450 mm x 450 mm or larger.

This fixture consists of a frame and multiple subplates that can be designed to use all, half, or a quarter of the frame's total size.

The frame is made from anodised aluminium and designed to fit your specific vision machine. The frame also allows for the mounting of your probe rack and calibration artefacts.

The interchangeable subplates can be modular with M4 or M6 threaded holes (10 mm or 12.5 mm on centre) or custom. To ensure you receive the correct size and proper fit, include your machine make and model number when ordering.

A combination of both custom and modular subplates and components can be added and made to fit the same frame, allowing for maximum flexibility.

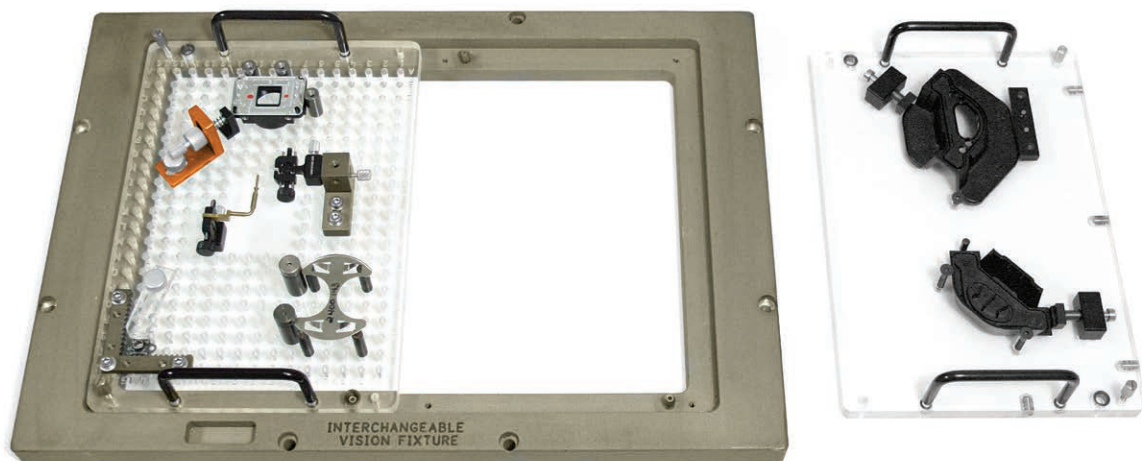

Adjustables

9.1

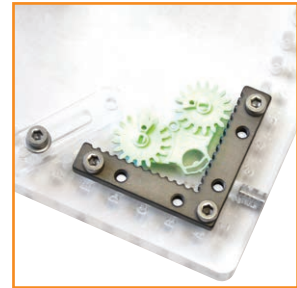
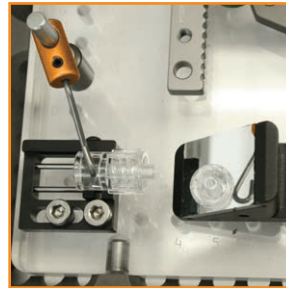
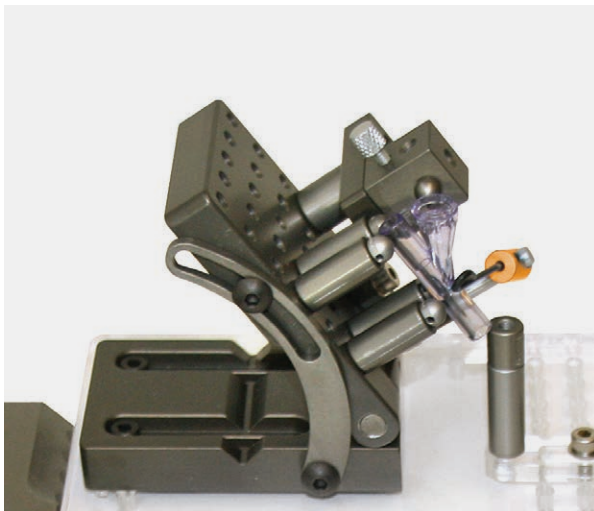

Adjustable jack stand

To allow variable heights of up to 22 mm and then lock into position.



R-AJ-25-6

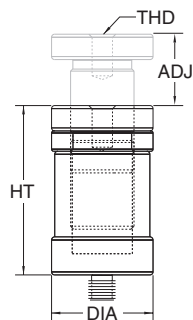

Part no.	THD	DIA	HT	ADJ
R-AJ-9-4	M4	9 mm	19 mm	7 mm
R-AJ-13-6	M6	17 mm	42 mm	13 mm
R-AJ-25-6	M6	25 mm	42 mm	13 mm

Adjustable pivot joint

For positioning a component at any angle. Lock the rotating base into position and then set the angle of the pivot.



R-APJ-6

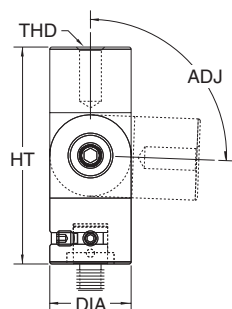

Part no.	THD	DIA	HT	ADJ
R-APJ-6	M6	19 mm	50 mm	93°

Adjustable slide

To place components in between holes on the plate.

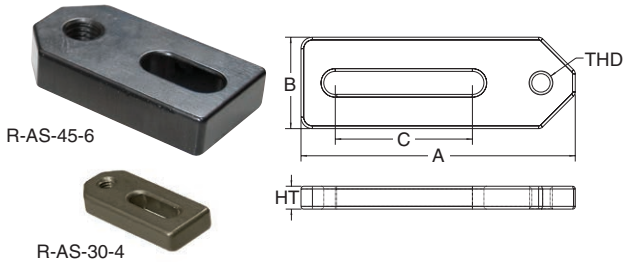

Part no.	THD	HT	A	B	C
R-AS-30-4	M4	5 mm	30 mm	13 mm	9 mm
R-ASA-45-4 (acrylic)	M4	5 mm	45 mm	13 mm	24 mm
R-AS-45-4	M4	5 mm	45 mm	13 mm	24 mm
R-ASA-45-6 (acrylic)	M6	10 mm	44 mm	20 mm	13 mm
R-AS-45-6	M6	10 mm	44 mm	20 mm	13 mm
R-AS-70-6	M6	10 mm	72 mm	25 mm	34 mm

Included: socket head cap and thumb screws.

Adjustable V-post

For holding cylindrical or tubular parts without marring the part's surface. Can be rotated and locked to any orientation.

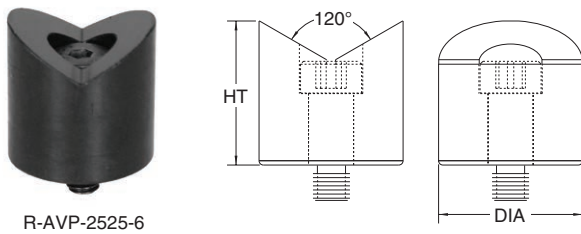

Part no.	THD	DIA	HT	ADJ
R-AVP-2525-6	M6	25 mm	25 mm	360°

Included: shoulder bolt.

Adjustable height stand

To allow variable heights without marring the part.

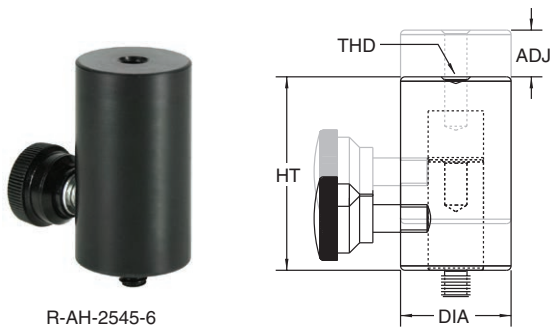

Part no.	THD	DIA	HT	ADJ
R-AH-2545-6	M6	25 mm	45 mm	9 mm

Adjustable angle plate

Ideal for holding components on an angle. The angle plate is adjustable to 180°.

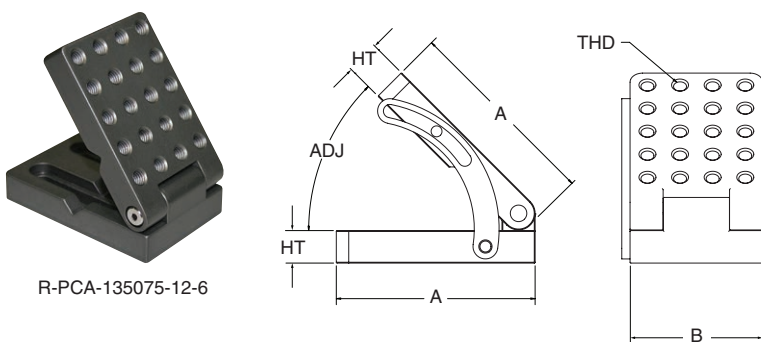

Part no.	THD	HT	A	B	ADJ
R-PCA-135075-10-4	M4	13 mm	75 mm	50 mm	180°
R-PCA-135075-12-6	M6	13 mm	75 mm	50 mm	180°

Adjustable slide mirror

To aid viewing and inspecting a part.

Part no.	THD	HT	A	B	C
R-ASM-4	M4	29 mm	75 mm	20 mm	34 mm



R-ASM-4

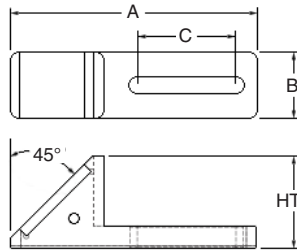

Adjustable slide acrylic extension

Screw any component onto the acrylic slide to extend the reach of the component.

Part no.	THD	HT	A	B	C	ADJ
R-ASAE-4	M4	10 mm	82 mm	13 mm	25 mm	190°



R-ASAE-4

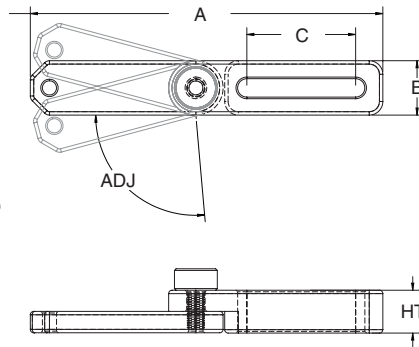

Micro adjustable V

For cylindrical parts smaller than 6.5 mm in diameter.

Part no.	THD	HT	A	B	C
R-AVM-4	M4	8 mm	25 mm	24 mm	10 mm



R-AVM-4

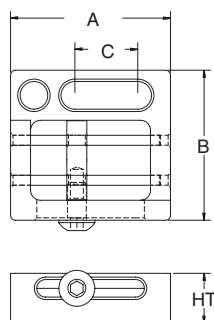

Clamps

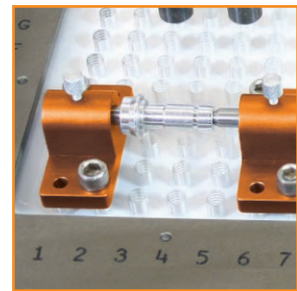

Tension clamp

For quick and easy clamping.



R-CT-64-70-6 R-CT-40-30-6

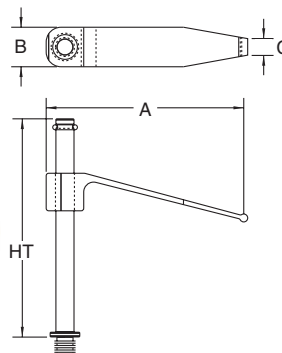

Part no.	THD	HT	A	B	C
R-CT-40-25-4	M4	25 mm	40 mm	7.6 mm	4 mm
R-CT-40-30-6	M6	30 mm	40 mm	7.6 mm	4 mm
R-CT-40-70-6	M6	68 mm	40 mm	7.6 mm	4 mm
R-CT-64-70-6	M6	68 mm	63.5 mm	13 mm	5 mm
R-CT-95-83-6	M6	83 mm	96 mm	19 mm	9 mm
R-CT-100P-83-6*	M6	83 mm	105 mm	19 mm	9 mm

* includes a plunger for reaching over the edge of a part to a more rigid surface or to reach over another support component.

Part number on tension clamp is for reference only. See chart for complete dimensions.

Soft tip tension clamp

Rubber coated tips hold parts without scratching or marring the surface of a part.



R-CTT-64-70-6

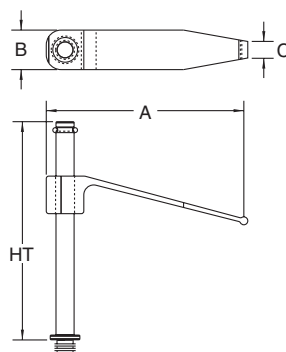

Part no.	THD	HT	A	B	C
R-CTT-40-25-4	M4	25 mm	40 mm	7.6 mm	4 mm
R-CTT-40-30-6	M6	30 mm	40 mm	7.6 mm	4 mm
R-CTT-40-70-6	M6	68 mm	40 mm	7.6 mm	4 mm
R-CTT-64-70-6	M6	68 mm	63.5 mm	13 mm	5 mm
R-CTT-95-83-6	M6	83 mm	96 mm	19 mm	9 mm

Part number on soft tip tension clamp is for reference only. See chart for complete dimensions.

Spring wire clamp

For light clamping of small parts minimising the contact area on a part and for least possible obstruction.

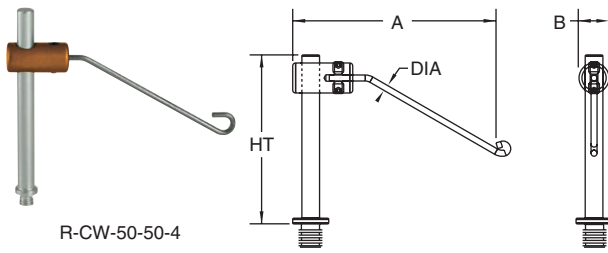

Part no.	THD	HT	A	B	DIA
R-CW-25-25-4	M4	25 mm	36 mm	8 mm	1.5 mm
R-CW-50-50-4	M4	45 mm	55 mm	8 mm	1.5 mm
R-CW-25-25-6	M6	25 mm	36 mm	8 mm	1.5 mm
R-CW-50-50-6	M6	50 mm	55 mm	8 mm	1.5 mm

Part number on spring wire clamp is for reference only. See chart for complete dimensions.

Soft tip spring wire clamp

With rubber coated tips for light clamping of small parts, minimising the contact area on a part and for least possible obstruction.

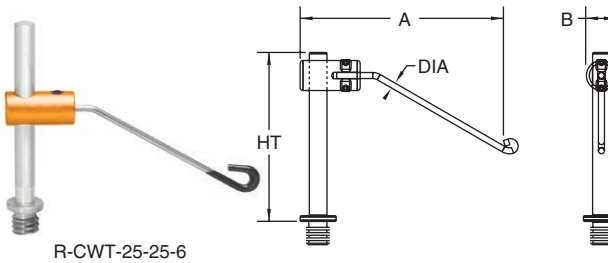

Part no.	THD	HT	A	B	DIA
R-CWT-25-25-4	M4	25 mm	36 mm	8 mm	1.5 mm
R-CWT-50-50-4	M4	45 mm	55 mm	8 mm	1.5 mm
R-CWT-25-25-6	M6	25 mm	36 mm	8 mm	1.5 mm
R-CWT-50-50-6	M6	50 mm	55 mm	8 mm	1.5 mm

Part number on spring wire clamp is for reference only. See chart for complete dimensions.

Pusher clamp

To push a part against standoffs or into corner (two interchangeable tips are included).

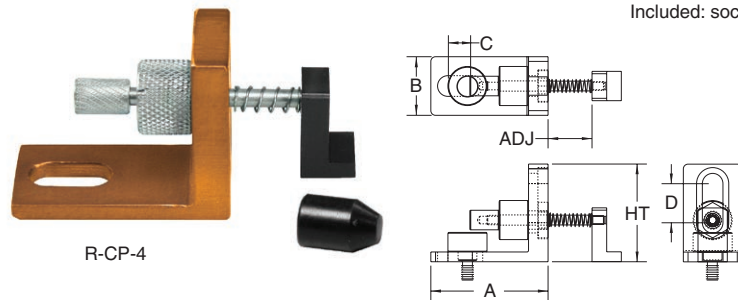

Part no.	THD	HT	A	B	C	D	ADJ
R-CP-4	M4	32 mm	38 mm	19 mm	8 mm	13 mm	10 mm
R-CP-6	M6	32 mm	38 mm	19 mm	8 mm	13 mm	10 mm

Included: socket head cap screw, thumb screw and washer.

Screw pusher clamp

For pushing and holding a part against stops.

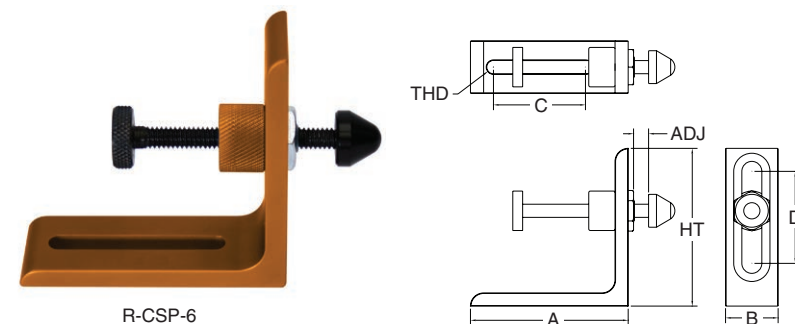

Part no.	THD	HT	A	B	C	D	ADJ
R-CSP-6	M6	76 mm	76 mm	25 mm	44 mm	44 mm	38 mm

Included: socket head cap screw, thumb screw and washer.

Centres

For holding cylindrical parts at each end on their inside diameters.

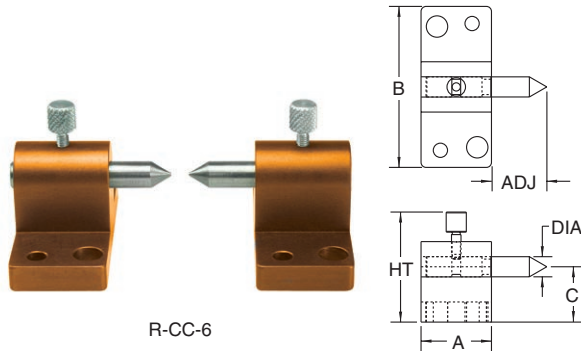

R-CC-6

Part no.	THD	DIA	HT	A	B	C	ADJ
R-CC-6	M4/M6	6 mm	38 mm	22 mm	51 mm	20 mm	16 mm
R-CC-13	M4/M6/M8	13 mm	50 mm	38 mm	64 mm	25 mm	38 mm
R-CC-25	M4/M6/M8	25 mm	69 mm	51 mm	76 mm	35 mm	50 mm

Included: both male and female centring options; socket head cap screws.

Micro centre

Has adjustability to hold cylindrical parts up to 26 mm in length and 25.5 mm in diameter.

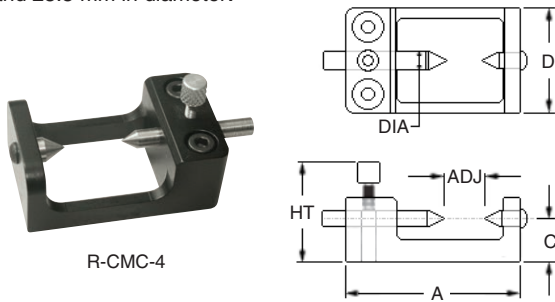

R-CMC-4

Part no.	THD	DIA	HT	A	B	C	D
R-CMC-4	M4	4.8 mm	30 mm	51 mm	32 mm	12.5 mm	25.5 mm

Mini vice

For clamping a small area of a part. The vice can be rotated 360° and then locked into position.

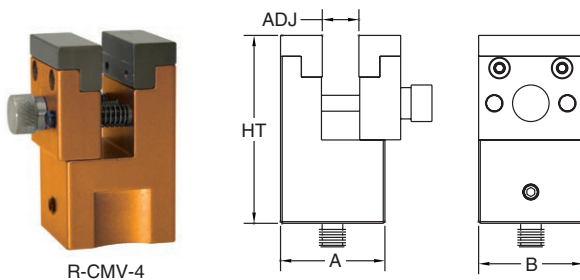

R-CMV-4

Part no.	THD	HT	A	B	ADJ
R-CMV-4	M4	58 mm	32 mm	32 mm	11 mm
R-CMV-6	M6	58 mm	32 mm	32 mm	11 mm

Micro vice clamp

Ideal for holding parts horizontally or vertically. The jaws have a V notch for holding cylindrical and tubular parts.

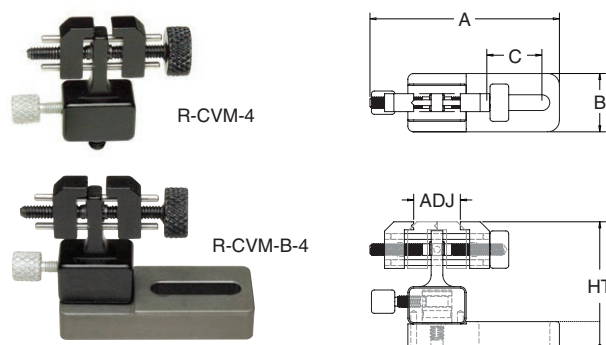

R-CVM-4

R-CVM-B-4

Part no.	THD	HT	A	B	C	ADJ
R-CVM-4	M4	28 mm	38 mm	10 mm	–	13 mm
R-CVM-B-4 (with base)	M4	35 mm	51 mm	16 mm	15 mm	13 mm
R-CVM-6	M6	28 mm	38 mm	10 mm	–	13 mm
R-CVM-B-6 (with base)	M6	38 mm	78 mm	20 mm	35 mm	13 mm

Spring pusher standoff clamp

Designed for fixturing small parts in tight or compact space.
Ideal for positioning parts and for profile clamping.

Part no.	THD	DIA	HT	A
R-CSPS-1210-4	M4	12 mm	10 mm	4 mm
R-CSPS-1925-6	M6	19 mm	25 mm	10 mm

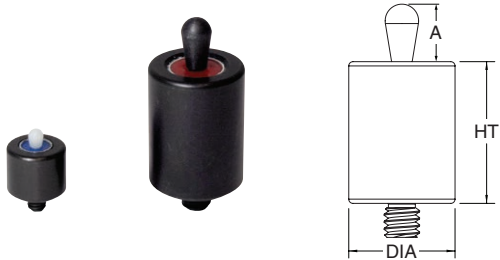

R-CSPS-1210-4 R-CSPS-1925-6

Rotating 3-jaw clamp

For clamping on inner and outer diameter of part, locking into position then rotated to a marked increment.

Part no.	THD	HT	A	B	C	D	ADJ
R-CJR-3	M4/M6	60 mm	102 mm	70 mm	38 mm	6.4 mm	1-63 mm

Included: socket head cap screws and chuck keys.



R-CJR-3

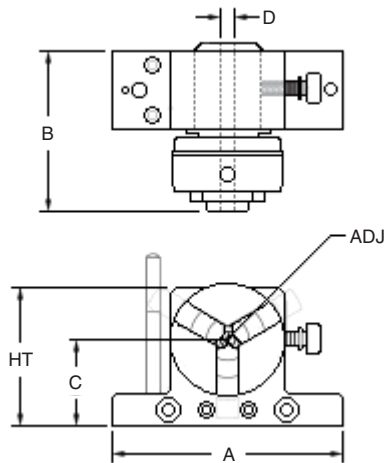

Magnets

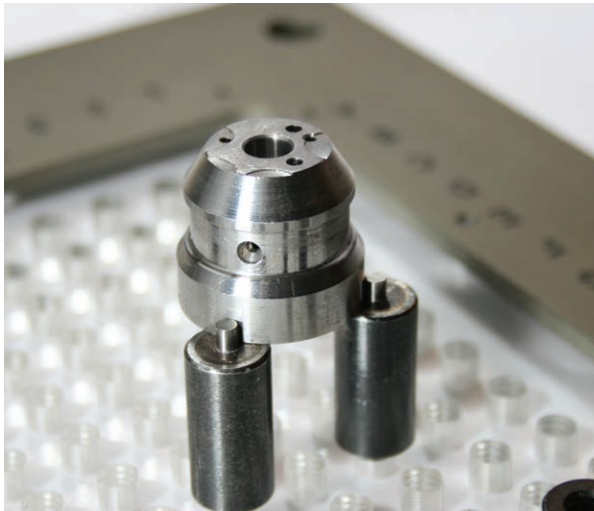

Magnet

For holding steel or iron parts.



R-M-19-6

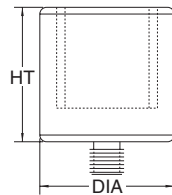

Part no.	THD	DIA	HT
R-M-6-4	M4	6 mm	25 mm
R-M-13-4	M4	13 mm	25 mm
R-M-13-6	M6	13 mm	25 mm
R-M-19-6	M6	19 mm	25 mm
R-M-25-6	M6	25 mm	25 mm
R-M-32-6	M6	32 mm	25 mm

Pin magnet

For holding and locating steel or iron parts.



R-MP-13-6

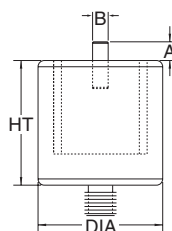

Part no.	THD	DIA	HT	A	B
R-MP-6-4	M4	6 mm	25 mm	3.8 mm	1.6 mm
R-MP-13-4	M4	13 mm	25 mm	3.8 mm	1.6 mm
R-MP-13-6	M6	13 mm	25 mm	3.8 mm	3 mm
R-MP-19-6	M6	19 mm	25 mm	3.8 mm	3 mm
R-MP-25-6	M6	25 mm	25 mm	3.8 mm	3 mm

V magnet

For holding cylindrical parts and bent tubing.



R-MV-25-6

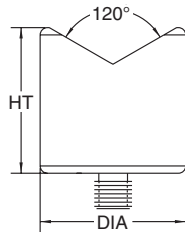

Part no.	THD	DIA	HT
R-MV-13-6	M6	13 mm	25 mm
R-MV-19-6	M6	19 mm	25 mm
R-MV-25-6	M6	25 mm	25 mm
R-MV-32-6	M6	32 mm	25 mm

V magnet with base

For holding round and tubular parts.



R-MVB-25-6

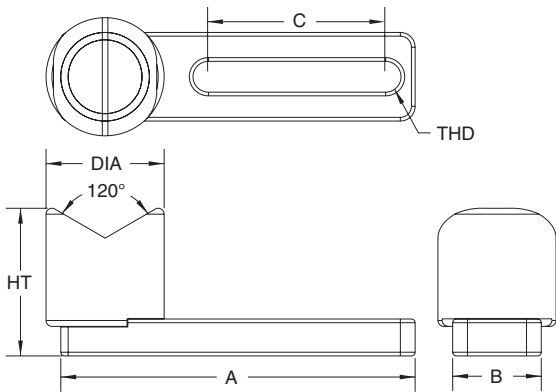

Part no.	THD	DIA	HT	A	B	C
R-MVB-13-6	M6	13 mm	32 mm	76 mm	19 mm	36 mm
R-MVB-19-6	M6	19 mm	32 mm	76 mm	19 mm	36 mm
R-MVB-25-6	M6	25 mm	32 mm	76 mm	19 mm	36 mm
R-MVB-32-6	M6	32 mm	32 mm	76 mm	19 mm	36 mm

Included: socket head cap, thumb screws and washers.

Miscellaneous

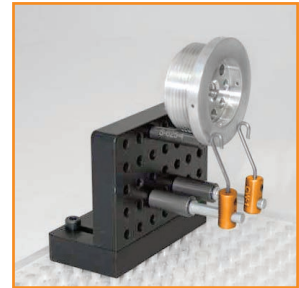
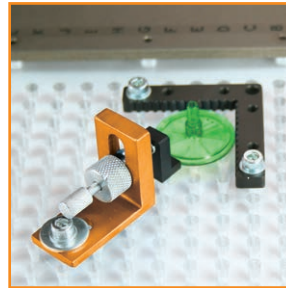

Cone

To rest a part on a rounded point for single-point contact.



Part no.	THD	DIA	HT	Material
R-RCD-6	M6	16 mm	13 mm	Delrin®
R-RCS-6	M6	16 mm	13 mm	Steel
R-RCA-6	M6	25 mm	19 mm	Aluminium

Resting pin

To rest a part on a rounded point.



Part no.	THD	DIA	HT	A	Material
R-RPD-4	M4	6 mm	5 mm	1.9 mm	Delrin®
R-RPA-4	M4	6 mm	5 mm	1.9 mm	Aluminium
R-RPD-6	M6	9 mm	10 mm	1.9 mm	Aluminium
R-RPS-6	M6	9 mm	10 mm	1.9 mm	Steel

Screws and adaptors

Component replacement parts.



R-AATK-6 R-AATS-20 R-AATS-14 R-ATS-4 R-AAS-6

Part no.	THD	DIA	HT
Thumb screw			
R-AATK-6	M6	12 mm	20 mm
Screw			
R-AATS-14	M3	6 mm	15 mm
R-AATS-20	M3	6 mm	20 mm
R-ATS-4	M4	13 mm	15 mm
Adaptor			
R-AAS-4	M4	8 mm	15 mm
R-AAS-6	M6	8 mm	15 mm

Vertical base plate

For holding components vertically.



R-PCV-507540-10-4

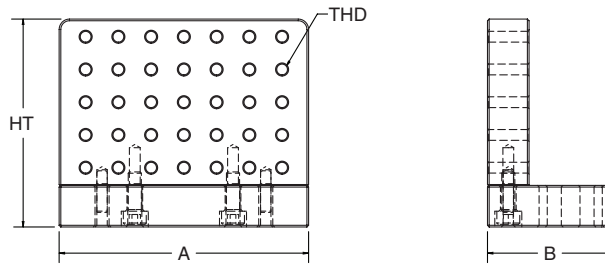

Part no.	THD	HT	A	B
R-PCV-507540-10-4	M4	63.5 mm	75 mm	40 mm

Corner viewor

For allowing a part to be located in a corner. The serrations allow backlighting along the sides of the part.

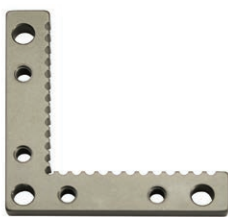

R-VC-5050-4

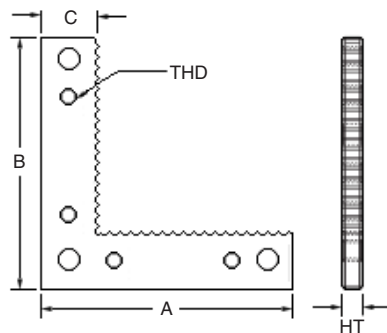

Part no.	THD	HT	A	B	C
R-VC-5050-4	M4	5 mm	50 mm	50 mm	10 mm
R-VC-7575-6	M6	6 mm	83 mm	83 mm	19 mm

Included: socket head cap screws.

Standoffs

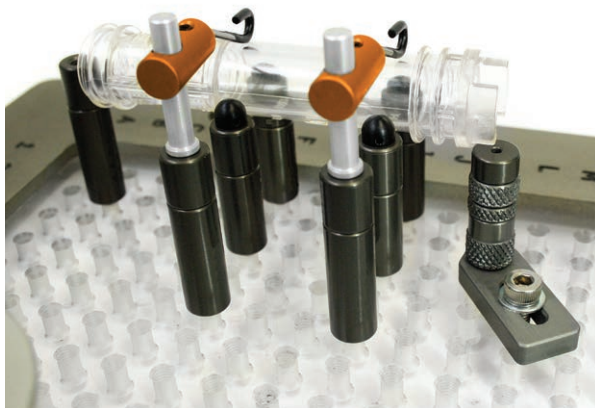

Standoff

To elevate and locate a part.

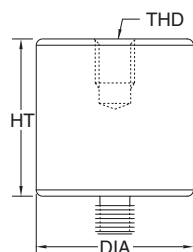

Part no.	THD	DIA	HT	Part no.	THD	DIA	HT
M4 standoffs				M6 standoffs			
R-S-65-4*	M4	6 mm	5 mm	R-S-610-6*	M6	6 mm	10 mm
R-S-610-4*	M4	6 mm	10 mm	R-S-625-6*	M6	6 mm	25 mm
R-S-615-4*	M4	6 mm	15 mm	R-S-95-6*	M6	9 mm	5 mm
R-S-620-4*	M4	6 mm	20 mm	R-S-910-6	M6	9 mm	10 mm
R-S-625-4*	M4	6 mm	25 mm	R-S-915-6	M6	9 mm	15 mm
R-S-95-4*	M4	9 mm	5 mm	R-S-920-6	M6	9 mm	20 mm
R-S-910-4	M4	9 mm	10 mm	R-S-925-6	M6	9 mm	25 mm
R-S-915-4	M4	9 mm	15 mm	R-S-1310-6	M6	13 mm	10 mm
R-S-920-4	M4	9 mm	20 mm	R-S-1315-6	M6	13 mm	15 mm
R-S-925-4	M4	9 mm	25 mm	R-S-1320-6	M6	13 mm	20 mm
R-S-950-4	M4	9 mm	50 mm	R-S-1325-6	M6	13 mm	25 mm
R-S-125-4*	M4	12 mm	5 mm	R-S-1350-6	M6	13 mm	50 mm
R-S-1210-4	M4	12 mm	10 mm	R-S-13100-6	M6	13 mm	100 mm
R-S-1215-4	M4	12 mm	15 mm	R-S-13150-6	M6	13 mm	150 mm
R-S-1220-4	M4	12 mm	20 mm	R-S-1910-6	M6	19 mm	10 mm
R-S-1225-4	M4	12 mm	25 mm	R-S-1915-6	M6	19 mm	15 mm
R-S-1250-4	M4	12 mm	50 mm	R-S-1920-6	M6	19 mm	20 mm
				R-S-1925-6	M6	19 mm	25 mm
				R-S-1950-6	M6	19 mm	50 mm
				R-S-19100-6	M6	19 mm	100 mm
				R-S-19150-6	M6	19 mm	150 mm
				R-S-2515-6	M6	25 mm	15 mm
				R-S-2520-6	M6	25 mm	20 mm
				R-S-2525-6	M6	25 mm	25 mm
				R-S-2550-6	M6	25 mm	50 mm
				R-S-25100-6	M6	25 mm	100 mm
				R-S-25150-6	M6	25 mm	150 mm
				R-S-3825-6	M6	38 mm	25 mm
				R-S-3850-6	M6	38 mm	50 mm
				R-S-38150-6	M6	38 mm	150 mm

* = does not have a threaded top.
M4 standoffs are made of aluminium.
M6 standoffs are made of steel.

Delrin® standoffs

To elevate and locate a part using a non-marring material.

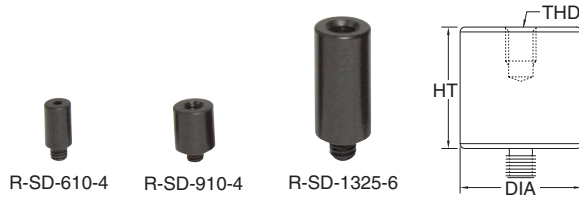

Part no.	THD	DIA	HT
R-SD-610-4	M4	6 mm	10 mm
R-SD-910-4	M4	9 mm	10 mm
R-SD-1210-4	M4	12 mm	10 mm
R-SD-925-6	M6	9 mm	25 mm
R-SD-1325-6	M6	13 mm	25 mm
R-SD-1925-6	M6	19 mm	25 mm

Pin standoff

To elevate and locate a part against the pin.

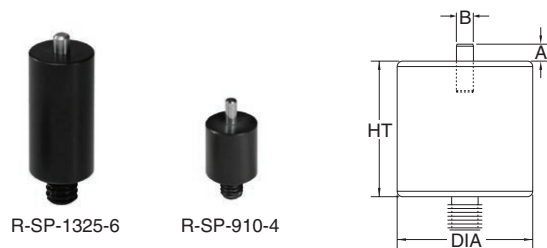

Part no.	THD	DIA	HT	A	B
R-SP-610-4	M4	6 mm	10 mm	3.8 mm	2 mm
R-SP-910-4	M4	9 mm	10 mm	3.8 mm	2 mm
R-SP-1210-4	M4	12 mm	10 mm	3.8 mm	2 mm
R-SP-610-6	M6	6 mm	10 mm	3.8 mm	2 mm
R-SP-910-6	M6	9 mm	10 mm	3.8 mm	2 mm
R-SP-1325-6	M6	13 mm	25 mm	3.8 mm	3 mm
R-SP-1925-6	M6	19 mm	25 mm	3.8 mm	3 mm

Delrin® pin standoffs

To elevate and locate a part against a pin using a non-marring material.

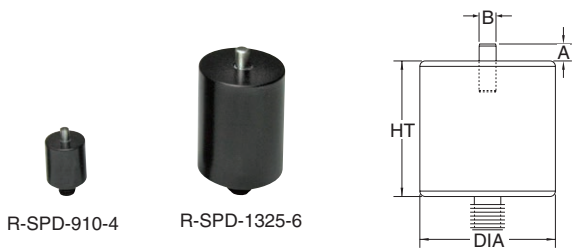

Part no.	THD	DIA	HT	A	B
R-SPD-910-4	M4	9 mm	10 mm	3.8 mm	2 mm
R-SPD-1325-6	M6	13 mm	25 mm	3.8 mm	3 mm

2-way and 4-way spring-loaded pin standoff

For locating within a hole or slot of a part.

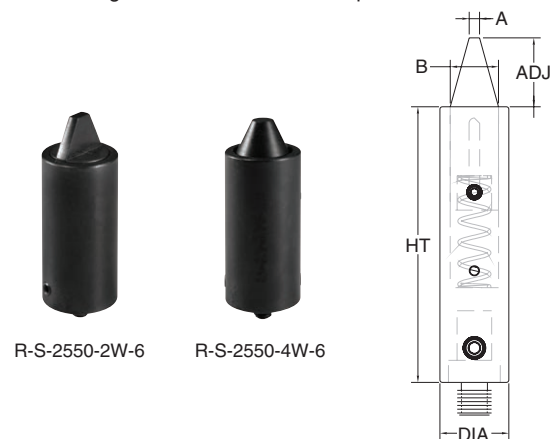

Part no.	THD	DIA	HT	A	B	ADJ
2-way pins						
R-S-1350-2W-6	M6	13 mm	50 mm	2 mm	9 mm	12.5 mm
R-S-2550-2W-6	M6	25 mm	50 mm	7 mm	19 mm	12.5 mm
4-way pins						
R-S-1350-4W-6	M6	13 mm	50 mm	2 mm	9 mm	12.5 mm
R-S-2550-4W-6	M6	25 mm	50 mm	7 mm	19 mm	12.5 mm

Standoff adaptor

For step clamps and calibration sphere.



R-SA-8-6

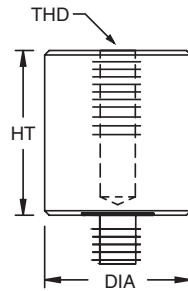

Part no.	THD	DIA	HT	A
R-SA-6-4	M4	19 mm	15 mm	M6
R-SA-4-6	M6	9 mm	15 mm	M4
R-SA-8-6	M6	25 mm	25 mm	M8

Rotator standoff

To secure parts against stops/supports.



R-SR-2525-6

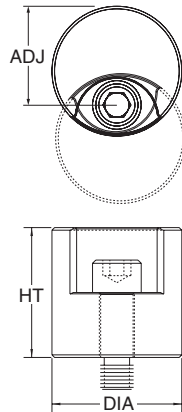

Part no.	THD	DIA	HT	ADJ
R-SR-2525-6	M6	25 mm	25 mm	19 mm

Towers

14.1

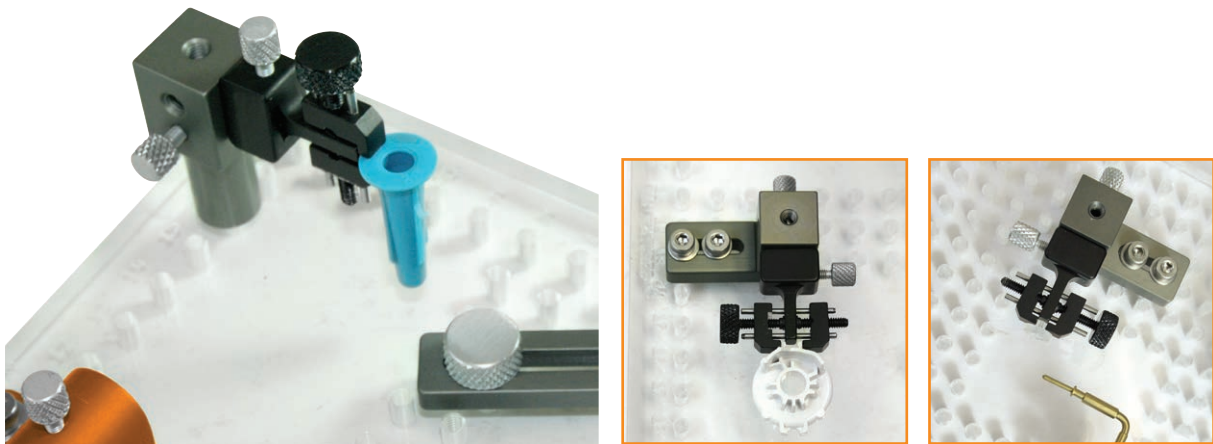

Tower

To hold a part vertically.

Part no.	THD	HT	A	B	C	Threaded rows
----------	-----	----	---	---	---	---------------

R-T-25150-6 M6 150 mm 127 mm 25 mm 25 mm 1

Included: socket head cap screws.

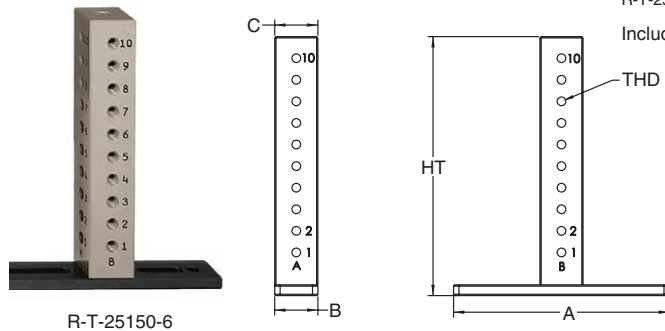

R-T-25150-6

Tower block with base

For positioning a component vertically to the part set-up. Can be used without the base to allow full rotation.

Part no.	THD	HT	A	B	C	D
----------	-----	----	---	---	---	---

R-TB-1619-4 M4 26 mm 41 mm 16 mm 16 mm 15 mm

R-TB-2025-6 M6 35 mm 70 mm 20 mm 20 mm 35 mm

Included: socket head cap screws.

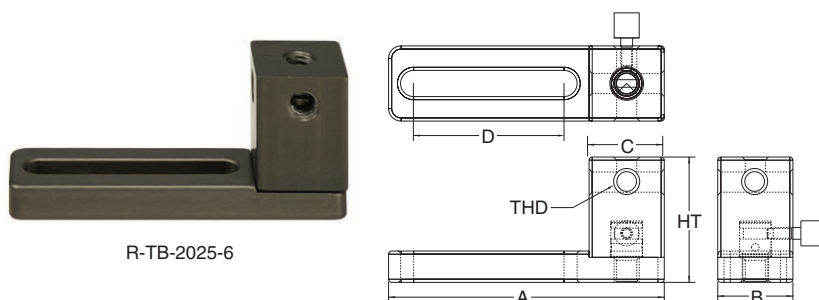

R-TB-2025-6

Trays

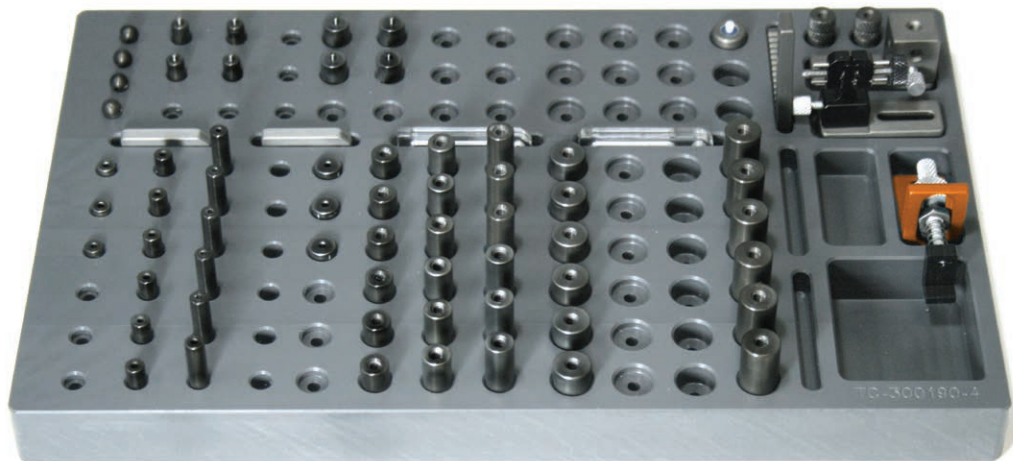

Medium component tray

To hold and organise components.

Part no.	THD	Height	Length	Width
R-TC-500200	M6/M8	25 mm	500 mm	200 mm



R-TC-500200

Small component tray

To hold and organise components.

Part no.	THD	Height	Length	Width
R-TC-300190-4	M4	25 mm	300 mm	190 mm
R-TC-300190-6	M6	25 mm	300 mm	190 mm

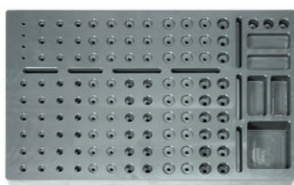

R-TC-300190-4

Component storage box

10-compartment box to hold and organise components.



R-BC10

Part no.	Height	Length	Width
R-BC10	45 mm	203 mm	152 mm

Custom fixtures

Custom fixtures for your application

If Renishaw's standard range of modular fixturing does not meet your requirements, we can provide you with custom fixtures for your vision system.

Renishaw's engineers will design and develop a custom fixture best suited to your requirements. All aspects of the application are taken into consideration, including:

- how frequently the part will be measured
- the type of material, size and shape of the part
- the dimensions and tolerances of the part
- the datums or orientation of the part
- the weight and size of the fixture.

To enable us to provide the best solution, you can submit your pictures, parts, drawings or CAD files for review. For more information, please contact your local sales office.

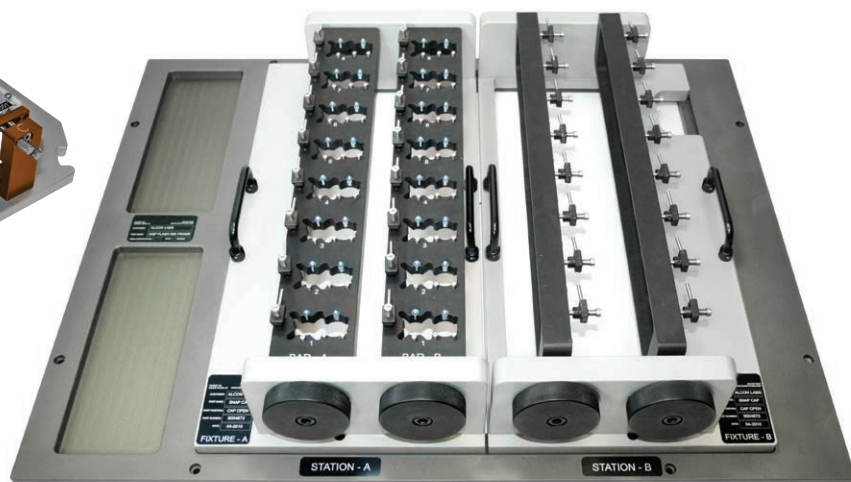
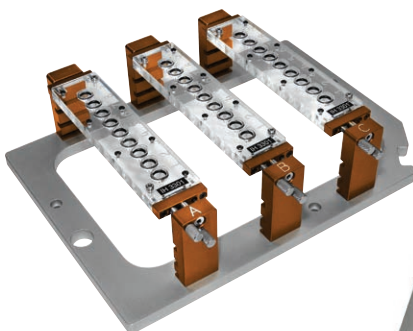
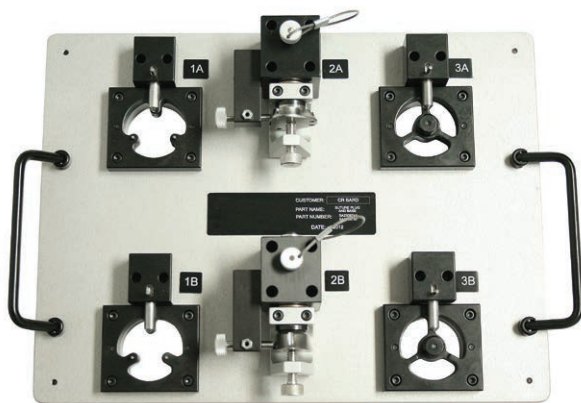

About Renishaw

Renishaw is an established world leader in engineering technologies, with a strong history of innovation in product development and manufacturing. Since its formation in 1973, the company has supplied leading-edge products that increase process productivity, improve product quality and deliver cost-effective automation solutions.

A worldwide network of subsidiary companies and distributors provides exceptional service and support for its customers.

Products include:

- Additive manufacturing and vacuum casting technologies for design, prototyping, and production applications
- Dental CAD/CAM scanning systems and supply of dental structures
- Encoder systems for high-accuracy linear, angle and rotary position feedback
- Fixturing for CMMs (co-ordinate measuring machines) and gauging systems
- Gauging systems for comparative measurement of machined parts
- High-speed laser measurement and surveying systems for use in extreme environments
- Laser and ballbar systems for performance measurement and calibration of machines
- Medical devices for neurosurgical applications
- Probe systems and software for job set-up, tool setting and inspection on CNC machine tools
- Raman spectroscopy systems for non-destructive material analysis
- Sensor systems and software for measurement on CMMs
- Styli for CMM and machine tool probe applications

For worldwide contact details, visit www.renishaw.com/contact



RENISHAW HAS MADE CONSIDERABLE EFFORTS TO ENSURE THE CONTENT OF THIS DOCUMENT IS CORRECT AT THE DATE OF PUBLICATION BUT MAKES NO WARRANTIES OR REPRESENTATIONS REGARDING THE CONTENT. RENISHAW EXCLUDES LIABILITY, HOWSOEVER ARISING, FOR ANY INACCURACIES IN THIS DOCUMENT.

© 2013 – 2015 Renishaw plc. All rights reserved.

Renishaw reserves the right to change specifications without notice.

RENISHAW and the probe symbol used in the **RENISHAW** logo are registered trade marks of Renishaw plc in the United Kingdom and other countries. **apply innovation** and names and designations of other Renishaw products and technologies are trade marks of Renishaw plc or its subsidiaries. All other brand names and product names used in this document are trade names, trade marks or registered trade marks of their respective owners.



H - 1000 - 0079 - 02

Part no.: H-1000-0079-02-A
Issued: 06.2015