

FERMAT



SPECIALIZING IN PRECISION

HORIZONTAL BORING MILLS



FERMAT

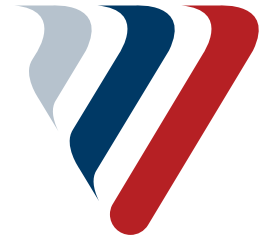

WRF 160 Heavy CNC

for D & S Machine Service Inc., USA

Parameters: X = 27000 mm (1062.99") | Y = 5000 mm (196.85") | Z = 1500 mm (59.05") | W = 1000 mm (39.37") |
Rotary Table = T 50, 3500 x 3500 mm (137.79 x 137.79") | CTS = 20 | ATC = 60 | UHAmi30 | PHA 37/2,5 st

Content

Fermat Fast Facts	4
About Fermat	5
Summary Table-Type Horizontal Boring Mills	6
Summary Floor-Type Horizontal Boring Mills	7
TABLE-TYPE HORIZONTAL BORING MILLS	8
WFC 10	8
WFT 11	10
WFT 13	12
WFT 15	14
FLOOR-TYPE HORIZONTAL BORING MILLS	16
WF 13 / 15	16
WRF 130 / 150 / 160	18
WRF 2G 150 / 160	20
WRF HEAVY 160	22
SPECIAL ACCESSORIES	24
Rotary Table	24
Automatic Pallet Changer System APC	25
Milling Heads Facing Heads	26
Pick-up Station	32
Automatic Tool Changer ATC	33
REFERENCES	36

About Fermat



Number of employees

527



Annual sales in 2018

€ 80 mil.



Oldest member of Fermat Group (Lucas)

1901



Plants in the Czech Republic

8



Other branches worldwide

6



Annual production / sold machines

100+



1 micron is the most accurate production machine in our machining shop

1µm

PRAGUE
CZECH REPUBLIC

FRANCE

GERMANY

POLAND

CZECHIA

SLOVAKIA

AUSTRIA



WORLD

Since 1990, FERMAT has grown to be a leading European manufacturer of CNC machine tools. Thanks to superb engineering, outstanding technology and modern design, FERMAT manufactures the most powerful and precise CNC table-type and floor-type horizontal boring mills, as well as cylindrical grinders, available anywhere on the market. FERMAT provides both standard and custom-built machines, with features to suit all production demands. Each FERMAT machine can be equipped with a large number of accessories enhancing manufacturing and improving production.

FERMAT's product lines include CNC horizontal boring mills and milling machines, milling heads, gantries, bridge mills, cylindrical grinders, rotary tables, and other machine tools and accessories. As a result of its modular design of manufacturing and expert workforce, FERMAT can reconfigure and build its horizontal boring mills to meet almost any requirement a customer may have.

Worldwide Sales and Distribution

Based in the heart of Europe, FERMAT is one of the leading suppliers of machine tools in Central Europe. The company celebrated achievements not only in European markets, but also in Canada, USA, Russia, India, China and South America, exporting to more than 40 countries worldwide. FERMAT is constantly growing and increasing its market share and participates in main International Fairs around the world including EMO – the leading International Trade Fair for the machine tool industry and IMTS – the largest machine tool exhibition for the North American market.

- **FERMAT's main manufacturing and assembly facilities** in Prague, Brno, and Lipník nad Bečvou, Czech Republic, occupying a total area equivalent to over 5 football fields, with room to spare. With new facilities being built for FERMAT's every expanding line of machine tools, capital expansion is set to continue.
- **FERMAT CZ & FERMAT Group** design, manufacture and sell horizontal boring mills, both table-type and floor-type, as well as milling machines, milling heads, machine tool accessories and strong after market parts and service support.
- **FERMAT Pressl** concentrates on rebuilding and retrofitting used horizontal boring mills and other machine tools.
- **FERMAT Machine Tool** produces and sells cylindrical grinders and related accessories and they also provide customer service.
- **FERMAT Stroje Lipník** designs, manufactures and assembles horizontal boring mills (focusing mainly on table-type), as well as milling machines and milling heads.
- **LUCAS Precision** is a subsidiary of FERMAT representing the company and selling FERMAT products in the US market, Lucas also manufactures and provides after market parts and service.
- **FERMAT GmbH** is FERMAT's branch in Germany selling and servicing its machines in German-speaking markets.
- **FERMAT J & F Stroje** and **FERMAT Opravy** sell and service FERMAT machines in Slovakia. They also make machine tool components, manufacture automatic pick-up stations, and are involved in the production of FERMAT machines and presses.
- **FERMAT Machinery Pvt. Ltd** is FERMAT's branch in India selling and servicing its machines in the Indian market.
- **FERMAT Gépek kft.** is FERMAT's branch in Hungary selling and servicing its machines in the Hungarian market.



Table Type Horizontal Boring Mills

8

see page



WFC 10

Economical, modern, and compact solution. It is a continuously controlled cross-type or moving saddle machine of a modern design, ideal for powerful and complete machining of workpieces of up to 5 tons.

- Spindle diameter 100 mm or 110 mm; spindle travel 730 mm.
- Suitable for both single, one-off machining of a workpiece or serial production; ideal for manufacturing facilities with space limitations.
- Version WFC 10 L equipped with linear guideways.
- CNC rotary table (2 servo motors), suitable for machining molds.

10

see page



WFT 11

Middle size table-type horizontal boring mill with longitudinally movable column base for the Z axis, and a table movable in a crosswise way for efficient machining of workpieces of up to 10 tons.

- Spindle diameter 100 mm or 110 mm; spindle travel 730 mm.
- Optional version with longer X axis (3, 4, or 5 meters) for larger workpieces weighing up to 20 metric tons.
- It is possible to equip the pallet change system to speed up processing.
- Suitable for machining both longer weldments and complex welded frames.

12

see page



WFT 13

Most popular FERMAT table-type horizontal boring mill, for high-performance machining with maximum utilization of accessories and automatic milling heads for efficient machining of workpieces of up to 20 tons.

- Spindle diameter 130 mm or 110 mm; spindle travel 800 mm.
- Optional ram stroke 700 mm.
- Powerful and precise milling, coordinate drilling, boring, and threading.
- Extremely versatile series of table-type horizontal boring mills, fully compatible with a wide range of accessories and automatic milling heads.

14

see page



WFT 15

Similar to WFT 13, but with a spindle diameter of 150 mm. Ideal for even larger and heavier workpieces up to 20 tones (optionally up to 40 tones).

- Spindle diameter 150 mm; spindle travel 800 mm.
- Optional ram stroke 700 mm, total extension along the axis $W = 1500$ mm.
- Optional spindle travel of 1 meter.
- Extremely versatile series of table-type horizontal boring mills, fully compatible with a wide range of accessories and automatic milling heads.

Floor Type Horizontal Boring Mills

WF

FERMAT's floor-type horizontal boring mill for powerful and precise, high-performance coordinate drilling, boring, and threading large and heavy workpieces.

- Spindle diameter 130 mm or 150 mm; spindle travel 800 mm.
- Optional ram stroke of 700 mm.
- Equipped with floor plates and/or rotary tables.
- Fully compatible with a wide range of accessories and automatic milling heads.



16

see page

WRF

WRF is FERMAT's large, robust series of floor-type horizontal boring mills, excellent for powerful and precise machining of enormous, heavy workpieces.

- Spindle diameter of 130 mm, 150 mm, or 160 mm; spindle travel from 800 mm to 1 meter.
- Ram stroke from 900 mm to 1.2 meters.
- Optional tilting headstock.
- Equipped with operator's cabin which moves both horizontally and vertically.
- Equipped with floor plates and/or rotary tables that can hold up to 100 metric tons.



18

see page

WRF 2G

WRF is FERMAT's large, robust series of floor-type horizontal boring mills, excellent for powerful and precise machining of enormous, heavy workpieces.

- Spindle diameter 150 mm or 160 mm; spindle travel 1000 mm.
- Ram stroke 1.5 meters.
- Rapid Travel Feed 40000 mm/min.
- X,Y, headstock motors are water-chilled – the heat is dissipated out of the machine to keep the machine geometry.
- Low-profile design – the highest possible Y axis travel with the lowest machine total height.



20

see page

WRF HEAVY

WRF Heavy is FERMAT's titan, monster-size floor-type horizontal boring mill. Its sturdy headstock is built between two columns for maximum stability.

- Spindle diameter 160 mm, spindle extension of 1 meter.
- Ram stroke of 1.5 or 1.6 meters.
- 4 servomotors and 4 rack and pinions are used for swift and smooth precise movement along Y axis.
- Equipped with floor plates and/or rotary tables that can hold up to 100 metric tons.
- Ideal for oversize workpieces.



22

see page

WFC 10



	Units	WFC 10	WFC 10 L
Diameter of Spindle	mm	100 / 110	
Taper of Spindle		ISO50 / BT50 / CAT50	
Max. Spindle Speed	rpm	3000 (optionally 4000)	
Main Power Heidenhain or SIEMENS CNC (S1/S6)	kW	19,5 / 29,3; 31 / 46,5	
Max. Torque Heidenhain or SIEMENS CNC (S1/S6)	Nm	951 / 1426; 1416 / 2124	
Main Power FANUC CNC (S1/S3)	kW	22 / 26; 30 / 37	
Max. Torque FANUC CNC (S1/S3)	Nm	823 / 971; 1370 / 1692	
X Cross Travel of Table	mm	1250 / 2000	
Y Vertical Travel of Headstock	mm	1250 / 1700 / 2000	1400 / 1850 / 2150
Z Longitudinal Travel of Column	mm	1250	1500
W Spindle Travel	mm	730	
Rapid Feed X, Y	mm/min	8000	14000 (optionally 30000)
Rapid Feed Z, W	mm/min	8000	14000 (optionally 30000), 8000
Rapid Feed B	rpm	2 (optionally 4)	2 (optionally 10)
Max. Table Load	kg	3000 / 5000	
Table Size	mm	1000 x 1120 / 1250 x 1400 / 1250 x 1800 / 1400 x 1600	

* A large number of accessories are available.

ACCESSORIES & DETAILS



HEADSTOCK



COLUMN



BEDS



CNC ROTARY TABLE

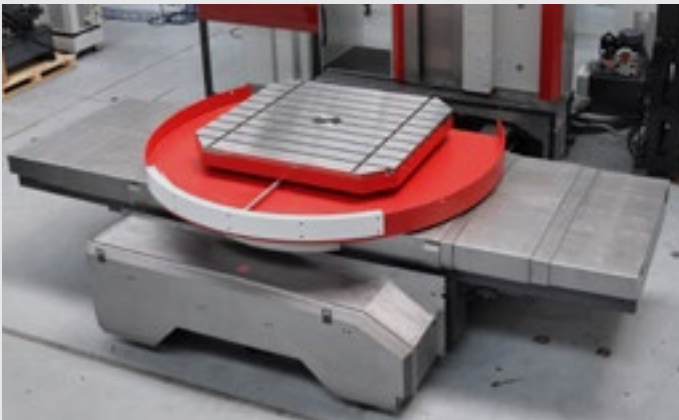

HEADSTOCK

Rugged, powerful, precise.

- The headstock is made from cast iron GGG60 and is equipped with a digitally-controlled servomotor turning the spindle, continuously regulating its rpm.
- Spindle travel (W axis) of 730 mm, driven by a servomotor and ball screw.
- Clamping spindle taper SK50 (ISO, BT, or CAT).
- Torque transferred to the spindle through a two-speed planetary gearbox. Gears change automatically according to the programmed rpm.
- Standard spindle support sleeve of 250 mm.

COLUMN

- Headstock carriage in a cast iron casting, provides movement of headstock in axis Y controlled by ball-screw and along box guideways.
- Guideways are lubricated by oil.

COLUMN AND BEDS

Rigid, tough, precise, designed to absorb vibrations during machining.

- The main framework of the machine (the longitudinal and crosswise beds, slides, and the column base) are made of cast iron GG30 with the addition of Cr and Cu; the functional surfaces of all the ways of the box guides is hardened (56 HRC) and ground.
- Servomotors and ball screws drive the CNC rotary table along X axis and Z axis, headstock on Y axis.
- Ball-screw on axis Y is equipped with an electric brake at the bottom.
- Separate servo drives on all axes, controlled digitally, provide the means for linear, circular, and helical interpolation.

CNC ROTARY TABLE

Thanks to the simple design and excellent components, FERMAT CNC rotary tables require minimum maintenance and adjustments during their lifetime.

- Maximum load is up to 5 tons.
- Rotary table moves along X and Z axis on box guideways or linear guideways.
- The CNC rotary table consists of three main parts – bed, slide, and rotary clamping plate. The clamping plate is fitted to a cross roller bearing that secures high load capacity, no stick slip, minimum friction.
- 2 servomotors with pinions provide the rotary movement on B axis, master/slave, no backlash.
- The rotary positioning of the table uses an absolute angle encoder (increment of 0.001°); the table is set in position, and held in place by hydraulic brakes.

WFT 11

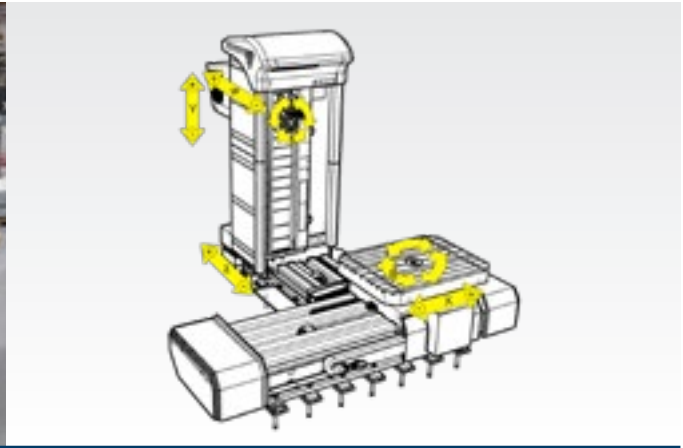

	Units	WFT 11
Diameter of Spindle	mm	100 / 110
Taper of Spindle		ISO50 / BT50 / CAT50
Max. Spindle Speed	rpm	3000 (optionally 4000)
Main Power Heidenhain or SIEMENS CNC (S1/S6)	kW	19,5 / 29,3; 31 / 46,5
Max. Torque Heidenhain or SIEMENS CNC (S1/S6)	Nm	951 / 1426; 1416 / 2124
Main Power FANUC CNC (S1/S3)	kW	22 / 26; 30 / 37
Max. Torque FANUC CNC (S1/S3)	Nm	823 / 971; 1370 / 1692
X Cross Travel of Table	mm	2000 / 3000
Y Vertical Travel of Headstock	mm	1250 / 1700 / 2000
Z Longitudinal Travel of Column	mm	1250 / 1700
W Spindle Travel	mm	730
Rapid Feed X, Y	mm/min	8000
Rapid Feed Z, W	mm/min	8000
Rapid Feed B	rpm	2 (optionally 4)
Max. Table Load	kg	10000 (for more options see page 24)
Table Size	mm	1200 x 1200 / 1200 x 1400 / 1400 x 1600 / 1400 x 1800 / 1600 x 1600 / 1600 x 1800

* A large number of accessories are available.

ACCESSORIES & DETAILS



HEADSTOCK



LIGHTING OF THE WORKING AREA



BEDS



MASTER - SLAVE SYSTEM



HEADSTOCK

Rugged, powerful, precise.

- The headstock is made from cast iron GGG60 and is equipped with a digitally-controlled servomotor turning the spindle, continuously regulating its rpm.
- Spindle travel (W axis) of 730 mm, driven by a servomotor and ball screw.
- Clamping spindle taper SK50 (ISO, BT, or CAT).
- Torque transferred to the spindle through a two-speed planetary gearbox. Gears change automatically according to the programmed rpm.
- Standard spindle support sleeve of 250 mm.

HEADSTOCK CARRIAGE

- Headstock carriage in a cast iron casting, provides movement of headstock in axis Y controlled by ball-screw and along box guideways.
- Guideways are lubricated by oil.

COLUMN AND BEDS

Rigid, tough, precise, designed to absorb vibrations during machining.

- The main framework of the machine (the longitudinal and cross-wise beds, slides, and the column base) are made of cast iron GG30 with the addition of Cr and Cu; the functional surfaces of all the ways of the box guides is hardened (56 HRC) and ground.
- Servomotors and ball screws drive the CNC rotary table along X axis, headstock on Y axis, and column along Z axis.
- Ball-screw on axis Y is equipped with an electric brake at the bottom.
- Separate servo drives on all axes, controlled digitally, provide the means for linear, circular, and helical interpolation.
- X, Y and Z axis are moving on hardened box guideways or wide linear guideways.

CNC ROTARY TABLE

Thanks to the simple design and excellent components, FERMAT CNC rotary tables require minimum maintenance and adjustments during their lifetime.

- Maximum load is up to 10 tons.
- The CNC rotary table consists of three main parts – bed, slide, and rotary clamping plate. The clamping plate is fit to a cross roller bearing that secures high load capacity, no stick slip, minimum friction.
- Slides and clamping plate are castings.
- 2 servomotors with pinions provide the rotary movement on B axis, master/slave, no backlash.
- The rotary positioning of the table uses an absolute angle encoder (increment of 0.001°); the table is set in position, and held in place by hydraulic brakes.

WFT 13

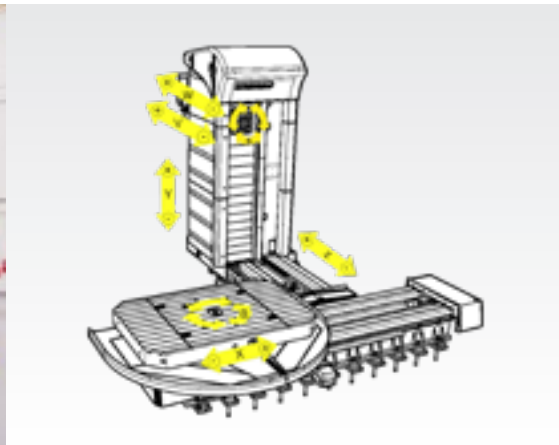

	Units	WFT 13	WFT 13R
Diameter of Spindle	mm	130	
Taper of Spindle		ISO50 / BT50 / CAT50 / BIG PLUS option	
Max. Spindle Speed	rpm	3000	
Main Power Heidenhain or SIEMENS CNC (S1/S6)	kW	41 / 61,5; 53 / 77,9	
Max. Torque Heidenhain or SIEMENS CNC (S1/S6)	Nm	2099 / 3149; 2713 / 3989	
Main Power FANUC CNC (S1/S3)	kW	37 / 45; 53 / 62	
Max. Torque FANUC CNC (S1/S3)	Nm	2362 / 2873; 2713 / 3989	
X Cross Travel of Table	mm	2000 / 3000 / 4000 / 5000	
Y Vertical Travel of Headstock	mm	2000 / 2500 / 3000 / 3500 / 4000	
Z Longitudinal Travel of Column	mm	1500 / 2000 / 2500 / 3000	
W Spindle Travel	mm	800	
V Ram Travel	mm	x	700
Rapid Feed X, Y	mm/min	15000, 12000	
Rapid Feed Z, W, V	mm/min	8500, 10000, 12000	
Rapid Feed B	rpm	2 (optionally 5)	
Max. Table Load	kg	20000 (for more options see page 24)	
Table Size	mm	1600 x 1800 / 1800 x 2200 / 1800 x 2600 / 2000 x 2400 / 2500 x 2500 / 2000 x 3000	

* A large number of accessories are available.

ACCESSORIES & DETAILS



STANDARD HEADSTOCK



RAM EXECUTION



BEDS



CNC ROTARY TABLE



STANDARD HEADSTOCK

Rugged, powerful, precise.

- The headstock is made from cast iron GGG60 and is equipped with a digitally-controlled servomotor turning the spindle, continuously regulating its rpm.
- Spindle travel (W axis) of 800 mm, driven by a servomotor and ball screw.
- Clamping spindle taper SK50 (ISO, BT, or CAT).
- Torque transferred to the spindle through a two-speed planetary gearbox. Gears change automatically according to the programmed rpm.
- Standard spindle support sleeve of 250 mm.

RAM EXECUTION (OPTIONAL)

The headstock moves up to 700 mm towards the workpiece.

- Combined reach of spindle travel and ram stroke maximum 1500 mm.
- Ram stroke drives deep into the heart of the workpiece while maintaining the highest rigidity and accuracy.
- Ram stroke is controlled by servomotor with gearbox and ball-screw.
- All deflections compensated through different mechanical features of ram and headstock.

COLUMN AND BEDS

Rigid, tough, precise, designed to absorb vibrations during machining.

- Column frame, beds, slides, base, are made of reinforced cast iron GG30.
- Maximum rigidity and firmness of column and bed achieved through annealing; guideways and box ways hardened (56 HRC).
- Servomotors and ball screws (80 mm in diameter) drive the CNC rotary table along X axis, headstock on Y axis, and column along Z axis.
- Y axis servomotor is equipped with mechanical brake.
- Separate servo drives on all axes, controlled digitally, provide the means for linear, circular, and helical interpolation.

CNC ROTARY TABLE

Thanks to the simple design and excellent components, FERMAT CNC rotary tables require minimum maintenance and adjustments during their lifetime.

- Standard load is up to 20 tons. Please see more options on page 24.
- The CNC rotary table consists of three main parts – bed, slide, and rotary clamping plate. The clamping plate is fit to a cross roller bearing that secures high load capacity, no stick slip, minimum friction.
- Slides and clamping plate are castings.
- 2 servomotors with pinions provide the rotary movement on B axis, master/slave, no backlash.
- The rotary positioning of the table uses an absolute angle encoder (increment of 0.001°); the table is set in position, and held in place by hydraulic brakes.
- With linear option X, Y and Z axis move on linear ways.

WFT 15

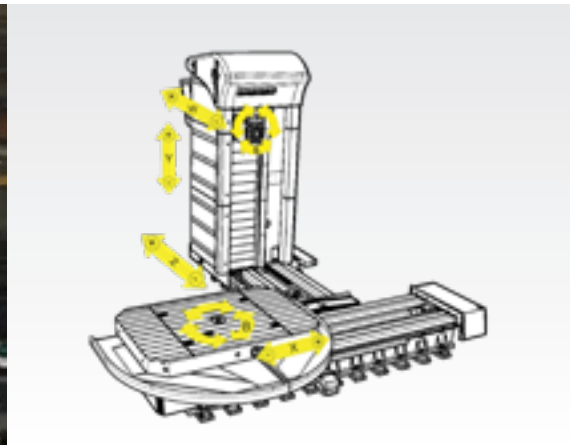

	Units	WFT 15 / WFT 15R	WFT 15-1000
Diameter of Spindle	mm	150	
Taper of Spindle		ISO50 / BT50 / CAT50 / BIG PLUS option	
Max. Spindle Speed	rpm	2800	
Main Power Heidenhain or SIEMENS CNC (S1/S6)	kW	41 / 61,5; 53 / 77,9	58 / 88
Max. Torque Heidenhain or SIEMENS CNC (S1/S6)	Nm	2099 / 3149; 2713 / 3989	2625 / 3990
Main Power FANUC CNC (S1/S3)	kW	37 / 45; 53 / 62	60 / 75
Max. Torque FANUC CNC (S1/S3)	Nm	2362 / 2873; 2713 / 3989	2263 / 2829
X Cross Travel of Table	mm	2000 / 3000 / 4000 / 5000	
Y Vertical Travel of Headstock	mm	2000 / 2500 / 3000 / 3500	
Z Longitudinal Travel of Column	mm	1500 / 2000	2100 / 3300
W Spindle Travel	mm	800	1000
V Ram Travel	mm	x / 700	x
Rapid Feed X, Y	mm/min	12000	12000
Rapid Feed Z, W, V	mm/min	8500, 10000, 12000	
Rapid Feed B	rpm	2 (optionally 5)	
Max. Table Load	kg	20000 (for more options see page 24)	
Table Size	mm	1600 x 1800 / 1800 x 2200 / 1800 x 2600 / 2000 x 2400 / 2000 x 3000 / 2500 x 2500	

* A large number of accessories are available.

ACCESSORIES & DETAILS



RAM EXECUTION



HEADSTOCK WITH SPINDLE TRAVEL 1000 MM



BEDS



CNC ROTARY TABLE WITH PALLET CHANGE SYSTEM



HEADSTOCK WITH SPINDLE TRAVEL 1000 mm

Powerful headstock with long spindle extension.

- The headstock is made from cast iron GGG60 and is equipped with a digitally-controlled servomotor turning the spindle, continuously regulating its rpm.
- Spindle travel (W axis) of 1000 mm, driven by a servomotor and ball screw.
- Clamping spindle taper SK50 (ISO, BT, or CAT).
- Torque transferred to the spindle through a two-speed planetary gearbox. Gears change automatically according to the programmed rpm.
- Standard spindle support sleeve of 250 mm.

RAM EXECUTION (OPTIONAL)

The headstock moves up to 700 mm towards the workpiece. Spindle Travel 800 mm.

- Combined reach of spindle travel and ram stroke maximum 1430 mm (optionally 1500 mm).
- Ram stroke drives deep into the heart of the workpiece while maintaining the highest rigidity and accuracy.
- Ram stroke is controlled by servomotor with gearbox and ball-screw.
- All deflections compensated through geometric features of ram and headstock.

COLUMN AND BEDS

Rigid, tough, precise, designed to absorb vibrations during machining.

- Column frame, beds, slides, base, are made of reinforced cast iron GG30.
- Maximum rigidity and firmness of column and bed achieved through annealing; guideways and box ways hardened (56 HRC).
- Servomotors and ball screws (80 mm in diameter) drive the CNC rotary table along X axis, headstock on Y axis, and column along Z axis.
- Y axis servomotor is equipped with mechanical brake.
- Separate servo drives on all axes, controlled digitally, provide the means for linear, circular, and helical interpolation.

CNC ROTARY TABLE

Thanks to the simple design and excellent components, FERMAT CNC rotary tables require minimum maintenance and adjustments during their lifetime.

- Standard load is up to 20 tons. Please see more options on page 24.
- The CNC rotary table consists of three main parts – bed, slide, and rotary clamping plate. The clamping plate is fit to a cross roller bearing that secures high load capacity, no stick slip, minimum friction.
- Slides and clamping plate are castings.
- 2 servomotors with pinions provide the rotary movement on B axis, master/slave, no backlash.
- The rotary positioning of the table uses an absolute angle encoder (increment of 0.001°); the table is set in position, and held in place by hydraulic brakes.



	Units	WF 13R	WF 15R
Diameter of Spindle	mm	130	150
Taper of Spindle		ISO50 / BT50 / CAT50 / BIG PLUS option	
Max. Spindle Speed	rpm	3000 (optionally 4000)	2800
Main Power Heidenhain or SIEMENS CNC (S1/S6)	kW	41 / 61,5; 53 / 77,9	
Max. Torque Heidenhain or SIEMENS CNC (S1/S6)	Nm	2099 / 3149; 2713 / 3989	
Main Power FANUC CNC (S1/S3)	kW	37 / 45; 53 / 62	
Max. Torque FANUC CNC (S1/S3)	Nm	2362 / 2873; 2713 / 3989	
X Cross Travel of Column	mm	4000 – 22000	
Y Vertical Travel of Headstock	mm	2000 / 2500 / 3000 / 3500	
Z Ram Travel	mm	700	
W Spindle Travel	mm	800	
Rapid Feed X, Y	mm/min	20000, 12000	
Rapid Feed Z, W	mm/min	12000, 10000	
Rotary Table - Optional Accessory			
Max. Table Load	kg	20000 (for more options see page 24)	
Table Size	mm	1600 x 1800 / 1800 x 2200 / 1800 x 2600 / 2000 x 2400	
V Longitudinal Travel of Table	mm	2000 – 3000	
Rapid Feed V-Axes	mm/min	12000	
Rapid Feed B-Axes	rpm	2 (optionally 5)	

* A large number of accessories are available.

ACCESSORIES & DETAILS



HEADSTOCK



RAM EXECUTION

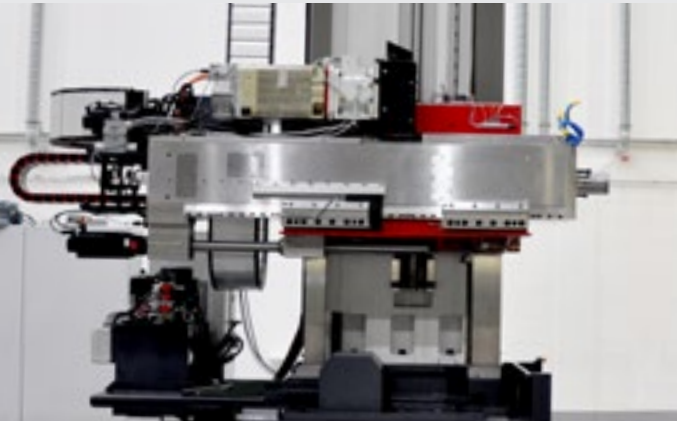

BEDS



CNC ROTARY TABLE



STANDARD HEADSTOCK

Rugged, powerful, precise.

- The headstock is made from cast iron GGG60 and is equipped with a digitally-controlled servomotor turning the spindle, continuously regulating its rpm.
- Spindle travel (W axis) of 800 mm, driven by a servomotor and ball screw.
- Clamping spindle taper SK50 (ISO, BT, or CAT).
- Torque transferred to the spindle through a two-speed planetary gearbox. Gears change automatically according to the programmed rpm.
- Standard spindle support sleeve of 250 mm.

RAM EXECUTION (OPTIONAL)

The headstock moves up to 700 mm towards the workpiece.

- Combined reach of spindle travel and ram stroke maximum 1430 mm (optionally 1500 mm).
- Ram stroke drives deep into the heart of the workpiece while maintaining the highest rigidity and accuracy.
- Ram stroke is controlled by servomotor with gearbox and ball-screw.
- All deflections compensated through geometric features of ram and headstock.

COLUMN AND BEDS

Rigid, tough, precise, designed to absorb vibrations during machining.

- Column frame, beds, slides, base, are made of reinforced cast iron GG30.
- Maximum rigidity and firmness of column and bed achieved through annealing; guideways and box ways hardened (56 HRC).
- Servomotors and ball screws (80 mm in diameter) drive the CNC rotary table along X axis, headstock on Y axis, and column along Z axis.
- Y axis servomotor is equipped with mechanical brake.
- Separate servo drives on all axes, controlled digitally, provide the means for linear, circular, and helical interpolation.

CNC ROTARY TABLE AND CLAMPING PLATES

Thanks to the simple design and excellent components, FERMAT CNC rotary tables require minimum maintenance and adjustments during their lifetime.

- The CNC rotary table consists of three main parts – bed, slide, and rotary clamping plate. The clamping plate is fit to a cross roller bearing that secures high load capacity, no stick slip, minimum friction.
- Slides and clamping plate are castings.
- 2 servomotors with pinions provide the rotary movement on B axis, master/slave, no backlash.
- The rotary positioning of the table uses an absolute angle encoder (increment of 0.001°); the table is set in position, and held in place by hydraulic brakes.
- Clamping plates can be used for machining parts.

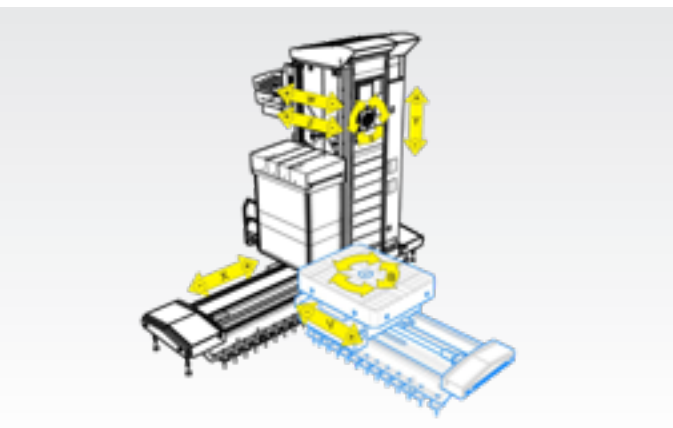

	Units	WRF 130 CNC	WRF 150 CNC	WRF 160 CNC
Diameter of Spindle	mm	130	150	160
Taper of Spindle		ISO50 / BT50 / CAT50 / BIG PLUS option		
Max. Spindle Speed	rpm	3000 (optionally 4000)	2800 (optionally 3500)	2500 (optionally 3200)
Main Power Heidenhain or SIEMENS CNC (S1/S6)	kW	41 / 61,5; 53 / 77,9		58 / 86; 74 / 109
Max. Torque Heidenhain or SIEMENS CNC (S1/S6)	Nm	2099 / 3149; 2713 / 3989		3281 / 4988; 3349 / 4923
Main Power FANUC CNC (S1/S3)	kW	37 / 45; 53 / 62		60 / 75
Max. Torque FANUC CNC (S1/S3)	Nm	2362 / 2873; 2713 / 3989		2829 / 3536
X Cross Travel of Column	mm	1800 – 27500		
Y Vertical Travel of Headstock	mm	2500 / 3000 / 3500 / 4000 / 4500 / 5000 / 5500 / 6000		
Z Ram Travel	mm	1000		1200
W Spindle Travel	mm	800		1000
Rapid Feed X, Y	mm/min	20000 (optionally 40000), 15000 (optionally 24000)		
Rapid Feed Z, W	mm/min	10000, 8000		10000 (optionally 24000), 10000

Rotary Table – Optional Accessory

Max. Table Load	kg	T25 – 25000 / T40 – 40000 / T50 – 50000 / T60 – 60000 / T80 – 80000 / T100 – 100000		
Table Size	mm	see page 24 / option tilting tables with 0 – 8°		

* A large number of accessories are available.

ACCESSORIES & DETAILS

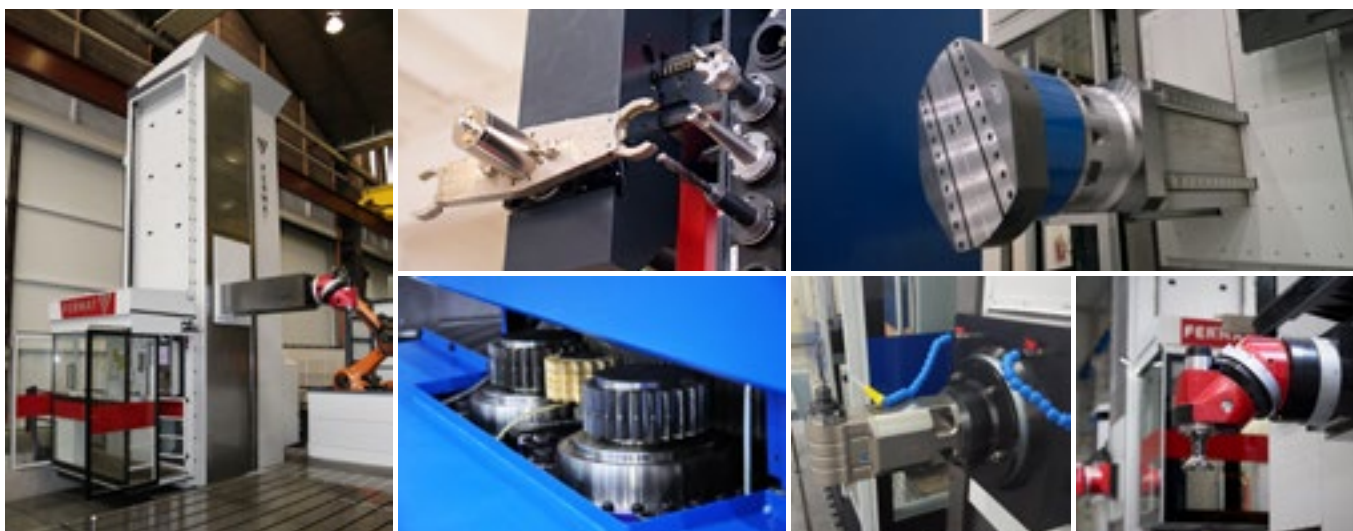

HEADSTOCK WITH RAM STROKE



COLUMN



BEDS



CNC ROTARY TABLE AND CLAMPING PLATES



HEADSTOCK WITH RAM STROKE

Rugged, powerful, precise.

- The headstock is made from cast iron GGG60 and is equipped with a digitally-controlled servomotor turning the spindle, continuously regulating its rpm.
- Spindle travel (W axis) of 800 mm (V130) and 1000 mm (V150, V160), driven by a servomotor and ball screw.
- Clamping spindle taper SK50 (ISO, BT, CAT or optionally BIG PLUS).
- Maximum ram stroke is 900 (V130) and 1200 mm (V150, V160). Ram stroke offers better access to work-piece while keeping rigidity.
- Ram stroke is controlled by servomotor with gear-box and ball-screw, on linear motion (LM) guideways.

COLUMN AND BEDS

Rigid, tough, precise, designed to absorb vibrations during machining.

- Column frame, beds, slides, base, are made of reinforced cast iron GG30.
- Column is a massively constructed weldment. Maximum stiffness is achieved through annealing which leads to rigidity and firmness in metal-working procedures. Guideways and box ways are hardened (56 HRC).
- Movement of the headstock along the Y axis is achieved by multiple ball-screws - two (for V130, \varnothing 100 mm, 2 brakes) / three ball-screws (for V150/160, \varnothing 80 mm, one brake) with gear-boxes and servomotors.
- Column moves by rack and pinion drive on the X axis bed using large linear ways and carriages driven by 2 servomotors in (MASTER-SLAVE) configuration.
- Two linear positioning scales are also placed on column to further increase precision of the ram.

CNC ROTARY TABLE AND CLAMPING PLATES

Thanks to the simple design and excellent components, FERMAT CNC rotary tables require minimum maintenance and adjustments during their lifetime.

- The CNC rotary table consists of three main parts - bed, slide, and rotary clamping plate. The clamping plate is fit to a cross roller bearing that secures high load capacity, no stick slip, minimum friction.
- Table carriage moves on 2 linear motion (LM) guideways.
- For tables with travel of up to 5 meters, the travel is controlled by servomotor with planetary gear-box and ball-screw.
- Slides and clamping plate are castings.
- 2 servomotors with pinions provide the rotary movement on B axis, master/slave, no backlash.
- The rotary positioning of the table uses an absolute angle encoder (increment of 0.001°); the table is set in position, and held in place by hydraulic brakes.
- Clamping plates can be used for machining parts.

WRF 2G

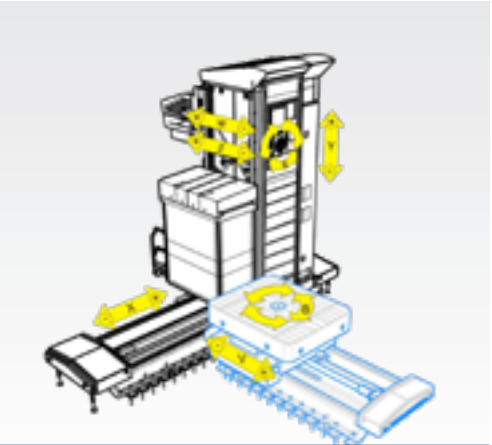

	Units	WRF 2G		
--	-------	--------	--	--

Diameter of Spindle	mm	150	160	180
Taper of Spindle		ISO50 / BT50 / CAT50 / BIG PLUS option		
Max. Spindle Speed	rpm	3000 (optionally 3500)		2500
Main Power CNC SIEMENS (S1/S6-40%)	kW	72 / 106		
Max. Torque SIEMENS CNC (S1/S6-40%)	Nm	3294 / 4843		5000 / 7350
Main Power FANUC (S1/S3)	kW	60 / 75		on request
Max. Torque FANUC CNC (S1/S3)	Nm	2829 / 3536		on request
X Cross Travel of Column	mm	1800 – 27500		
Y Vertical Travel of Headstock	mm	2500 / 3000 / 3500 / 4000 / 4500 / 5000 / 5500 / 6000		
W Spindle Travel	mm	1000		
Z Ram Travel	mm	1500		
Rapid Feed X, Y	mm/min	40000, 15000		
Rapid Feed Z, W	mm/min	10000		

Rotary Table – Optional Accessory

Max. Table Load	kg	T25 – 25000 / T40 – 40000 / T50 – 50000 T60 – 60000 / T80 – 80000		
Table Size	mm	see page 24 / option tilting tables with 0 – 8°		

* A large number of accessories are available.

ACCESSORIES & DETAILS



STANDARD HEADSTOCK



TILTING HEADSTOCK



COLUMN



CNC TILTING TABLE



The new WRF series – thousands of machining hours experience for your workshop.

HIGHER DYNAMICS

- Rapid travel feed 40000 mm/min.
- Special telescopic way covers for high speed travels.
- Linear ways are lubricated with oil. A thin oil layer is cleaning the linear guideways which is a big advantage for machining of castings.

SPECIAL DESIGN OF COLUMN

- 2x ballscrews 100 mm with two absolute scales.
- Full covers from the front and the back side.
- Low-profile design – the highest possible Y-Axis travel with the lowest machine total height.

ADVANCED TEMPERATURE STABILIZATION

- X,Y, headstock motors are water-chilled – the heat is dissipated out of the machine to maintain geometry stabilization.
- Reduction of heat accumulation in the column.
- Reduction of dust in the column.
- Better headstock chilling for longer lifetime of bearings.
- 2 recirculating chilled circuits of the headstock.
- Chilling of material surrounding the bearings from the outer diameter and prevents the heat from affecting the RAM.
- Chilling mixture of oil and air which is brought to the main bearings to lubricate them. The mixture is then sucked out of the bearings together with the unnecessary heat.
- Important prolongation of bearings lifetime since the special mixture of oil has a smaller degree of viscosity and thus creates lower temperatures.

THE BEST WE CAN BUILD FOR YOU

- Standard 3000 rpm for spindle diameter 150 / 160 mm or optionally 3500 rpm for spindle diameter 150 / 160 mm. 2500 rpm for spindle diameter 180 mm.
- Standard 58 kW or optionally 72 kW water-chilled motor from Siemens.
- Moveable cabin horizontally (800 mm) + vertically (according to the Y-Travel).
- 2 independent mechanisms for spindle fall compensation:
- Y axis positioning is managed by 2 ball-screws with Heidenhain absolute linear scales.
- Hydraulic torsion bars are used for ram stiffness stabilization.

WRF HEAVY

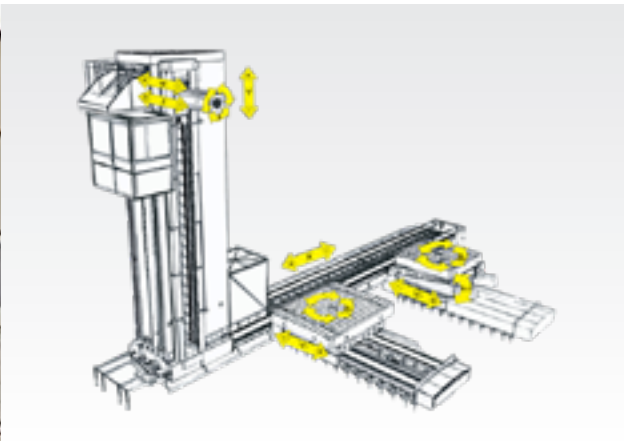

	Units	WRF 160 Heavy
Diameter of Spindle	mm	160
Taper of Spindle		ISO50 / BT50 / CAT50 / BIG PLUS option
Max. Spindle Speed	rpm	2500
Main Power Heidenhain or SIEMENS CNC (S1/S6)	kW	74 / 91
Max. Torque Heidenhain or SIEMENS CNC (S1/S6)	Nm	3349 / 4120
X Cross Travel of Column	mm	2400 – 28100
Y Vertical Travel of Headstock	mm	2000 – 10000
Z Ram Travel	mm	1600
W Spindle Travel	mm	1000
Rapid Feed X, Y	mm/min	20000, 15000
Rapid Feed Z, W	mm/min	15000, 10000
Rotary Table – Optional Accessory		
Max. Table Load	kg	T25 – 25000 / T40 – 40000 / T50 – 50000 / T80 – 80000 / special T60 – 60000
Table Size	mm	see page 24 / option tilting tables with 0 - 8°
V Longitudinal Travel of Table	mm	2000 – 5000 2400 – 9500 and special
Rapid Feed V-Axes	mm/min	12000 20000
Rapid Feed B-Axes	rpm	1,7

* A large number of accessories are available.

ACCESSORIES & DETAILS



HEADSTOCK



HEADSTOCK CARRIAGE

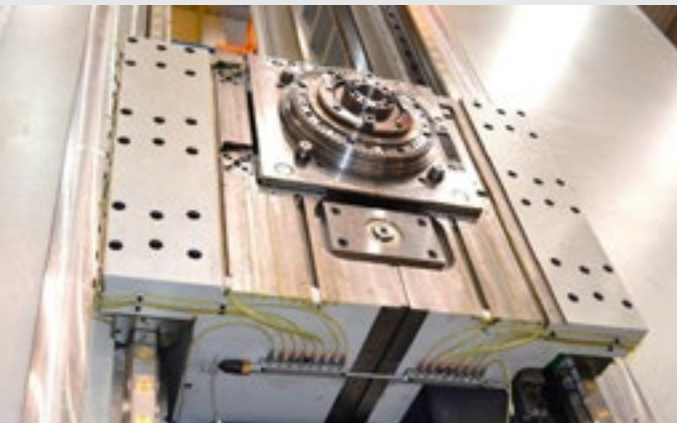

LM ROLLER GUIDEWAYS



HYDROSTATIC GUIDEWAYS



HEADSTOCK WITH RAM STROKE

Headstock "ram" is designed with the latest world trends in machine tool design and is prepared to accept manual and automatic attachment heads, face plates, etc.

- Iron casting GGG60 of the main carrier of the headstock (ram) is prism-shaped and has a massive square profile of 550 x 550.
- Headstock and carriage are situated between two columns for better stability.
- Maximum ram stroke is 1600 mm. Ram stroke offers better access to workpiece while keeping rigidity.
- The travel of the headstock is provided by six hardox hardened slideways.
- Extra linear guideway is added for stabilization of the saddle.
- Spindle travel (W axis) of 1000 mm driven by a servomotor and ball screw.

COLUMN AND BEDS

Rigid, tough, precise, designed to absorb vibrations during machining.

- Column frame, beds, slides, base, are made of reinforced cast iron GG30.
- Column is a massively constructed weldment. Maximum stiffness is achieved through annealing which leads to rigidity and firmness in metal-working procedures.
- Column moves by rack and pinion drive on the X axis bed using large linear ways and carriages driven by 2 servomotors in (MASTER-SLAVE) configuration.
- Two linear positioning scales are also placed on column to further increase precision of the ram.

CNC ROTARY TABLE AND CLAMPING PLATES

Thanks to the simple design and excellent components, FERMAT CNC rotary tables require minimum maintenance and adjustments during their lifetime.

- The CNC rotary table consists of three main parts – bed, slide, and rotary clamping plate. The clamping plate is fit to a cross roller bearing that secures high load capacity, no stick slip, minimum friction.
- Table carriage moves on 2 linear motion (LM) guideways.
- For tables with travel of up to 5 meters, the travel is controlled by servomotor with planetary gear-box and ball-screw.
- Slides and clamping plate are castings.
- 2 servomotors with pinions provide the rotary movement on B axis, master/slave, no backlash.
- The rotary positioning of the table uses an absolute angle encoder (increment of 0.001°); the table is set in position, and held in place by hydraulic brakes.
- Clamping plates can be used for machining parts.

SPECIAL ACCESSORIES

Rotary Table

All the tables have outstanding positioning precision (4 arc sec. 0.010 mm / 1000 mm radius). There is no slip-stick during the positioning of the table. Due to simple design and assembled components, FERMAT tables require minimum maintenance and adjustments during their lifetime.

The rotary table consists of bed, slide, and rotary clamping plate. The slide enables the rotary clamping plate to move in the V-axis. The clamping plate is fitted onto a cross roller bearing that secures high load capacity with minimal pas-

sive resistance. In order to achieve precision in work pieces, the rotary table is hydraulically clamped at four points (T10, T20), eight points (T25, T40, T50) or 12 points (T80, T100) to avoid rotation during the working process.

The table is governed by the control system of the machine, and there is a rotary encoder in the centre of the table that facilitates the automatic positioning in increments of 0.001°. As a standard, the rotary table operates as a continuous 4th axis.

T10		
Clamping Plate Size (mm)	1250 x 1400, 1400 x 1600, 1600 x 1600, 1600 x 1800	
Max. Table Load (kg)	10000	
Table Travel (mm)	2000 - 3000	
T-Slots Size	22H8	
Operation Travel V-Axis (mm/min)	1 - 8000	
Operation Travel B-Axis (rpm)	2 (optionally 10)	
T20		
Clamping Plate Size (mm)	1600 x 1800, 1800 x 2200, 1800 x 2600, 2000 x 2400, 2500 x 2500, 2000 x 3000	
Max. Table Load (kg)	20000	
Table Travel (mm)	2000 - 5000	
T-Slots Size	22H8 (optionally 28H8)	
Operation Travel V-Axis (mm/min)	1 - 8000	
Operation Travel B-Axis (rpm)	2 (optionally 5)	
T25 / T40 / T50		T80 / T100
Clamping Plate Size (mm)	2000 x 2000, 2000 x 2500, 2500 x 2500, 2500 x 3000, 3000 x 3000, 3000 x 3500, 3500 x 3500	3000 x 3000, 3000 x 3500, 3000 x 4000, 4000 x 4000
Max. Table Load (kg)	25000, 40000, 50000	80000, 100000
Table Travel (mm)	1200 - 9500	
T-Slots Size	28H8 (optionally 36H8)	
Operation Travel V-Axis (mm/min)	1 - 10000	
Operation Travel B-Axis (rpm)	0 - 1,7	
Tilting Angle (degrees)	x	0 - 10°

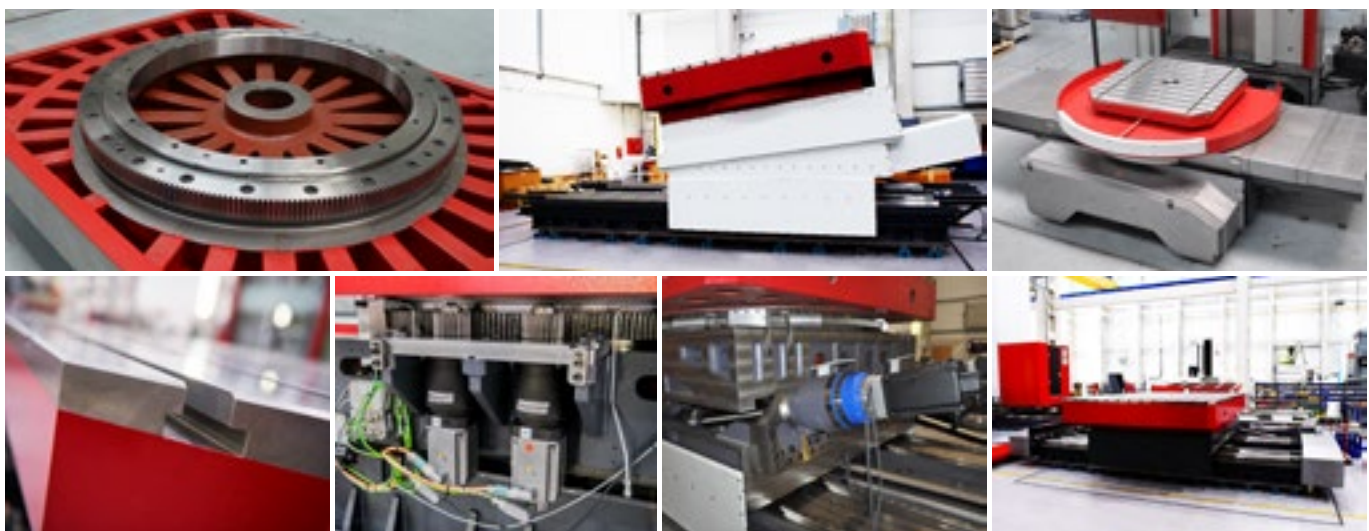

ZERO POINT SYSTEM

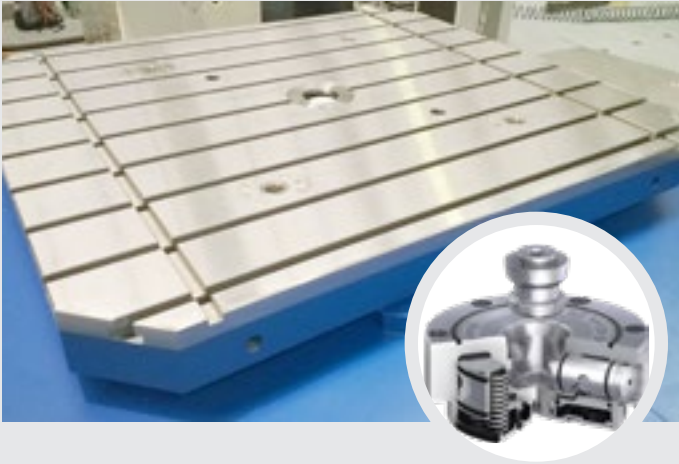

APC TYPE: AUTOMATIC SHUTTLE SYSTEM



APC TYPE: ROTARY



APC TYPE: AUTOMATIC PALLET CHANGER



Pallet Change System

Automatic pallet changer (APC) on the machine reduces unproductive time during machining. Machining can be carried out on one pallet, while the others can be used for preparation (cleaning of table, set up of work-piece).

ZERO POINT SYSTEM

Pallet clamping system at zero point. To clamp the device on the table, built-in modules are provided. The number of removable pallets is not limited.

- The pin is kept in position by two pistons.
- The pistons clamp the pin by the power of eight springs.
- The pistons are released pneumatically.
- Suitable for all types of Fermat machines.

APC TYPE: AUTOMATIC SHUTTLE SYSTEM

- 2 tables installed on one bed – the X axis.
- Max. load of one table: up to 40 tons.

Tables Dimensions:

1200 x 1200 mm up to 3000 x 3000 mm

APC TYPE: ROTARY

- Rotary system. 2 pallets installed on one additional bed.
- Max. load of one pallet: 5 tons.

Pallets Dimensions:

1200 x 1200 mm

1200 x 1400 mm

1400 x 1600 mm

APC TYPE: AUTOMATIC PALLET CHANGER

- 2 pallets are perpendicular to the X axis, each on its own bed.
- Max. load of one pallet: 15 tons.

Pallets Dimensions:

1600 x 1800 mm

1800 x 2200 mm

2000 x 2400 mm

Milling Heads



All milling heads (from 30 kW up) are designed and manufactured by FERMAT and therefore it determines their high quality as well as favorable service times, since Fermat has also its own warehouse of spare parts. As a part of Fermat head assembly shop there is an offer of spare milling heads. They are offered within Fermat excellent customer service to those customers, whose heads are currently being serviced (whether because of crash or routine maintenance).

Manual Milling Heads Up to 3000 RPM

Suitable for Machines with spindle diameter 130 mm and bigger.

UHM 30

Universal Manual Head UHM 30

Manually attached to the headstock, manual positioning, automatic tool clamping and unclamping.

Revolutions: 3000 rpm

Maximum Power: 30 kW

Maximum Torque (150 rpm): 1600 Nm

Tool: ISO 50 – DIN 69871

Pull Stud: DIN 69872

Turning: any degree (2,5° / 2,5° (1° / 1°))

Coolant Through Spindle: optional for machines with spindle diameter 130 / 150 / 160 mm.

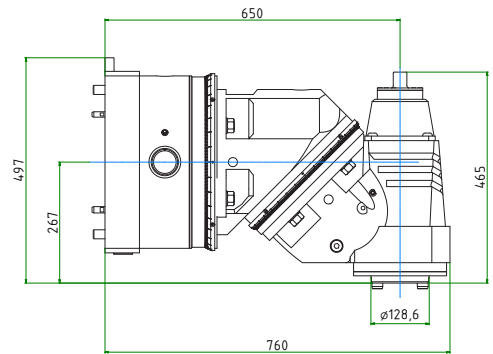

PHM 37

Right Angle Manual Head PHM 37

Manually attached to the headstock, manual positioning, automatic tool clamping and unclamping.

Revolutions: 3000 rpm

Maximum Power: 37 kW

Maximum Torque (150 rpm): 2000 Nm

Tool: ISO 50 – DIN 69871

Pull Stud: DIN 69872

Turning: any degree, 2,5° (1°)

Coolant Through Spindle: option for machines with spindle diameter 130 / 150 / 160 mm.

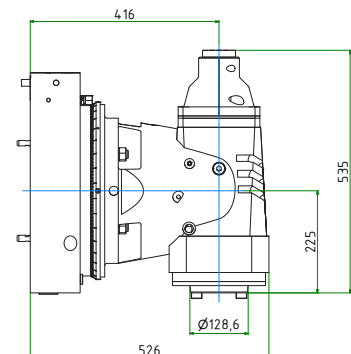

Manual Milling Heads Up to 2000 RPM

Suitable for Machines with spindle diameter up to 130 mm.

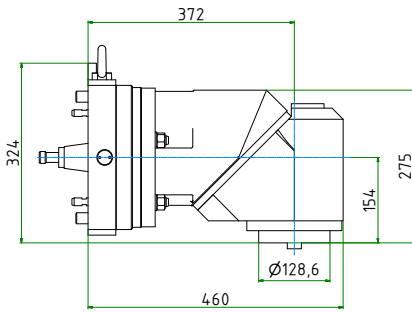

UHM 20

Two Axis Universal Manual Milling Head
Manually attached to the headstock, manual positioning, manual tool clamping and unclamping.

Revolutions: 2000 rpm

Maximum Power: 20 kW

Max. Torque: 1000 Nm

Tool: SK 50

Cooling Through Spindle: not possible

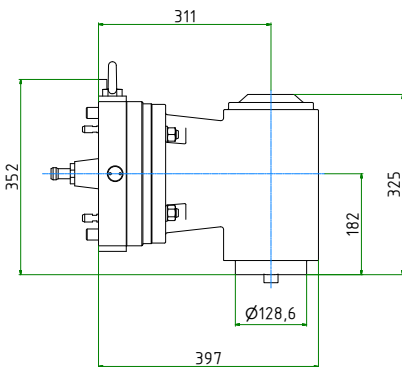

PHM 20

Right Angle Manual Milling Head
Manually attached to the headstock, manual positioning, manual tool clamping and unclamping.

Revolutions: 2000 rpm

Maximum Power: 20 kW

Max. Torque: 1000 Nm

Tool: SK 50

Cooling Through Spindle: not possible

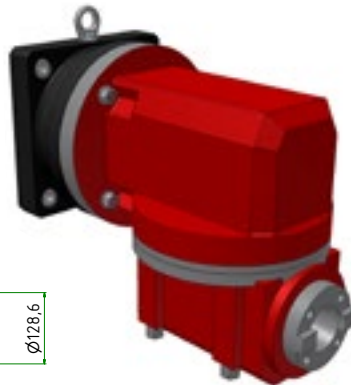
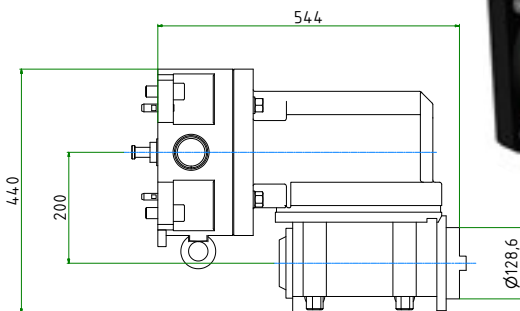

OHM 20

Two Axis Orthogonal Manual Milling Head
Manually attached to the headstock, manual positioning, manual tool clamping and unclamping.

Revolutions: 2000 rpm

Maximum Power: 20 kW

Max. Torque: 1000 Nm

Tool: SK 50

Cooling Through Spindle: not possible



Automatic Universal Milling Heads

UHA 0.001°

Universal Automatic Micro-Indexing Milling Head

Fully Automatic (attachment to the headstock, tool clamping, positioning, lubrication).

Revolutions: 10 – 3000 (option 4000) rpm

Max. Power: 53 kW

Maximum Torque: 1600 Nm

Spindle Taper: SK 50

Clamping Force of Tool (kN): 20±15%

Stall Torque in Axis A: brake 3800

Stall Torque in Axis C: brake 6500

Indexing: 0,001°

External Tool Coolant: standard

Coolant Trough Spindle: standard 80

Lubrication: automatic, grease

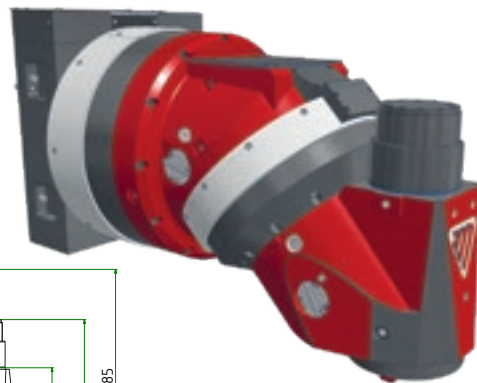
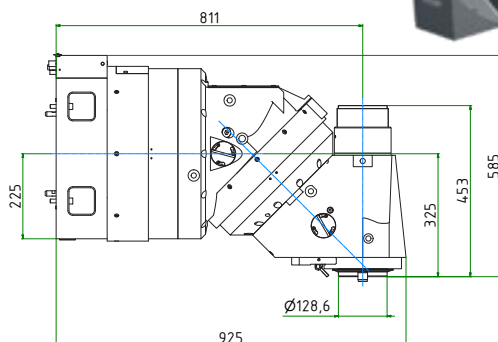

UHAmi SDHS

Universal Automatic Milling Head High Speed

Fully Automatic (attachment to the headstock, tool clamping, positioning, lubrication).

Positioned by the means of 2 x 2 servomotors (in MASTER-SLAVE preloading), enables continuous machining.

Revolutions: 10 – 5000 rpm

Max. Power: 41 kW

Maximum Torque: 1500 Nm

Spindle Taper: SK 50

Clamping Force of Tool (kN): 20±15%

Stall Torque in Axis A: brake 3370

Stall Torque in Axis C: brake 7811

Indexing: 0,001°

External Tool Coolant: standard

Coolant Trough Spindle: standard 80

Lubrication: automatic, oil

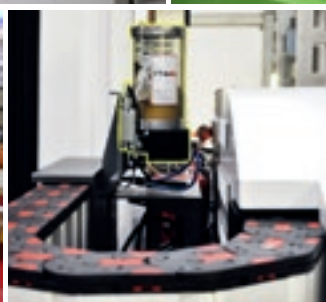
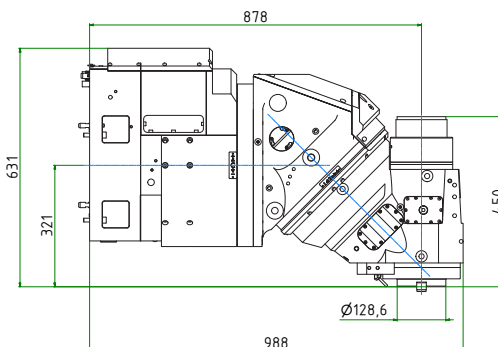

Automatic Right Angle Milling Heads

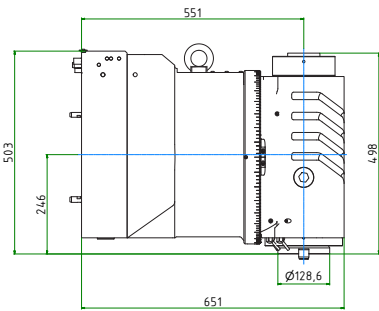

PHA 37

Right Angle Automatic Milling Head
Fully Automatic (attachment to the headstock, tool clamping, positioning, lubrication).

Revolutions: 10 – 3000 rpm

Max. Power: 37 kW

Maximum Torque: 2000 Nm

Spindle Taper: SK 50

Clamping Force of Tool (kN): 20±15%

Stall Torque in Axis C: hirth

Indexing: 2,5°

External Tool Coolant: standard

Coolant Trough Spindle: standard 30

Lubrication: automatic, grease

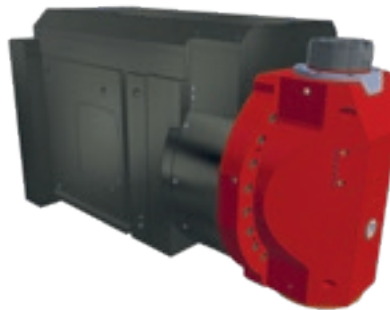
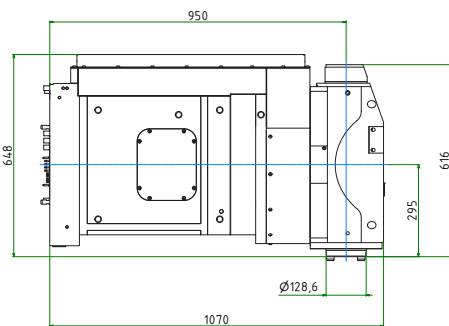

PHAmi 60 (0.001°)

Right Angle Automatic Milling Head
Fully Automatic (attachment to the headstock, tool clamping, positioning, lubrication).

Revolutions: 10 – 1700 rpm

Max. power: 74 kW

Maximum Torque: 3200 Nm

Spindle Taper: SK 50

Clamping Force of Tool (kN): 20±15%

Stall Torque in Axis C: brake 10 000

Indexing: 0.001°

External Tool Coolant: standard

Coolant Trough Spindle: standard 80

Lubrication: automatic, oil

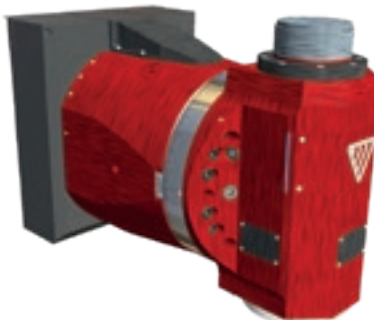
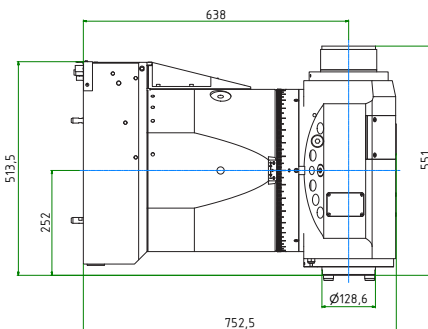

PHAmi 60 (1°)

Right Angle Automatic Milling Head
Fully Automatic (attachment to the headstock, tool clamping, positioning, lubrication).

Revolutions: 10 – 1700 rpm

Max. Power: 74 kW

Maximum Torque: 3200 Nm

Spindle Taper: SK 50

Clamping Force of Tool (kN): 20±15%

Stall Torque in Axis C: hirth

Indexing: 1°

External Tool Coolant: standard

Coolant Trough Spindle: standard 80

Lubrication: automatic, grease



Special Milling Heads

OMG TA 26

Right Angle Milling Head

Manually attached to the headstock, manual positioning, manual tool clamping and unclamping.

Revolutions: 1 – 2500 rpm max.

Maximum Power: 55 kW

Maximum Torque (150 rpm): 2600 Nm

Tool: SK 40

Coolant Through Spindle: not possible

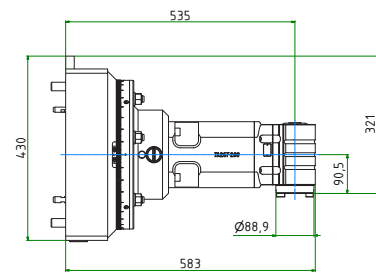
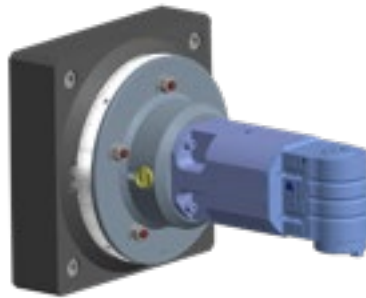

Alberti T90 – 10

Right Angle Milling Head

Manually or automatically attachment to the headstock, manual tool clamping and unclamping.

Revolutions: 10 – 3000 rpm

Maximum Torque (150 rpm): 250 Nm

Tool: SK 50

Turning: 0 – 360

Coolant Trough Spindle: option 12 (bar)

Lubrication: oil

Can be used with long adapter.

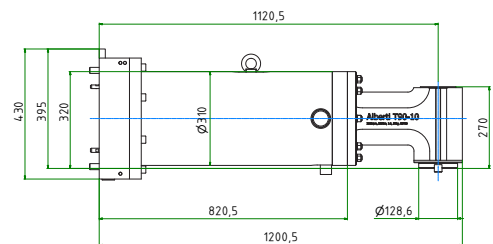

E-PHAmi

Automatically or manually attached to the headstock, automatic tool clamping and unclamping.

Revolutions: 12 – 15.000 rpm

Maximum Power: 40,5 kW (S1)

Maximum Torque: 128,9Nm (S1)

Tool: SK 40 / SK 50

Turning: +/- 95°

Outside Coolant: standard

For machines with spindle diameter 130 / 150 / 160 mm.

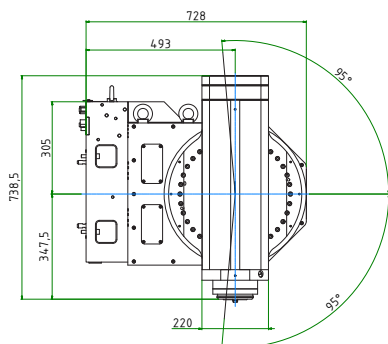
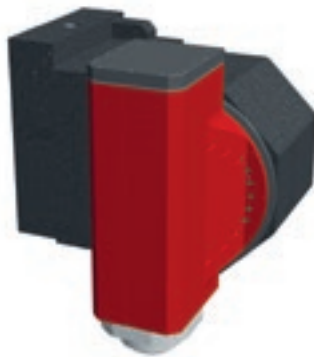

Facing Heads

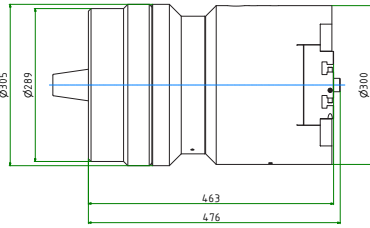

COGSDILL FACING HEAD ZX 200 / ZX 300

Plate Diameter: 200 / 420
 Positioning: automatic
 Max rpm: 800 / 500
 Approx. Weight: 93 / 154 kg
 Boring Accuracy: H7
 Radial Traverse: 107 / 168
 Maximum Boring Diameter: 380 / 650

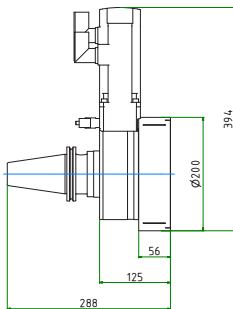

D'ANDREA FACING HEAD TA-T 200

Plate Diameter: 200
 Positioning: Automatic
 Max rpm: 1400
 Approx. Weight: 20,5 kg
 Boring Accuracy: H7
 Radial Traverse: ± 32,5
 Maximum Boring Diameter: 400
 (depth depending)

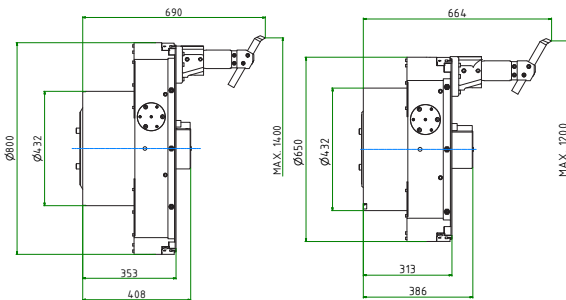

FERMAT FACING HEAD FH 65 / FH 80

Plate Diameter: 650 / 800
 Positioning: Automatic
 Max rpm: 250 / 220
 Approx. Weight: 290 / 360 kg
 Boring Accuracy: 0.05
 Radial Traverse: 170 / 220
 Maximum Boring Diameter: 1200 / 1400

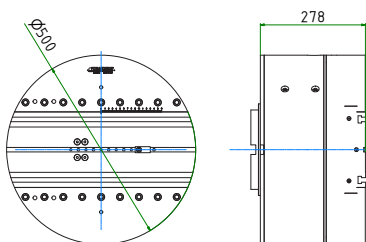

D'ANDREA FACING HEAD UT 5-500 S (UT 5-630, UT5-800)

Plate Diameter: 500 / 630 / 800
 Positioning: Automatic
 Max rpm: 200 / 250 / 315
 Approx. Weight: 230 / 310 / 530 kg
 Boring Accuracy: H7
 Radial Traverse: 160 / 200 / 250
 Maximum Boring Diameter: 1000 / 1250 / 1400 (depth depending)

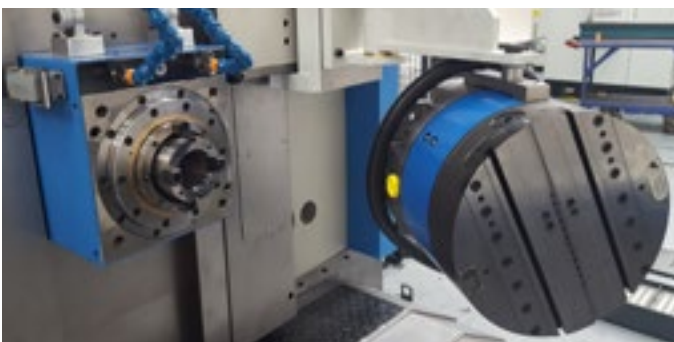

AUTOMATIC 2 POSITION PICK-UP



PICK-UP STATION FOR FLOOR TYPE MODELS



TABLE-SIDE HINGED HEAD HOLDER

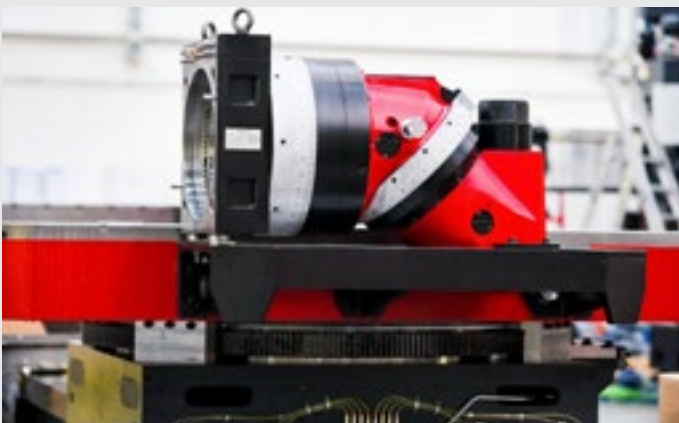

Pick-up station

Pick-up is used for automatic change of milling heads. All automatic milling heads have sensitive sensors, so it is dangerous to change heads manually as there is a big risk of damage.

There are different design solutions. Depending on the needs of production, the customer can choose what suits him best.

1 POSITION PICK-UP (ATTACHED TO ROTARY TABLE CLAMPING PLATE)

Suitable for table-type machines for tables **1800 x 2200 mm** and bigger.

- The head holder consists of two hinged arms permanently attached to the side of R plate (when arms are folded, there is no risk of holder hitting the column during rotation).
- The head is accurately seated in portable frame.
- For this solution, as an option, we offer also cover for the milling head, which prevents its possible damage (for example caused by flying chips during machining).
- It is semi-automatic exchange of milling head, controlled and inspected by machine operator.
- Fast and accurate exchange for reasonable price.

1 POSITION PICK-UP (ATTACHED TO FLOOR PLATE)

Suitable for machines types **WRF** and **WF 13R with floor plates**.

- The head holder is placed on floor plate, in locating sockets inside T-slots.
- Head is accurately seated on the holder on cylindrical pins.
- In some situations, the holder may take space necessary for workpiece (then it is to be removed out of work area by crane).
- It is semi-automatic exchange of milling head, controlled and inspected by machine operator.

2 POSITION PICK-UP (AUTOMATIC)

Suitable for **WFT 13** and **WFT 15** machines.

- Automatic Exchange with CNC Control System.
- The whole pick-up is movable, to it can reach the headstock.
- Typically, one position is for a milling head and the other for a cover plate.
- Can be also used for two milling heads (cover plate is made of plastic and is attached to headstock manually).
- Fast and accurate exchange that eliminates the danger of damaging the adapter of milling head.

2 / 3 / 4 - POSITION PICK-UP (FLOOR TYPE)

Suitable for all **floor type** machines.

- Attached to floor plate.
- Can be integrated into the area of robot for exchange of tools.
- Fast and accurate exchange that eliminates the danger of damaging the adapter of milling head.

ATC CHAIN TYPE



ATC CHAIN TYPE HAND



ROBOT TOOL CHANGER



ROBOT TOOL CHANGER INSIDE



Automatic Tool Changer ATC

AUTOMATIC TOOL CHANGING

Automatic tool change helps to save time, increase productivity and protect the operator. It is the choice for productive production.

ATC CHAIN TYPE

ATC is able to exchange tools directly into the spindle or into milling head in zero position. Two options for horizontal or horizontal and vertical exchange.

- Horizontal exchange only - into the boring spindle.
- Horizontal and vertical exchange - into the boring spindle and into automatic milling head in vertical or horizontal position.
- Hydraulically operated.
- Max. number of tools: 120.

ROBOT TOOL CHANGER

Robot is able to exchange tools virtually into any position of head, max. number of tools is 210. Tool rack with robot is an independent enclosed work space that provides possibility of manipulation with tools without safety risks for operator or risk of crash for the machine. There is a special access point for adding tools, from where robot takes tools and put them into tool rack. This mode increases time effectivity if the machine.

The advantages of the robotic solution:

- Faster tool change.
- Almost no maintenance or service interventions.
- The possibility to change tools into various accessories and attachments.
- There is no interference in the work area normally encountered by the required rail of the traditional mechanical tool changer.
- The tools can be exchanged either to working spindle or to a predefined position on automatic milling head, as a standard exchange is possible in two positions (A +0, C+0), (A +180, C+0), optionally any other position is possible.
- The exchange can be also done into working spindle with an attached spindle support sleeve from Ferma's production.
- The robot is equipped with a hydraulic tool gripper with two holders. The first tool holder is occupied with the prepared tool and the second tool holder will be taking the tool out from the spindle. After the tool change is completed the doors will close automatically and the robot will place the tool into the defined position of the tool storage rack.
- Max. number of positions: 105 / 210 tools.
- Maximal tool weight: 25 kg by using gripper no. 1 and 2, 50 kg by using only one gripper.

Heads Suitability & Usage

MACHINE TYPE	WFC 10	WFT 11	WFT 13	WFT 15	WRFT 130
UHM 20	•	•	•	•	•
PHM 20	•	•	•	•	•
OHM 20	•	•	•	•	•
OMG Manual heads	•	•	•	•	•
Alberti T90-10	•	•	•	•	•
UHM 30			•	•	•
PHM 37			•	•	•
PHA 37			•	•	•
UHAmi 30			•	•	•
UHA 2,5°			•	•	•
UHA SDHS			•	•	•
PHAmi 60					
PHA 1°			•	•	•
E-PHAmi			•	•	•
ZX 200			•	•	•
ZX 300			•	•	•
D'A TA Tronic 200	•	•	•	•	•
FH 65			•		•
FH 80				•	
D'A UT3-360	•	•	•		•
D'A UT5-500			•	•	•
D'A UT5-630			•	•	•
D'A UT5-800			•	•	•

MACHINE TYPE

WRFT 150/160

WF 13

WF 13R

WRF 130

WRF 150/160

WRF 2G

WRF O

Manual Heads

•	•	•	•	•	•	•
•	•	•	•	•	•	•
•	•	•	•	•	•	•
•	•	•	•	•	•	•
•	•	•	•	•	•	•
•	•	•	•	•	•	•
•	•	•	•	•	•	•
•	•	•	•	•	•	•

Automatic Heads

•	•	•	•	•	•	•
•	•	•	•	•	•	•
•	•	•	•	•	•	•
•	•	•	•	•	•	•
•				•	•	•
•	•	•	•	•	•	•
•	•	•	•	•	•	•

Faceplate

	•	•	•			
	•	•	•			
•	•	•	•	•	•	•
	•	•	•			
•				•	•	•
	•	•	•			
•	•	•	•	•	•	•
•	•	•	•	•	•	•
•	•	•	•	•	•	•

REFERENCES

WFT 13 CNC

TIGERCAT INDUSTRIES INC. | CANADA

Parameters: X = 3000 mm, Y = 3500 / 3000 mm,
Z = 1500 mm, W = 730 mm, Rotary Table 1600 x
1800 mm / 2000 x 24000 mm, CTS 20 bar, ATC 40



WFT 13 CNC

VANHOUTTE | BELGIUM

Parameters: X = 4000 mm, Y = 3500 mm, Z = 2500 mm,
W = 730 mm, Rotary Table 1800 x 2200 mm, CTS 30 bar,
ATC 40, Milling Heads OHM 20, UHAmi 30, Face plate FH
65 Robotic Tool Change, Pick up Station



WFT 13 CNC

HYMSA HYDRAULICA Y MECANICA, S.A.A DE C.V. | MEXICO

Parameters: X = 3000 / 3500 mm, Y = 2000 / 2500 mm,
Z = 1700 mm, W = 730 mm, Rotary Table 1800 x
2200 mm, ATC 40 (60)



WFT 13 CNC

PRECISION BORING COMPANY | USA

Parameters: X = 3500 mm, Y = 2000 mm,
Z = 1700 mm, W = 730 mm, Rotary Table 1800 x
2200 mm, CTS 20 bar, ATC 40



REFERENCES



2x WRF 160 HEAVY CNC

NORDMARK, MASKINFABRIK A/S | DENMARK

Parameters: X = 17000 mm, Y = 8000 mm, Z = 1500 mm, W = 1000 mm, Rotary Table 3000 x 4000 / 3000 x 3000 mm tilting, CTS 50 bar, ATC 105 Robotic, Milling Heads PHAmi 60, PHA 37, Automatic Pick up Station



WRF 130 DUO CNC

BELAZ | BELORUSSIA

Parameters: X = 2 x 10500 mm, Y = 2 x 2500mm, Z = 2 x 900mm, W = 2 x 730 mm, Rotary Table diam. 2000 mm, 2 x CTS 50 bar, 2 x ATC 40, 2 x Milling Head UHA 30



WFT 15 CNC

HYDREMA A/S | GERMANY

Parameters: X = 3000 mm, Y = 2000 mm, Z = 2400 mm, W = 730 mm, Rotary Table 1800 x 2200 mm, Speed Clam System, CTS 20 bar, ATC 60



WRF 130 CNC

HOPAX S.R.O | CZECHIA

Parameters: X = 12900 mm, Y = 3500 mm, Z = 900 mm, W = 730 mm, Turning Table diam. 2000 mm, CTS 40 bar, ATC 40, Milling Head UHM 30

REFERENCES

WFT 13 CNC

MONTING SK D.O.O. | SLOVENIA

Parameters: X = 3000 mm, Y = 2500 mm,
Z = 1500 mm, Rotary Table 1600 x 1800 mm,
CTS 20 bar



WFT 13 CNC

CMI HEAVY INDUSTRIES | CANADA

Parameters: X = 4000 mm, Y = 3000 mm,
Z = 1500 mm, W = 730 mm, Rotary Table 1800 x
2200 mm, CTS 20 bar, ATC 40



WRF 160 CNC

FAY IND. | BRAZIL

Parameters: X = 8600 mm, Y = 5000 mm, Z = 1200 mm,
W = 1000 mm, Rotary Table 3000 x 3000 mm,
CTS 50 bar, Milling Heads VGCI, FH 80, IFWV 1B



WFT 13R CNC

SENNEBOGEN MASCHINENFABRIK GMBH. | GERMANY

Parameters: X = 4000 mm, Y = 3000 mm, Z = 1500 mm,
W = 730 mm, Rotary Table 1800 x 2200 mm,
CTS 30 bar, ATC 60, Milling Heads UHAmi30



REFERENCES



WRF 160 CNC

STROJE A MECHANIZMY A.S. | SLOVAKIA

Parameters: X = 8000 mm, Y = 5000 mm,
Z = 1200 mm, W = 1000 mm, Rotary Table
250 x 3500 mm, CTS 50 bar, ATC 60, Milling Head
UHM 30



WFT 13R CNC

BRUHIN AND DIETHELM AG | SWITZERLAND

Parameters: X = 3000 mm, Y = 2000 mm,
Z = 3000 mm, W = 600 mm, Rotary Table 1600 x
1800 mm, CTS 50 bar, Robotic Tool Changer 180,
Milling Head UHA 30



WFT 13 CNC

VEEKAY ENGINEERING | INDIA

Parameters: X = 4000 mm, Y = 2500 mm,
Z = 1700 mm, W = 730 mm, Rotary Table 1600 x
1800 mm, ATC 32, Milling Head UHM 30, D'Andrea
UT 5-500



WRF 160 CNC

PROMINOX S.A. | MOROCCO

Parameters: X = 11700 mm, Y = 6000 mm,
Z = 1200 mm, W = 1000 mm, Rotary Table
2500 x 3000 mm, CTS 50 bar, ATC 60, Milling Head
UHM 30

REFERENCES

WFT 13 CNC

TIANJIN ZHONGZHONG SCIENCE & TECHNOLOGY CO.LTD. | CHINA

Parameters: X = 3000 mm, Y = 2000 mm, Z = 1700 / 1200 mm, W = 730 mm, Rotary Table 1800 x 2200 mm



WRF 130 CNC

FAURE PERE ET FILS | FRANCE

Parameters: X = 6200 mm, Y = 3000 mm, Z = 900 mm, W = 730 mm, Rotary Table 2000 x 2400 mm, CTS 20 bar, Milling Head UHM 30 with automatic clamping



WRF 160 HEAVY CNC

D & S MACHINE SERVICE INC. | USA

Parameters: X = 2700 mm, Y = 5000 mm, Z = 1500 mm, W = 1000 mm, Rotary Table 3500 x 3500 mm, CTS 20 bar, ATC 60, Milling Heads UHAmi 30, PHA 37



WFT 13 CNC

DOOSAN BOBCAT ENGINEERING s.r.o. | CZECHIA

Parameters: X = 5000 mm, Y = 2500 mm, Z = 2000 mm, W = 730 mm, Rotary Table 1800 x 2600 mm, CTS 20 bar, ATC 40



REFERENCES



WFT 11 CNC

FRANZ WÖLFER ELEKTROMASCHINEN-FABRIK OSNABRÜCK GMBH. | GERMANY

Parameters: X = 2000 mm, Y = 2000 mm, Z = 1250 mm, W = 730 mm, Rotary Table 1200 x 1400 mm, CTS 40 bar, ATC 40



WFT 13 CNC

RAVEN | SLOVAKIA

Parameters: X = 5000 mm, Y = 2500 mm, Z = 2000 mm, W = 730 mm, Table 1800 x 2600 mm, CTS 20, ATC 32, Milling Head PHM 20



WFT 11 CNC

MOJSTROVINA, D.O.O. | SLOVENIA

Parameters: X = 5000 mm, Y = 2000 mm, Z = 1700 mm, Rotary Table 1800 x 2600 mm, CTS 70 bar



WFT 15R CNC

ELZAM-ZAMECH SP. Z O.O. | POLAND

Parameters: X = 4000 mm, Y = 2500 mm, Z = 1500 mm, Rotary Table 2000 x 2400 mm, CTS 20 bar, ATC 40HV, UHAmi 0,001°

4x
FERMAT
MACHINES

REFERENCES

WFC 10 CNC

EMILE EGGER & CIE SA | SWITZERLAND

Parameters: X = 1250 mm, Y = 1700 mm,
Z = 1250 mm, Rotary table 1250 x 1400 mm,
CTS 70 bar, ATC 60, DAndrea UT 360S



WFC 10 CNC

ANJALANKOSKEN METALLINEN | FINLAND

Parameters: X = 2000 mm, Y = 1700 mm,
Z = 1250 mm, Rotary Table 1250 x 1800 mm,
CTS 70 bar, FERMAT Robotics 105, UHM 20



WFC 10 CNC

KROMET SP. Z O.O. | POLAND

Parameters: X = 2000 mm, Y = 1700 mm,
Z = 1250 mm, Rotary Table 1250 x 1400 mm,
CTS 70 bar



WFC 10HS CNC

RUPET FORMY A MODELY S.R.O. | CZECHIA

Parameters: X = 2000 mm, Y = 1700 mm,
Z = 1250 mm, Rotary Table 1250 x 1800 mm,
CTS 70 bar, ATC 40, 5500 rpm



REFERENCES



WFT 13 CNC

MABOTEC BV | NETHERLANDS

Parameters: X = 3000 mm, Y = 2000 mm,
Z = 2000 mm, Rotary Table 1400 x 1600 mm,
CTS 50 bar, FERMAT Robotics 105



4x
FERMAT
MACHINES

WFT 13R CNC

STT SERVIS S.R.O. | CZECHIA

Parameters: X = 5000 mm, Y = 2500 mm,
Z = 2000 mm, Rotary Table 2000 x 3000 mm,
CTS 20 bar, ATC 32H



2x
FERMAT
MACHINES

WRF 160 CNC

EAST METAL A/S | DENMARK

Parameters: X = 14800 mm, Y = 6000 mm,
Z = 1200 mm, Rotary Table 3000 x 3000 mm,
CTS 50 bar, UHAmi 0,001°, ATC 90



3x
FERMAT
MACHINES

WF 13R CNC

**BENDER & HESSE FRÄS- UND BOHR-
WERKTECHNIK GMBH | GERMANY**

Parameters: X = 9000 mm, Y = 3000 mm,
Z = 600 mm, Rotary Table 1800 x 2200 mm,
PHM 37 1°, ATC 40

NOTES

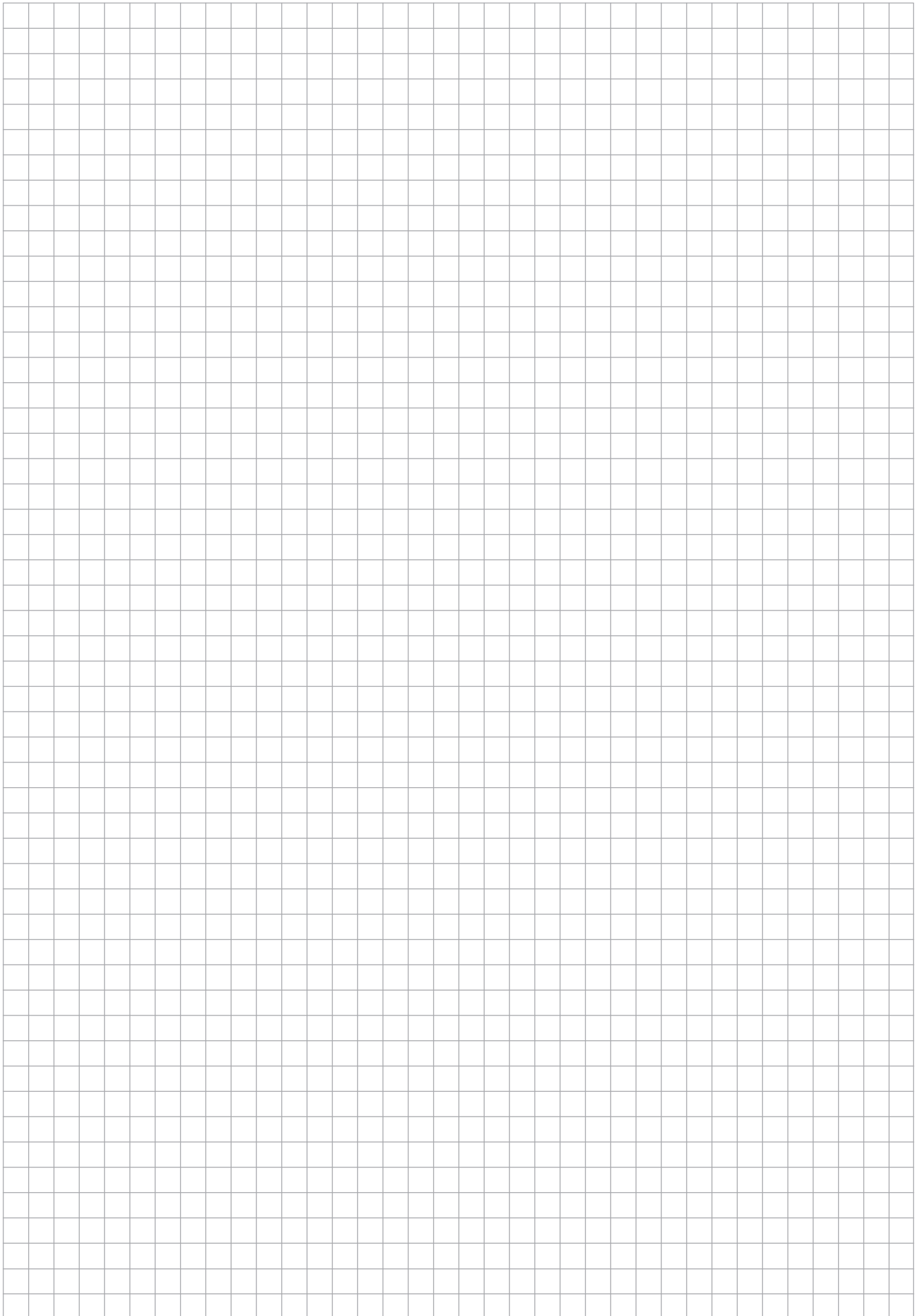

FERMAT



WFT 13 CNC

for RAVEN, a.s., Slovakia



Parameters: X = 5000 mm (196.85") | Y = 2500 mm (98.43") | Z = 2000 mm (78.74") | W = 730 mm (28.74") |
Rotary Table = 1800 x 2600 mm (70.87 x 102.36") | CTS 4+20 | ATC 32 | PHM 20

FERMAT



Visit our **You Tube** Channel
for videos of:

- Machines
- Accessories
- Applications
- Cutting tests
- References

youtube.com/fermatexport

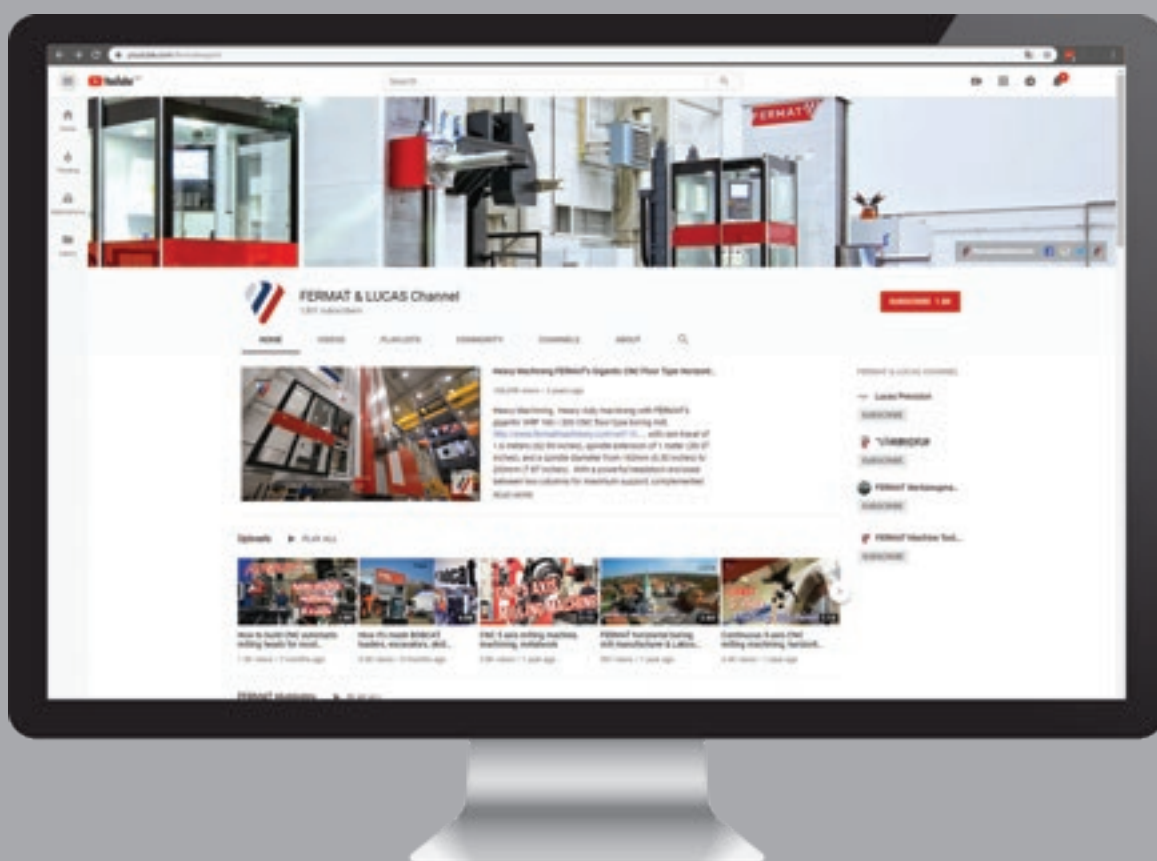

FERMAT Group, a.s.

Prumyslova 11, 102 00 Prague 10

Czech Republic

Phone: +420 774 339 356

E-mail: export@fermatmachinery.com

www.fermatmachinery.com